

01 - 03.1

04.11.GB

**LDM valves with
Siemens actuators (Landis & Staefa)**



Kv coefficient calculation

Calculation itself is carried out with respect to conditions of regulating circuit and operating medium according to equations mentioned below. Control valve must be designed to be able to regulate maximal flow quantity at given operating conditions. At the same time it is necessary to check whether minimal flow quantity can be even regulated or not.

Condition is the following ratio $r > Kvs / Kv_{min}$

Because of eventual minus tolerance 10% of Kv_{100} against Kvs and requirement for possible regulation within range of maximal flow (decrement and increase of flow), producer recommends to select Kvs value higher than maximal operating Kv value:

$$Kvs = 1.1 \cdot 1.3 \cdot Kv$$

It is necessary to take into account to which extent Q_{max} involve "precautionary additions" that could result in valve oversizing.

Relations of Kv calculation

		Pressure drop $p_2 > p_1/2$ $\rho p < p_1/2$	Pressure drop $\rho p \geq p_1/2$ $p_2 \leq p_1/2$
Kv =	Liquid	$\frac{Q}{100} \sqrt{\frac{\rho_1}{\rho p}}$	$\frac{Q}{100} \sqrt{\frac{\rho_1}{\rho p}}$
	Gas	$\frac{Q_n}{5141} \sqrt{\frac{T_n}{\rho p \cdot p_2}}$	$\frac{2 \cdot Q_n}{5141 \cdot p_1} \sqrt{\frac{T_n}{\rho p}}$
	Superh. steam	$\frac{Q_m}{100} \sqrt{\frac{v_2}{\rho p}}$	$\frac{Q_m}{100} \sqrt{\frac{2v}{p_1}}$
	Sat. steam	$\frac{Q_m}{100} \sqrt{\frac{v_2 \cdot x}{\rho p}}$	$\frac{Q_m}{100} \sqrt{\frac{2v \cdot x}{p_1}}$

Above critical flow of vapours and gases

When pressure ratio is above critical ($p_2/p_1 < 0.54$), speed of flow reaches acoustic velocity at the narrowest section. This event can cause higher level of noisiness. Then it is convenient to use a throttling system ensuring low noisiness (multi-step pressure reduction, damping orifice plate at outlet).

Dimensions and units

Marking	Unit	Name of dimension
Kv	$m^3 \cdot h^{-1}$	Flow coefficient under condition of units of flow
Kv_{100}	$m^3 \cdot h^{-1}$	Flow coefficient at nominal stroke
Kv_{min}	$m^3 \cdot h^{-1}$	Flow coefficient at minimal flow rate
Kvs	$m^3 \cdot h^{-1}$	Valve nominal flow coefficient
Q	$m^3 \cdot h^{-1}$	Flow rate in operating conditions (T_1, p_1)
Q_n	$Nm^3 \cdot h^{-1}$	Flow rate in normal conditions (0°C, 0.101 Mpa)
Q_m	$kg \cdot h^{-1}$	Flow rate in operating conditions (T_1, p_1)
p_1	MPa	Upstream absolute pressure
p_2	MPa	Downstream absolute pressure
p_s	MPa	Absolute pressure of saturated steam at given temperature (T_1)
ρp	MPa	Valve differential pressure ($\rho p = p_1 - p_2$)
ρ_1	$kg \cdot m^{-3}$	Process medium density in operating conditions (T_1, p_1)
ρ_n	$kg \cdot Nm^{-3}$	Gas density in normal conditions (0°C, 0.101 Mpa)
v_2	$m^3 \cdot kg^{-1}$	Specific volume of steam when temperature T_1 and pressure p_2
v	$m^3 \cdot kg^{-1}$	Specific volume of steam when temperature T_1 and pressure $p_1/2$
T_1	K	Absolute temperature at valve inlet ($T_1 = 273 + t_1$)
x	1	Proportionate weight volume of saturated steam in wet steam
r	1	Rangeability

Flow characteristic selection in regard of valve stroke

To make right selection of valve flow characteristic, it is suitable to carry out checking of what stroke values will be reached in different operation states. We recommend to carry out such checking at least for minimal, nominal and maximal flow rates. The principle for flow characteristic selection is to avoid, if possible, 5%–10% of the beginning and end of the valve stroke range.

To calculate valve stroke at different operating conditions with different types of flow characteristics is possible with the advantage of using LDM's calculation programme VALVES. The programme serves for complete design of valve from Kv calculation to specification of a concrete valve with its actuator.

Valve flow characteristics

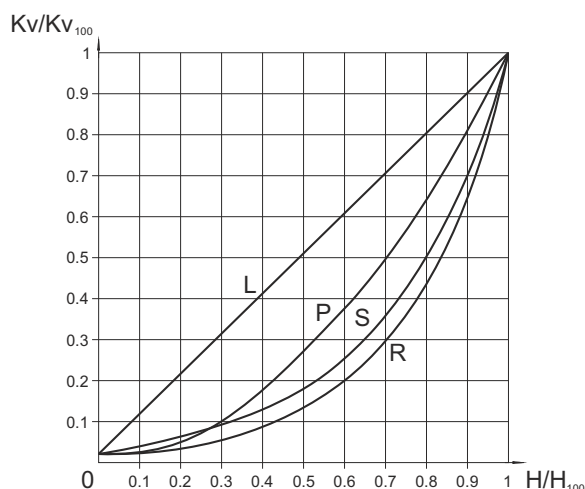

L - linear characteristic

$$Kv/Kv_{100} = 0.0183 + 0.9817 \cdot (H/H_{100})$$

R - equal-percentage characteristic (4-percentage)

$$Kv/Kv_{100} = 0.0183 \cdot e^{(4 \cdot H/H_{100})}$$

P - parabolic characteristic

$$Kv/Kv_{100} = 0.0183 + 0.9817 \cdot (H/H_{100})^2$$

S - LDM spline® characteristic

$$Kv/Kv_{100} = 0.0183 + 0.269 \cdot (H/H_{100}) - 0.380 \cdot (H/H_{100})^2 + 1.096 \cdot (H/H_{100})^3 - 0.194 \cdot (H/H_{100})^4 - 0.265 \cdot (H/H_{100})^5 + 0.443 \cdot (H/H_{100})^6$$

Principles for plug type selection

V-ported plugs should not be used in above - critical differential pressures with inlet pressure $p_i \geq 0,4$ MPa and for regulation of saturated steam. In these cases we recommend to use a perforated plug. The perforated plug should be also used always when cavitation may occur due to a high differential pressure value or valve ports erosion caused by high speed of process medium flow. If the parabolic plug is used (because of small Kvs) for pressures $p_i \geq 1,6$ MPa and above - critical differential pressures, it is necessary to close both plug and seat with a hard metal overlay, i.e. stellite trim.

Packing - O -ring EPDM

Packing is designed for non-aggressive media with temperature from 0° to 140 °C. Packing excels with its reliability and long time tightness. It has ability of sealing even if the valve stem is a bit damaged. Low frictional forces enables valve to be actuated with a low-linear-force actuator. Service life of sealing rings depends on operating conditions and it is more than 400 000 cycles on average.

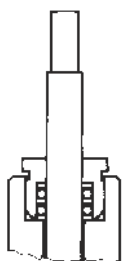

Applied to RV 102, RV 103

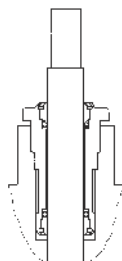

Applied to RV 2xx

Packing - DRSpack® (PTFE)

DRSpack® (Direct Radial Sealing Pack) is a packing with high tightness at both low and high operating pressure values.

It is the most used type of packing suitable for temperatures ranging from 0° to 260°C. The pH range is from 0 to 14. The packing enables using of actuators with low linear force. The design enables an easy change of the whole packing. The average service life of DRSpack® is more than 500 000 cycles.

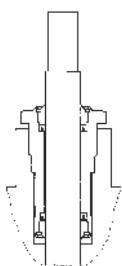

Service life of bellows packing

Bellows material	Temperature				
	200°C	300°C	400°C	500°C	550°C
1.4541	100 000	40 000	28 000	7 000	not applicable
1.4571	90 000	34 000	22 000	13 000	8 000

Values specified in the table above show minimal guaranteed number of cycles with the valve full stroke when the bellows is fully lengthened and pressed. In regulation, when the valve

Packing - Bellows

Bellows packing is suitable for low and high temperatures ranging from -50° to 550° C. Bellows ensures absolute tightness to environment. Packing is equipped with safety PTFE packing as standard to prevent medium from leaking in case of damage to bellows. Intensive linear forces are not required.

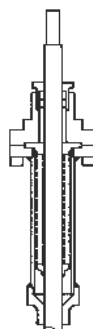

Application of bellows packing

Bellows packing is suitable for applications with very aggressive, toxic or other dangerous media that require absolute tightness to environment. In such case, it is necessary to check compatibility of used body material as well as the valve inner parts material with process medium. It is recommended to use bellows with safety packing preventing medium from leaking in case of damage to bellows when there is an extremely dangerous process medium used.

Bellows is also a great solution to use of process medium either with temperature below zero when ice accretions cause premature damage to packing or with high temperatures when bellows ensures medium cooling.

Rangeability

Rangeability is the ratio of the biggest value of flow coefficient to the smallest value. In fact it is the ratio (under the same conditions) of highest regulated flow rate value to its lowest value. The lowest or minimal regulated flow rate is always higher than 0.

moves only in a portion of the stroke range at the inner centre of the valve, the service life of the bellows is many times longer then depending on concrete operating conditions.

Procedure for designing of two-way valve

Given: medium water, 155 °C, static pressure at piping spot 1000 kPa (10 bar), $\rho p_{DISP} = 80$ kPa (0,8 bar), $\rho p_{PIPELINE} = 15$ kPa (0,15 bar), $\rho p_{APPLIANCE} = 25$ kPa (0,25 bar), nominal flow rate $Q_{NOM} = 8$ m³.h⁻¹, minimal flow rate $Q_{MIN} = 1,3$ m³.h⁻¹.

$$\rho p_{VALVE} = \rho p_{DISP} + \rho p_{APPLIANCE} + \rho p_{PIPELINE} - \rho p_{DISP} = 80 - 25 - 15 = 40 \text{ kPa (0,4 bar)}$$

$$Kv = \frac{Q_{NOM}}{\sqrt{\rho p_{VALVE}}} = \frac{8}{\sqrt{0,4}} = 12,7 \text{ m}^3 \cdot \text{h}^{-1}$$

Precautionary additions for process tolerances (provided that flow rate Q was not oversized):

$$Kvs = (1,1 \text{ to } 1,3) \cdot Kv = (1,1 \text{ to } 1,3) \cdot 12,7 = 14 \text{ to } 16,5 \text{ m}^3 \cdot \text{h}^{-1}$$

Now we choose the nearest Kvs value from those available in our catalogue, i.e. $Kvs = 16$ m³.h⁻¹. This value corresponds to nominal size of DN 32. Then if we choose flanged execution PN 16, body made of spheroidal cast iron, with metal - PTFE seat sealing, packing PTFE and equal-percentage flow characteristic, we will get the following specification No.:

RV 21x XXX 1423 R1 16/220-32

x in the valve code above (21x) stands for valve execution (direct or reverse) and depends on type of used actuator which should be chosen in respect to demands of regulating system (type, producer, voltage, type of control, necessary torque or linear force, etc.)

Determination of real pressure drop value of a chosen valve at fully open

$$\rho p_{VENTIL H100} = \left(\frac{Q_{NOM}}{Kvs} \right)^2 = \left(\frac{8}{16} \right)^2 = 0,25 \text{ bar (25 kPa)}$$

The control valve's real pressure drop calculated this way shall be taken into account in a hydraulic calculation of regulating circuit.

Determination of valve's real authority

$$a = \frac{\rho p_{VALVEH100}}{\rho p_{VALVEH0}} = \frac{25}{80} = 0,31$$

Value a should be at least equal to 0,3. A chosen valve checking is then satisfactory.

Caution: the valve's authority calculation should be related to a valve pressure difference in its closed position i.e. disposition pressure value in a branch ρp_{AVAIL} when flow rate is zero, not to a pressure value of a pump ρp_{PUMP} , because, due to pipeline circuit pressure drops up to the spot where the regulating branch is connected, the following equation applies: $\rho p_{AVAIL} < \rho p_{PUMP}$. In such cases we consider for simplicity the following: $\rho p_{AVAIL H100} = \rho p_{AVAIL H0} = \rho p_{DISP}$.

Checking of rangeability

We carry out the same checking for minimal flow rate $Q_{MIN} = 1,3$ m³.h⁻¹. The following differential pressure values correspond to the min. flow rate: $\rho p_{APPLIAN. QMIN} = 0,40$ kPa, $\rho p_{VALVE QMIN} = 80 - 0,4 - 0,66 = 78,94 = 79$ kPa.

$$Kv_{MIN} = \frac{Q_{MIN}}{\sqrt{\rho p_{VALVE QMIN}}} = \frac{1,3}{\sqrt{0,79}} = 1,46 \text{ m}^3 \cdot \text{h}^{-1}$$

Necessary rangeability value

$$r = \frac{Kvs}{Kv_{MIN}} = \frac{16}{1,46} = 11$$

shall be lower than mentioned rangeability value of $r = 50$. Checking is then satisfactory.

Selection of suitable flow characteristic

On the basis of calculated values Kv_{NOM} and Kv_{MIN} , it is possible to read the appropriate stroke values from the graph for individual types of flow characteristics of the valve and choose the most suitable one accordingly. Here we have $h_{NOM} = 95\%$, $h_{MIN} = 29\%$ for equal-percentage characteristic. In that case, LDMspline® flow characteristic is more suitable (94% and 17% of the stroke). It corresponds to the following specification code :

RV 21x XXX 1423 S1 16/220-32

Scheme of typical regulation loop with the application of two-way control valve

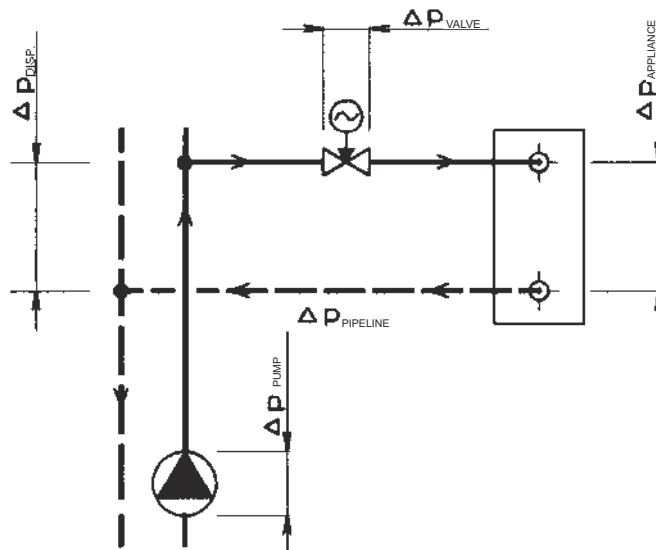

Remark: More detailed information on calculation and design of LDM control valves is mentioned in calculation instructions No. 01-12.0. Equations mentioned above apply in a simplified way to water. To reach optimum results, we recommend to use original calculation programme VALVES which is available on request free of charge.

Procedure for designing of three- way valve

Given: medium water, 90 °C, static pressure at piping spot 1000 kPa(10 bar), $\rho p_{PUMP2} = 40$ kPa (0,4 bar), $\rho p_{PIPELINE} = 10$ kPa (0,1bar), $\rho p_{APPLIANCE} = 20$ kPa (0,2 bar), flow rate $Q_{NOM} = 7$ m³.h⁻¹

$$\rho p_{PUMP2} = \rho p_{VALVE} + \rho p_{APPLIANCE} + \rho p_{PIPELINE}$$

$$\rho p_{VALVE} = \rho p_{PUMP2} - \rho p_{APPLIANCE} - \rho p_{PIPELINE} = 40 - 20 - 10 = 10 \text{ kPa (0,1bar)}$$

$$Kv = \frac{Q_{NOM}}{\sqrt{\rho p_{VALVE}}} = \frac{7}{\sqrt{0,1}} = 22,1 \text{ m}^3 \cdot \text{h}^{-1}$$

Precautionary additions for process tolerances (provided that flow rate Q was not oversized):

$$Kvs = (1,1 \text{ to } 1,3) \cdot Kv = (1,1 \text{ to } 1,3) \cdot 22,1 = 24,3 \text{ to } 28,7 \text{ m}^3 \cdot \text{h}^{-1}$$

Now we choose the nearest Kvs value from those available in our catalogue, i.e. $Kvs = 25$ m³.h⁻¹. This value corresponds to nominal size of DN 40. Then if we choose flanged execution PN 16, body made of spheroidal cast iron, with metal - PTFE seat sealing, packing PTFE and equal-percentage flow characteristic, we will get the following specification No.:

RV 21x XXX 1413 L1 16/140-32

x in the valve code above (21x) stands for valve execution (direct or reverse) and depends on type of used actuator which should be chosen in respect to demands of regulating system (type, producer, voltage, type of control, necessary torque or linear force, etc.)

Determination of real pressure drop value of a chosen valve at fully open

$$\rho p_{VALVE H100} = \left(\frac{Q_{NOM}}{Kvs} \right)^2 = \left(\frac{7}{25} \right)^2 = 0,08 \text{ bar (8 kPa)}$$

The control valve's real pressure drop calculated this way shall be taken into account in a hydraulic calculation of regulating circuit.

Caution: To ensure reliable function of three-way valves, the most important condition is to keep minimum available pressure difference between A and B ports. Three-way valves are capable to manage even high pressure difference between A and B ports but valve's flow characteristic deformats then and so regulation properties deteriorate. So if in doubt about pressure difference value between those two ports (e.g. when three-way valve is piped directly into primary side without pressure separation), we recommend to use a two-way valve in combination with a primary-secondary side short cut to ensure a reliable regulation. The authority of A-AB way of three-way valve is, providing a constant flow rate in appliance circuit, the following:

$$a = \frac{\rho p_{VALVE H100}}{\rho p_{VALVE H0}} = \frac{8}{8} = 1$$

which means that the behaviour of flow in A-AB way corresponds to ideal flow curve of the valve. In that case there are Kvs values in both ports the same with linear characteristic i.e. the total flow is nearly constant.

A combination of equal-percentage characteristic in A port and linear characteristic in B port shall be selected in those cases when loading of A port with differential pressure against B port cannot be avoided or when the primary side parametres are too high.

Scheme of a typical regulation loop with the application of a three-way mixing control valve

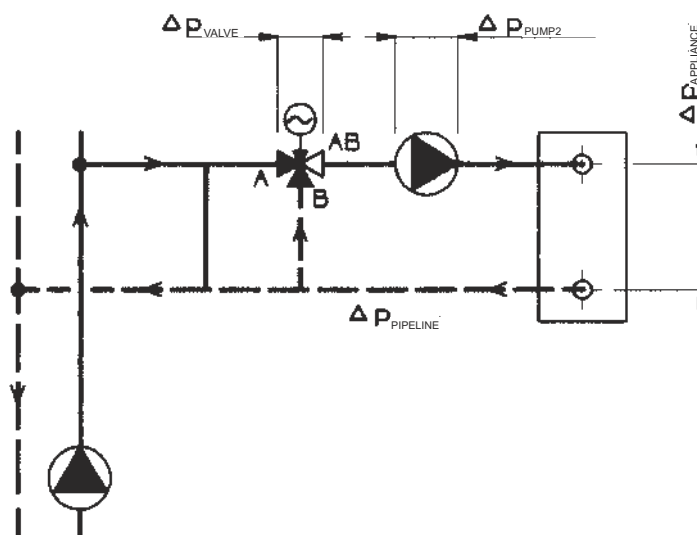

Remark: More detailed information on calculation and design of LDM control valves is mentioned in calculation instructions No. 01-12.0. Equations mentioned above apply in a simplified way to water. To reach optimum results, we recommend to use original calculation programme VALVES which is available on request free of charge.

RV 102 L RV 103 L



Control valves DN 15 - 50, PN 16 with Siemens actuators (Landis & Staefa)

Description

Control valves series RV 102 are two-way or three-way valves with internal threaded connection. Valve body is made of brass. Control valves series RV 103 are two-way or three-way valves with flanged connection. Valve body is made of grey cast iron. Valves are optionally manufactured in the following executions:

- three-way control valve
- two-way, reverse, control valve
- two-way, angular, control valve

Valves RV 102 L and RV 103 L are especially designed for electric or electrohydraulic actuators of producer Siemens (Landis & Staefa).

Application

Valves are designed for application in heating, ventilation or air conditioning systems for maximal temperature 140 °C.

The maximal operating pressures in behaviour with a chosen material and process medium temperature are mentioned on page 33 of this catalogue.

Process media

Valve series RV 102 and RV 103 are designed to regulate the flow and pressure of liquids, gases and vapours without abrasive particles e.g. water, low-pressure steam (it applies to RV 102 only), air and other media compatible with material of the valve inner parts. Medium acidity and alkalinity should not exceed range of pH 4.5 to 9.5.

To ensure reliable regulation, producer recommends to pipe a strainer in front of the valve into pipeline.

The valve cannot work in cavitation conditions. RV 103 valves are not suitable for steam and steam condensate.

Installation

The valve is to be piped the way so that the direction of medium flow will coincide with the arrows on the body (inlet ports A, B and outlet port AB).

In flow-diverting valves, the process medium flow is reversed (inlet port AB and outlet ports A, B).

Valve can be installed in any position except position when the actuator is under the valve body.

Technical data

Series	RV 102	RV 103
Type of valve	Three-way control valve Two-way, reverse control valve	
Nominal size range	DN 15 - 50	
Nominal pressure	PN 16	
Body material	Brass 42 3135	Grey cast iron EN-JL 1040
Plug material	Brass 42 3234	
Operating temperature range	-5 to 140 °C	
Face to face dimensions	Line M4 acc. to DIN 3202 (4/1982)	Line 1 acc. to ČSN-EN 558-1 (3/1997)
Connection	Internal threaded coupling Acc. to ČSN-EN ISO 228-1 (9/2003)	Flange type B1 (raised faces) Acc. to ČSN-EN 1092-1 (4/2002)
Type of plug	V-ported plug	
Flow characteristic	Linear; equal-percentage (applicable to basic Kvs values)	
Kvs values	0.6 to 40 m ³ /hour	
Leakage rate	Class III. acc. to ČSN-EN 1349 (5/2001) (<0.1 % of Kvs) in A-AB way	
Rangeability r	50 : 1	
Packing	O - ring EPDM	

Note

The actuator nominal stroke value is not equal to the valve nominal stroke value. When used resistance position transmitter, it is necessary to take into account that range of resistance signal will be reduced to 500-1000 Ω at nominal stroke of 10 mm and to 200-1000 Ω at nominal stroke of 16 mm.

Range of direct control is reduced the same way with actuators controlled with continuous signal, i.e. to 5-10V (12 - 20 mA) at valves with stroke of 10 mm and to 2-10V (8 - 20 mA) at valves with stroke of 16 mm.

The actuators 6xxx equipped with calibration function enables the actuator's control in the full range.

Kvs values and differential pressures

ρp_{max} value is the valve maximal differential pressure when reliable opening and closing can be guaranteed. Because of seat and plug service life, it is recommended so that

permanent differential pressure would not exceed 0.6 MPa for valves RV 102 and 0.4 MPa for valves RV 103.

For further information on actuating, see actuators' catalogue sheets		Actuating (actuator)					SQX ...	SAX ...	SKD ...
		Marking in valve specification No.					ELA, ELB	ELE	HLA, HLB, HLC
		Linear force					700 N	800 N	1000 N
		Kvs [m ³ /hour]					Δp_{max}	Δp_{max}	Δp_{max}
DN	H	1	2	3	4	5	MPa	MPa	MPa
15	10	4.0	2.5	1.6	1.0	0.6	1.60	1.60	1.60
20		6.3	4.0	2.5	---	---	1.57	1.60	1.60
25		10.0	6.3	4.0	---	---	1.02	1.18	1.51
32	16	16.0	10.0	6.3	---	---	0.63	0.73	0.94
40		25.0	16.0	10.0	---	---	0.40	0.47	0.61
50		40.0	25.0	16.0	---	---	0.24	0.28	0.36

Dimensions and weights for the type RV 102

DN	C	L ₁	L ₂	L ₃	V ₁	V ₂	S	H	D	m
		mm	mm	mm	mm	mm	mm	mm	mm	kg
15	G 1/2	85	9	12	43	25	27	10	8	0.55
20	G 3/4	95	11	14	48	25	32			0.65
25	G 1	105	12	16	53	25	41			0.80
32	G 1 1/4	120	14	18	66	35	50	16	8	1.40
40	G 1 1/2	130	16	20	70	35	58			2.00
50	G 2	150	18	22	80	42	70			2.95

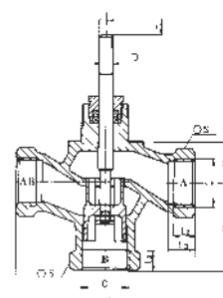

Dimensions and weights for the type RV 103

DN	D ₁	D ₂	D ₃	n x d	a	f	L ₁	V ₁	V ₂	H	D	m
	mm	mm	mm	mm	mm	mm	mm	mm	mm	mm	mm	kg
15	95	65	45	4x14	16	2	130	65	25	10	8	3.2
20	105	75	58				150	75	25			4.3
25	115	85	68				160	80	25			5.5
32	140	100	78	4x18	18	3	180	90	35	16	8	7.7
40	150	110	88				200	100	35			8.5
50	165	125	102				230	115	42			11.9

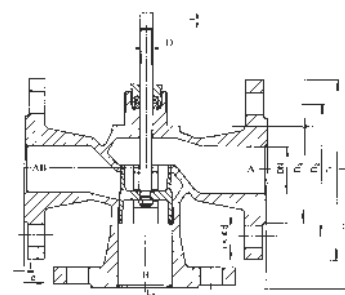

Valve complete specification No. for ordering

		XX	X X X	X X X	X X	X X	- XX /	XXX	- XX
1. Type of valve	Control valve	RV							
2. Series	Valves made of brass		1 0 2						
	Valves made of grey cast iron		1 0 3						
3. Actuating	Electric actuator			E					
	Electrohydraulic actuator			H					
	El. actuators SQX 32.00, SQX 32.03, SQX 82.00, SQX 82.03			E L A					
	El. actuators SQX 62			E L B					
	El. actuators SAX 31, SAX 61, SAX 81			E L E					
	EH actuators SKD 32.50, SKD 82.50, SKD 82.8, SKD 82.9			H L A					
	EH actuators SKD 32.51, SKD 32.21, SKD 82.51 *)			H L B					
	EH actuators SKD 62, SKD 62U *)			H L C					
4. Design	Straight, two-way, threaded valves				1				
	Angle, two-way, threaded valves	Applicable to RV 102			2				
	Mixing (diverting), three-way, threaded valves				3				
	Straight, two-way, flanged valves				4				
	Angle, two-way, flanged valves	Applicable to RV 103			5				
	Mixing (diverting), three-way, flanged valves				6				
5. Body material	Grey cast iron				3				
	Brass				5				
6. Flow characteristic	Linear				1				
	Equal-percentage ¹⁾				2				
7. Nominal Kvs value	Column No. acc. to Kvs values table				X				
8. Nominal pressure PN	PN 16						16		
9. Max. operating temperature °C								140	
10. Nominal size	DN								XX

Ordering example : Three-way control valves DN 25, PN 16 with electric actuator SQX 32.00, body material: brass, connection: internal thread G 1, linear flow characteristic, Kvs = 10 m³/hour is specified as follows: **RV102 ELA 3511 16/140-25**



Control valves and Fail-safe action valves DN 15 - 150, PN 16 and 40 with Siemens actuators (Landis & Staefa)

Description

Control valves RV 211, RV 221 and RV 231 (further in text RV 2x1) are single-seated valves designed for regulation and shut-off of process medium flow. In regard of used actuators, the valves are suitable for regulation at lower differential pressures. Flow characteristics, Kvs values and leakage rates correspond to international standards.

Valves with a fail-safe action HU 2x1 have the same design as RV 2x1 with addition of increased seat sealing. Valves are equipped with fail-safe action actuators (valve closes upon power failure).

Valves RV (HU) 2x1 L are especially designed for Siemens actuators (Landis & Staefa).

Application

These valves have a wide range of application in heating, ventilation, power generation and chemical processing industries. Valve body can be optionally made of spheroidal cast iron, cast steel and austenitic stainless steel according to operating conditions.

The materials selected correspond to the recommendation of ČSN-EN 1503-1 (1/2002) (steels) and ČSN-EN 1503-3 (1/2002) (cast). The maximal operating pressures in behaviour with a chosen material and process medium temperature are mentioned in the table on page 33 of this catalogue.

Process media

Valves series RV / HU 2x1 are designed for regulation (RV 2x1) and for regulation and shut-off (HU 2x1) of flow and pressure of liquids, gases and vapours without abrasive particles e.g. Water, steam, air and other media compatible with material of the valve inner parts. The application of valves made of spheroidal cast iron (RV 211) for steam is limited by the following parameters: Steam must be superheated (its dryness $x_s \geq 0,98$) and inlet pressure $p_1 \leq 0,4$ MPa when differential pressure is above-critical or $p_1 \leq 1,6$ MPa when differential pressure is under-critical. In case these values are exceeded, it is necessary to use valve made of cast steel (RV 221). To ensure reliable regulation, producer recommends to pipe a strainer in front of the valve or ensure in any other way that medium will not contain abrasive particles or impurities.

Installation

The valve is to be piped the way so that the direction of medium flow will coincide with the arrows on the body.

The valve can be installed in any position except position when the actuator is under the valve body. When medium temperature exceeds 150°C, it is necessary to protect the actuator against glowing heat from the pipeline e.g. by the means of proper insulating of the pipeline and valve or by tilting the valve away from the heat radiation.

Detailed informations for installation are included in „Instructions for installation and service“ manual.

Technical data

Series	RV / HU 211	RV / HU 221	RV / HU 231
Type of valve	Two-way, single-seated, reverse, control valve		
Nominal size range	DN 15 to 150		
Nominal pressure	PN 16, PN 40		
Body material	Spheroidal cast iron EN-JS 1025 (EN-GJS-400-10-LT)	Cast steel 1.0619 (GP240GH) 1.7357 (G17CrMo5-5)	Stainless steel 1.4581 (GX5CrNiMoNb19-11-2)
Seat material : DN 15 - 50	1.4028 / 17 023.6	1.4028 / 17 023.6	1.4571 / 17 347.4
DIN W.Nr./ČSN DN 65 - 150	1.4027 / 42 2906.5	1.4027 / 42 2906.5	1.4581 / 42 2941.4
Plug material : DN 15 - 65	1.4021 / 17 027.6	1.4021 / 17 027.6	1.4571 / 17 347.4
DIN W.Nr./ČSN DN 80 - 150	1.4027 / 42 2906.5	1.4027 / 42 2906.5	1.4581 / 42 2941.4
Operating temperature range	-20 to 300°C	-20 to 300°C	-20 to 300°C
Face to face dimensions	Line 1 acc. to ČSN-EN 558-1 (3/1997)		
Connection flanges	Acc. to ČSN-EN 1092-1 (4/2002)		
Flange faces	Type B1 (raised-faced) acc. to ČSN-EN 1092-1 (1/1999)	Type B1 (raised-faced) or Type F (female) or Type D (groove) acc. to ČSN-EN 1092-1 (2/2003)	
Type of plug	V-ported, parabolic, perforated		
Flow characteristic	Linear, equal-percentage, LDMspline®, parabolic		
Kvs value	0.4 to 360 m ³ /hour		
Leakage rate	Class III. acc. to ČSN-EN 1349 (5/2001) (<0.1% Kvs) for c. valves with metal-metal seat sealing Class IV. acc. to ČSN-EN 1349 (5/2001) (<0.01% Kvs) for c. valves with metal-PTFE seat sealing		
Rangeability r	50 : 1		
Packing	O - ring EPDM t _{max} =140°C, DRSpack® (PTFE) t _{max} =260°C, Bellows t _{max} =300°C		

Kvs values and differential pressures

Δp_{max} value is the valve max. differential pressure when open-close function is always guaranteed. In regard of service life of seat and plug, it is recommended so that

differential pressure would not exceed 1.6 MPa. Otherwise it is suitable to use perforated plug or sealing surfaces of seat and plug with a hard metal overlay.

For further information on actuating, see catalogue sheets		Actuating (actuator)						SQX ...		SAX ...		SKD ...		SKB ...		SKC ...	
		Marking in valve spec. No.						ELA, ELB		ELE		HLA, HLB, HLC		HLD, HLE, HLF		HLG, HLH, HLI	
		Linear force						700 N		800 N		1000 N		2800 N		2800 N	
		Kvs [m ³ /h]						Δp_{max}		Δp_{max}		Δp_{max}		Δp_{max}		Δp_{max}	
DN	H	1	2	3	4	5	6	metal	PTFE	metal	PTFE	metal	PTFE	metal	PTFE	metal	PTFE
15		---	2.5 ¹⁾	1.6 ¹⁾	1.0 ¹⁾	0.6 ¹⁾	0.4 ¹⁾	4.00	---	4.00	---	4.00	---	4.00	---	---	---
15		4.0 ¹⁾	---	---	---	---	---	2.82	---	3.40	---	4.00	---	4.00	---	---	---
20		---	---	2.5 ¹⁾	1.6 ¹⁾	1.0 ¹⁾	0.6 ¹⁾	4.00	---	4.00	---	4.00	---	4.00	---	---	---
20		---	4.0 ¹⁾	---	---	---	---	2.82	---	3.40	---	4.00	---	4.00	---	---	---
20		6.3 ¹⁾	---	---	---	---	---	1.27	---	1.56	---	2.15	---	4.00	---	---	---
25	20	---	---	---	2.5 ¹⁾	1.6 ¹⁾	1.0 ¹⁾	4.00	---	4.00	---	4.00	---	4.00	---	---	---
25		10.0	6.3 ²⁾	4.0 ²⁾	---	---	---	0.69	1.11	0.88	1.29	1.24	1.65	4.00	4.00	---	---
32		---	---	---	4.0 ¹⁾	---	---	2.82	---	3.40	---	4.00	---	4.00	---	---	---
32		16.0	10.0	6.3 ²⁾	---	---	---	0.34	0.66	0.45	0.77	0.67	0.99	2.66	2.98	---	---
40		25.0	16.0	10.0	---	---	---	0.16	0.42	0.23	0.49	0.38	0.63	1.66	1.91	---	---
50		40.0	25.0	16.0	---	---	---	0.06	0.25	0.10	0.29	0.18	0.37	0.95	1.14	---	---
65		63.0	40.0	25.0	---	---	---	---	0.15	0.02	0.17	0.07	0.22	0.54	0.69	---	---
80		100.0	63.0	40.0	---	---	---	---	---	---	---	---	---	---	---	0.34	0.47
100	40	160.0	100.0	63.0	---	---	---	---	---	---	---	---	---	---	---	0.20	0.30
125		250.0	160.0	100.0	---	---	---	---	---	---	---	---	---	---	---	0.11	0.19
150		360.0	250.0	160.0	---	---	---	---	---	---	---	---	---	---	---	0.06	0.14

1) parabolic plug

2) V-ported plug with linear characteristic, parabolic plug with equal-percentage, LDMspline® and parabolic characteristic.

Perforated plug available only with Kvs values in shadowed frames with the following restrictions:

- Kvs values 2.5 to 1.0 m³/hour available with linear characteristic only.
- Perforated plug with Kvs value acc. to column No. 2 available with linear or parabolic characteristic only.

metal - version with metal - metal seat sealing

PTFE - version with metal - PTFE seat sealing

Bellows packing can be used with V-ported plug only.

Equal-percentage, LDMspline® and parabolic characteristic available on condition : Kvs value ≥ 1.0

Max. differential pressure Δp for valves PN 16 must be 1.6 MPa.

Max. differential pressures specified in table apply to PTFE and O-ring packing. Δp_{max} for bellows must be consulted with the producer.

Dimensions and weights for the type RV 2x1

DN	PN 16					PN 40					PN 16, PN 40														
	D ₁	D ₂	D ₃	d	n	D ₁	D ₂	D ₃	d	n	D	f	D ₄	D ₅	L	V ₁	V ₂	[#] V ₂	V ₃	[#] V ₃	a	m ₁	m ₂	[#] m _v	
	mm	mm	mm	mm		mm	mm	mm	mm		mm	mm	mm	mm	mm	mm	mm	mm	mm	mm	mm	kg	kg	kg	
15	95	65	45	14	4	95	65	45	14	4	15	2	44	10	130	68	47	---	143	---	16	4.5	5.5	---	
20	105	75	58			105	75	58			14				20	150	68	47	---	143	---	18	5.5	6.5	---
25	115	85	68			115	85	68			18				25	160	85	52	250	148	346	18	6.5	8	3.5
32	140	100	78			140	100	78			18				32	180	85	52	250	148	346	20	8	9.5	3.5
40	150	110	88			150	110	88			18				40	200	85	52	250	148	346	20	9	11	3.5
50	165	125	102			165	125	102			18				50	230	117	72	270	168	366	20	14	21	3.5
65	185	145	122			185	145	122			18				65	290	117	72	270	168	366	22	18	27	3.5
80	200	160	138			200	160	138			18				80	310	152	106	452	222	568	24	26	40	4.5
100	220	180	158	8	8	235	190	162	22	100	14	14	350	152	106	452	222	568	24	38	49	4.5			
125	250	210	188			270	220	188	26	125			400	175	134	480	250	596	26	58	82	5			
150	285	240	212			300	250	218	26	150			480	200	134	480	250	596	28	78	100	5			

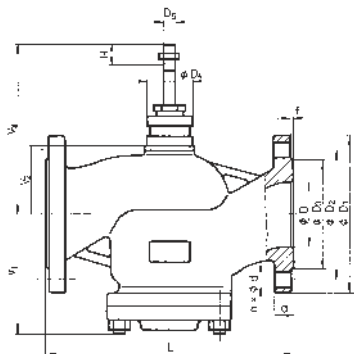

with regard of the standard previously in force, there is an option to have the number of connection bolts as stipulated in ČSN-EN 1092-1

[#]) - for valve with bellows packing

m_v- weight to be added to weight of valve equipped with bellows packing

m₁- for valves RV / HU 211

m₂- for valves RV / HU 221 and RV / HU 231



Control valves and Fail-safe action valves DN 25 - 150, PN 16 and 40 with Siemens actuators (Landis & Staefa)

Description

Control valves RV 213, RV 223 and RV 233 (further in text RV 2x3) are single-seated valves with pressure-balanced plug designed for regulation and shut-off of process medium flow. Its design enables the valve to be applicable to regulation at high differential pressures with low-linear-force-actuator. Flow characteristics, Kvs values and leakage rates correspond to international standards.

Valves with a fail-safe action series HU 2x3 have the same design as RV 2x3 with addition of increased seat sealing. Valves are equipped with fail-safe action actuators (valve closes upon power failure).

Valves RV 2x3 L are especially designed for Siemens actuators (Landis & Staefa).

Application

These valves have a wide range of application in heating, ventilation, power generation and chemical processing industries. Valve body can be optionally made of spheroidal cast iron, cast steel and austenitic stainless steel according to operating conditions.

The materials selected correspond to the recommendation of ČSN-EN 1503-1 (1/2002) (steels) and ČSN-EN 1503-3 (1/2002) (cast). The maximal operating pressures in behaviour with a chosen material and process medium temperature are mentioned in the table on page 28 of this catalogue.

Process media

Valves series RV / HU 2x3 are designed for regulation (RV 2x3) and for regulation and shut-off (HU 2x3) of flow and pressure of liquids, gases and vapours without abrasive particles e.g. Water, steam, air and other media compatible with material of the valve inner parts. The application of valves made of spheroidal cast iron (RV 213) for steam is limited by the following parameters: Steam must be superheated (its dryness $x_s \geq 0,98$) and inlet pressure $p_1 \leq 0,4$ Mpa when differential pressure is above-critical or $p_1 \leq 1,6$ MPa when differential pressure is under-critical. In case these values are exceeded, it is necessary to use valve made of cast steel (RV 223). To ensure reliable regulation, producer recommends to pipe a strainer in front of the valve or ensure in any other way that medium will not contain abrasive particles or impurities.

Installation

The valve is to be piped the way so that the direction of medium flow will coincide with the arrows on the body.

The valve can be installed in any position except position when the actuator is under the valve body. When medium temperature exceeds 150°C, it is necessary to protect the actuator against glowing heat from the pipeline e.g. by the means of proper insulating of the pipeline and valve or by tilting the valve away from the heat radiation.

Detailed informations for installation are included in „Instructions for installation and service” manual.

Technical data

Series	RV / HU 213	RV / HU 223	RV / HU 233
Type of valve	Two-way, single-seated, reverse, control valve with pressure-balanced plug		
Nominal size range	DN 25 to 150		
Nominal pressure	PN 16, PN 40		
Body material	Spheroidal cast iron EN-JS 1025 (EN-GJS-400-10-LT)	Cast steel 1.0619 (GP240GH) 1.7357 (G17CrMo5-5)	Stainless steel 1.4581 (GX5CrNiMoNb19-11-2)
Seat material : DN 25 - 50	1.4028 / 17 023.6	1.4028 / 17 023.6	1.4571 / 17 347.4
DIN W.Nr./ČSN DN 65 - 150	1.4027 / 42 2906.5	1.4027 / 42 2906.5	1.4581 / 42 2941.4
Plug material : DN 25 - 65	1.4021 / 17 027.6	1.4021 / 17 027.6	1.4571 / 17 347.4
DIN W.Nr./ČSN DN 80 - 150	1.4027 / 42 2906.5	1.4027 / 42 2906.5	1.4581 / 42 2941.4
Operating temperature range	-20 to 260°C	-20 to 260°C	-20 to 260°C
Face to face dimensions	Line 1 acc. to ČSN-EN 558-1 (3/1997)		
Connection flanges	Acc. to ČSN-EN 1092-1 (4/2002)		
Flange face	Type B1 (raised-faced) acc. to ČSN-EN 1092-1 (1/1999)	Type B1 (raised-faced) or Type F (female) or Type D (groove) acc. to ČSN-EN 1092-1 (2/2003)	
Type of plug	V-ported, perforated		
Flow characteristic	Linear, equal-percentage, LDMspline®, parabolic		
Kvs value	4 to 360 m ³ /hour		
Leakage rate	Class III. acc. to ČSN-EN 1349 (5/2001) (<0.1% Kvs) for c. valves with metal-metal seat sealing Class IV. acc. to ČSN-EN 1349 (5/2001) (<0.01% Kvs) for c. valves with metal-PTFE seat sealing		
Rangeability r	50 : 1		
Packing	O - ring EPDM $t_{max}=140^{\circ}C$, DRSpack® (PTFE) $t_{max}=260^{\circ}C$, Bellows $t_{max}=260^{\circ}C$		

Kvs values and differential pressures

Δp_{max} value is the valve max. differential pressure when open-close function is always guaranteed. In regard of service life of seat and plug, it is recommended so that

differential pressure would not exceed 1.6 MPa. Otherwise it is suitable to use perforated plug or sealing surfaces of seat and plug with a hard metal overlay.

For further information on actuating, see catalogue sheets		Actuating (actuator)						SQX ...		SAX ...		SKD ...		SKB ...		SKC ...	
		Marking in valve spec. No.						ELA, ELB		ELE		HLA, HLB, HLC		HLD, HLE, HLF		HLG, HLH, HLI	
		Linear force						700 N		800 N		1000 N		2800 N		2800 N	
DN	H	Kvs [m ³ /h]						Δp_{max}		Δp_{max}		Δp_{max}		Δp_{max}		Δp_{max}	
		1	2	3	4	5	6	metal	PTFE	metal	PTFE	metal	PTFE	metal	PTFE	metal	PTFE
15		---	2.5 ¹⁾	1.6 ¹⁾	1.0 ¹⁾	0.6 ¹⁾	0.4 ¹⁾	4.00	---	4.00	---	4.00	---	4.00	---	---	---
15		4.0 ¹⁾	---	---	---	---	---	2.82	---	3.40	---	4.00	---	4.00	---	---	---
20		---	---	2.5 ¹⁾	1.6 ¹⁾	1.0 ¹⁾	0.6 ¹⁾	4.00	---	4.00	---	4.00	---	4.00	---	---	---
20		---	4.0 ¹⁾	---	---	---	---	2.82	---	3.40	---	4.00	---	4.00	---	---	---
20		6.3 ¹⁾	---	---	---	---	---	1.27	---	1.56	---	2.15	---	4.00	---	---	---
25	20	---	---	---	2.5 ¹⁾	1.6 ¹⁾	1.0 ¹⁾	4.00	---	4.00	---	4.00	---	4.00	---	---	---
25		10.0	6.3 ²⁾	4.0 ²⁾	---	---	---	0.69	1.11	0.88	1.29	1.24	1.65	4.00	4.00	---	---
32		---	---	---	4.0 ¹⁾	---	---	2.82	---	3.40	---	4.00	---	4.00	---	---	---
32		16.0	10.0	6.3 ²⁾	---	---	---	0.34	0.66	0.45	0.77	0.67	0.99	2.66	2.98	---	---
40		25.0	16.0	10.0	---	---	---	0.16	0.42	0.23	0.49	0.38	0.63	1.66	1.91	---	---
50		40.0	25.0	16.0	---	---	---	0.06	0.25	0.10	0.29	0.18	0.37	0.95	1.14	---	---
65		63.0	40.0	25.0	---	---	---	---	0.15	0.02	0.17	0.07	0.22	0.54	0.69	---	---
80		100.0	63.0	40.0	---	---	---	---	---	---	---	---	---	---	---	0.34	0.47
100	40	160.0	100.0	63.0	---	---	---	---	---	---	---	---	---	---	---	0.20	0.30
125		250.0	160.0	100.0	---	---	---	---	---	---	---	---	---	---	---	0.11	0.19
150		360.0	250.0	160.0	---	---	---	---	---	---	---	---	---	---	---	0.06	0.14

1) linear characteristic only

metal - version with metal - metal seat sealing

PTFE - version with metal - PTFE seat sealing

(xx) - Δp_{max} values specified in parentheses apply to perforated plug.

Max Δp for valves PN 16 must be 1.6 MPa.

Max. differential pressures specified in table apply to PTFE and O-ring packing. Δp_{max} for bellows must be consulted with the producer.

Perforated plug available only with Kvs values in shadowed frames with the following restrictions:

- perforated plug with Kvs value acc. to column No. 2 available with linear or parabolic characteristic only.

Dimensions and weights for the type RV 2x3

DN	PN 16					PN 40					PN 16, PN 40																
	D ₁	D ₂	D ₃	d	n	D ₁	D ₂	D ₃	d	n	D	f	D ₄	D ₅	L	V ₁	V ₂	[#] V ₂	V ₃	[#] V ₃	a	m ₁	m ₂	[#] m _v			
	mm	mm	mm	mm		mm	mm	mm	mm		mm	mm	mm	mm	mm	mm	mm	mm	mm	mm	mm	kg	kg	kg			
15	95	65	45	14	4	95	65	45	14	4	15	2	44	10	130	68	47	---	143	---	16	4.5	5.5	---			
20	105	75	58			105	75	58			20				150	68	47	---	143	---	18	5.5	6.5	---			
25	115	85	68	115		85	68	25	160		85				52	250	148	346	18	6.5	8	3.5					
32	140	100	78	140		100	78	32	180		85				52	250	148	346	20	8	9.5	3.5					
40	150	110	88	150	110	88	40	200	85	52	250				148	346	20	9	11	3.5							
50	165	125	102	165	125	102	50	230	117	72	270				168	366	20	14	21	3.5							
65	185	145	122	4 ¹⁾	8	185	145	122	18	8	65				2	44	14	290	117	72	270	168	366	22	18	27	3.5
80	200	160	138			200	160	138			80							310	152	106	452	222	568	24	26	40	4.5
100	220	180	158	235		190	162	22	350		152							106	452	222	568	24	38	49	4.5		
125	250	210	188	270		220	188	26	400		175							134	480	250	596	26	58	82	5		
150	285	240	212	22	300	250	218	150	480	200	134							480	250	596	28	78	100	5			

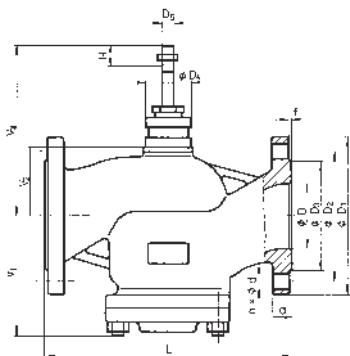

¹⁾ with regard of the standard previously in force, there is an option to have the number of connection bolts as stipulated in ČSN-EN 1092-1

^{#)} - for valve with bellows packing

m_v - weight to be added to weight of valve equipped with bellows packing

m₁ - for valves RV / HU 213

m₂ - for valves RV / HU 223 and RV / HU 233



Control valves DN 15 - 150, PN 16 and 40 with Siemens actuators (Landis & Staefa)

Description

Control valves RV 215, RV 225 and RV 235 (further only RV 2x5) are three-way valves with mixing or flow-diverting function. In regard of used actuators, the valves are suitable for regulation at lower differential pressures. Flow characteristics, Kvs values and leakage rates correspond to international standards.

When assembled with a fail-safe action actuator, it closes straight way upon power failure.

Valves RV 2x5 L are especially designed for Siemens actuators (Landis & Staefa).

Application

These valves have a wide range of application in heating, ventilation, power generation and chemical processing industries. Valve body can be optionally made of spheroidal cast iron, cast steel and austenitic stainless steel according to operating conditions.

The materials selected correspond to the recommendation of ČSN-EN 1503-1 (1/2002) (steels) and ČSN-EN 1503-3 (1/2002) (cast). The maximal operating pressures in behaviour with a chosen material and process medium temperature are mentioned in the table on page 33 of this catalogue.

Process media

Valves series RV 2x5 are designed for regulation of flow and pressure of liquids, gases and vapours without abrasive

particles e.g. water, steam, air and other media compatible with material of the valve inner parts. The application of valves made of spheroidal cast iron (RV 215) for steam is limited by the following parameters: Steam must be superheated (its dryness $x_1 \geq 0,98$) and inlet pressure $p_1 \leq 0,4$ MPa when differential pressure is above-critical or $p_1 \leq 1,6$ MPa when differential pressure is under-critical. In case these values are exceeded, it is necessary to use valve made of cast steel (RV 225). To ensure reliable regulation, producer recommends to pipe a strainer in front of the valve or ensure in any other way that medium will not contain abrasive particles or impurities.

Installation

When the valve is used as mixing, it must be piped the way so that direction of process medium flow will coincide with the arrows on the body (inlet ports A, B and outlet port AB). When the valves is used as diverting, process medium flows through common valve port AB and split streams leave through valve ports A and B). The valve can be installed in any position except position when the actuator is under the valve body. When medium temperature exceeds 150°C, it is necessary to protect the actuator against glowing heat from the pipeline e.g. by the means of proper insulating of the pipeline and valve or by tilting the valve away from the heat radiation.

Detailed informations for installation are included in „Instructions for installation and service” manual.

Technical data

Series	RV 215	RV 225	RV 235
Type of valve	Three-way, reverse, control valve		
Nominal size range	DN 15 to 150		
Nominal pressure	PN 16, PN 40		
Body material	Spheroidal cast iron EN-JS 1025 (EN-GJS-400-10-LT)	Cast steel 1.0619 (GP240GH) 1.7357 (G17CrMo5-5)	Stainless steel 1.4581 (GX5CrNiMoNb19-11-2)
Seat material : DN 15 - 50	1.4028 / 17 023.6	1.4028 / 17 023.6	1.4571 / 17 347.4
DIN W.Nr./ČSN DN 65 - 150	1.4027 / 42 2906.5	1.4027 / 42 2906.5	1.4581 / 42 2941.4
Plug material : DN 15 - 65	1.4021 / 17 027.6	1.4021 / 17 027.6	1.4571 / 17 347.4
DIN W.Nr./ČSN DN 80 - 150	1.4027 / 42 2906.5	1.4027 / 42 2906.5	1.4581 / 42 2941.4
Operating temperature range	-20 to 300°C	-20 to 500°C	-20 to 300°C
Face to face dimensions	Line 1 acc. to ČSN-EN 558-1 (3/1997)		
Connection flanges	Acc. to ČSN-EN 1092-1 (4/2002)		
Flange face	Type B1 (raised-faced) acc. to ČSN-EN 1092-1 (1/1999)	Type B1 (raised-faced) or Type F (female) or Type D (groove) acc. to ČSN-EN 1092-1 (2/2003)	
Type of plug	V-ported, perforated		
Flow characteristic	Linear, equal-percentage in straight way		
Kvs value	1.6 to 360 m ³ /hour		
Leakage rate in A-AB way	Class III. acc. to ČSN-EN 1349 (5/2001) (<0.1% Kvs) for c. valves with metal-metal seat sealing Class IV. acc. to ČSN-EN 1349 (5/2001) (<0.01% Kvs) for c. valves with metal-PTFE seat sealing		
Leakage rate in B-AB way	Not guaranteed > 2% Kvs		
Rangeability r	50 : 1		
Packing	O - ring EPDM $t_{max}=140^{\circ}C$, DRSpack® (PTFE) $t_{max}=260^{\circ}C$, Bellows $t_{max}=550^{\circ}C$		

Kvs values and differential pressures

Δp_{max} value is the valve max. differential pressure when open-close function is always guaranteed. In regard of service life of seat and plug, it is recommended so that

differential pressure would not exceed 1.6 MPa. Otherwise it is suitable to use perforated plug or sealing surfaces of seat and plug with a hard metal overlay.

For further information on actuating see actuators' catalogue sheets		Actuating (actuator)			SQX ...	SAX ...	SKD ...	SKB ...	SKC ...					
		Marking in valve specification No.			ELA, ELB	ELE	HLA, HLB, HLC	HLD, HLE, HLF	HLG, HLH, HLI					
		Linear force			700 N	800 N	1000 N	2800 N	2800 N					
		Kvs [m ³ /h]			Δp_{max}	Δp_{max}	Δp_{max}	Δp_{max}	Δp_{max}					
DN	H	1	2	3	kov	PTFE	kov	PTFE	kov	PTFE	kov	PTFE	kov	PTFE
15	20	---	2.5 ¹⁾	1.6 ¹⁾ 1)	4.00	---	4.00	---	4.00	---	4.00	---	---	---
15		4.0 ¹⁾	---	---	2.82	---	3.40	---	4.00	---	4.00	---	---	---
20		---	---	2.5 ¹⁾ 1)	4.00	---	4.00	---	4.00	---	4.00	---	---	---
20		---	4.0 ¹⁾	---	2.82	---	3.40	---	4.00	---	4.00	---	---	---
20		6.3 ¹⁾	---	---	1.27	---	1.56	---	2.15	---	4.00	---	---	---
25		10.0	6.3 ²⁾	4.0 ²⁾ 1)	0.69	--	0.88	1.29	1.24	1.65	4.00	4.00	---	---
32		16.0	10.0	6.3 ²⁾	0.34	1.11	0.45	0.77	0.67	0.99	2.66	2.89	---	---
40		25.0	16.0	10.0	0.16	---	0.23	0.49	0.38	0.63	1.66	1.91	---	---
50		40.0	25.0	16.0	0.06	0.25	0.10	0.29	0.18	0.37	0.95	1.14	---	---
65		63.0	40.0	25.0	---	0.15	0.02	0.17	0.07	0.22	0.54	0.69	---	---
80	40	100.0	63.0	40.0	---	---	---	---	---	---	---	---	0.34	0.47
100		160.0	100.0	63.0	---	---	---	---	---	---	---	---	0.20	0.30
125		250.0	160.0	100.0	---	---	---	---	---	---	---	---	0.11	0.19
150		360.0	250.0	160.0	---	---	---	---	---	---	---	---	0.06	0.14

- 1) parabolic plug in straight way, V-ported plug in angle way
- 2) V-ported plug in angle way, in straight way for linear characteristic V-ported plug and for equal-percentage characteristic parabolic plug.

metal - version with metal - metal seat sealing

PTFE - version with metal - PTFE seat sealing (does not apply to contoured plugs)

Max. differential pressures specified in table apply to PTFE and O-ring packing. Δp for bellows must be consulted with the producer.

Bellows packing can be used with V-ported plug only.

Max. differential pressure Δp for valves PN 16 must be 1.6 MPa.

Dimensions and weights for the type RV 2x5

DN	PN 16					PN 40					PN 16, PN 40													
	D ₁	D ₂	D ₃	d	n	D ₁	D ₂	D ₃	d	n	D	f	D ₄	D ₅	L	V ₁	V ₂	[#] V ₂	V ₃	[#] V ₃	a	m ₁	m ₂	[#] m _v
	mm	mm	mm	mm		mm	mm	mm	mm		mm	mm	mm	mm	mm	mm	mm	mm	mm	mm	mm	kg	kg	kg
15	95	65	45	14	4	95	65	45	14	4	15	2	44	10	130	110	47	---	143	---	16	5.5	6	---
20	105	75	58			105	75	58			20				150	115	47	---	143	---	18	6.5	7	---
25	115	85	68			115	85	68			25				160	130	52	250	148	346	18	8.3	9.5	3.5
32	140	100	78			140	100	78			32				180	135	52	250	148	346	20	10.5	12	3.5
40	150	110	88			150	110	88			40				200	140	52	250	148	346	20	12	13.5	3.5
50	165	125	102			165	125	102			50				230	175	72	270	168	366	20	17	24	3.5
65	185	145	122			185	145	122			65				290	180	72	270	168	366	22	22	31	3.5
80	200	160	138			200	160	138			80				310	220	106	452	222	568	24	31	43	4.5
100	220	180	158			235	190	162			22				350	230	106	452	222	568	24	44	55	4.5
125	250	210	188			270	220	188			26				400	260	134	480	250	596	26	65	90	5
150	285	240	212	300	250	218	26	480	290	134	480	250	596	28	94	120	5							

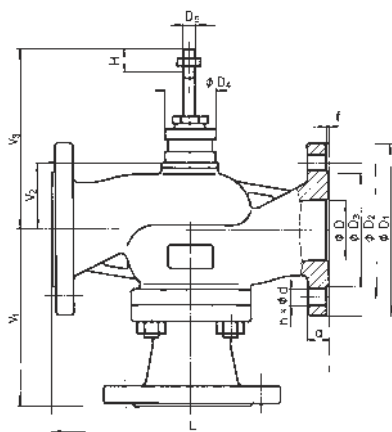

¹⁾ with regard of the standard previously in force, there is an option to have the number of connection bolts as stipulated in ČSN-EN 1092-1

^{#)} - for valve with bellows packing

m_v - weight to be added to weight of valve equipped with bellows packing

m₁ - for valves RV 215

m₂ - for valves RV 225 and RV 235

Valve complete specification No. for ordering RV / HU 2x1, RV / HU 2x3, RV 2x5

		XX	X X X	X X X	X X X X	X X	- XX	/ XXX	- XXX
1. Valve	Control valve	RV							
	Fail-safe action valve	HU							
2. Series	Valves made of sph. cast iron EN-JS 1025	2 1							
	Valves made of cast steel 1.0619, 1.7357	2 2							
	Valves made of stainless steel 1.4581	2 3							
	Reverse valve		1						
	Pressure-balanced, reverse valve		3						
	Mixing (diverting), reverse valve		5						
3. Actuating ¹⁾ Fail-safe action actuators	Electric actuator			E					
	Electrohydraulic actuator			H					
	SQX 32.00, SQX 32.03, SQX 82.00, SQX 82.03			E L A					
	SQX 62			E L B					
	SAX 31, SAX 61, SAX 81			E L E					
	SKD 32.50, SKD 82.50, SKD 82.8, SKD 62.9			H L A					
	SKD 32.51, SKD 32.21, SKD 82.51 ¹⁾			H L B					
	SKD 62, SKD 62U ¹⁾			H L C					
	SKB 32.50, SKB 82.50, SKB 62.9			H L D					
	SKB 32.51, SKB 82.51 ¹⁾			H L E					
	SKB 62, SKB 62U ¹⁾			H L F					
	SKC 32.60, SKC 82.60, SKC 62.9			H L G					
	SKC 32.61, SKC 82.61 ¹⁾			H L H					
	SKC 62, SKC 62U ¹⁾			H L I					
4. Connection	Raised flange				1				
	Female flange				2				
5. Body material <i>(Operating temperature ranges are specified in parentheses)</i>	Cast steel 1.0619 (-20 to 400°C)				1				
	Sphr. cast iron EN-JS 1025 (-20 to 300°C)				4				
	CrMo steel 1.7357 (-20 to 500°C)				7				
	Stainless steel 1.4581 (-20 to 400°C)				8				
	Other material on request				9				
6. Seat sealing ³⁾ From DN 25; t _{max} = 260°C	Metal - metal				1				
	Soft sealing (metal - PTFE) in straight way ²⁾				2				
	Hard metal overlay on sealing surfaces				3				
7. Packing	O - ring EPDM				1				
	DRSpack® (PTFE)				3				
	Bellows				7				
	Bellows with safety PTFE packing				8				
8. Flow characteristic ⁴⁾ Not applicable to RV 2x5	Linear					L			
	Equal-percentage in straight way					R			
	LDMspline® ³⁾					S			
	Parabolic ³⁾					P			
	Linear - perforated plug ³⁾					D			
	Equal-percentage - perforated plug ³⁾					Q			
Parabolic - perforated plug ³⁾					Z				
9. Kvs	Column No. acc. to Kvs values table					X			
10. Nominal pressure PN	PN 16						16		
	PN 40						40		
11. Max. operating temp. °C ⁵⁾ Not applicable to RV / HU 2x3	O - ring EPDM							140	
	DRSpack® (PTFE), bellows							220	
	DRSpack® (PTFE), bellows							260	
	Bellows ⁴⁾							300	
12. Nominal size DN	DN								XXX

Ordering example: Two-way control valve DN 65, PN 40, with Siemens actuator (Landis & Staefa) SKB 32.50, body material: spheroidal cast iron, flange with raised face, metal-metal seat sealing, PTFE packing, linear characteristic, Kvs = 63 m³/hour is specified as follows: **RV 211 HLD 1413 L1 40/220-65**

Valves RV / HU 2x1

Section of valve with V-ported plug

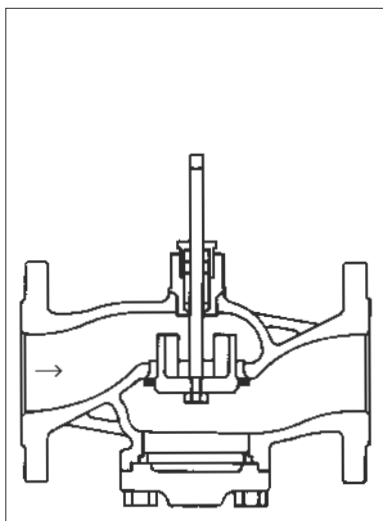

Section of valve with perforated plug

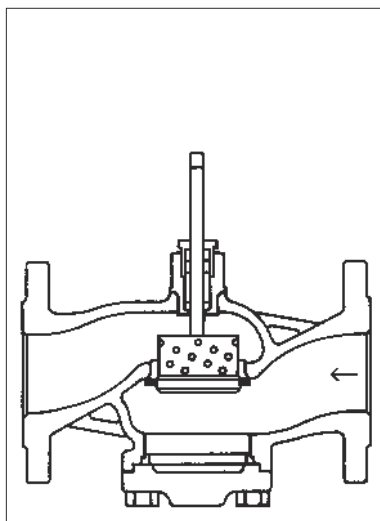

Valves RV / HU 2x3

Section of pressure-balanced valve with V-ported plug

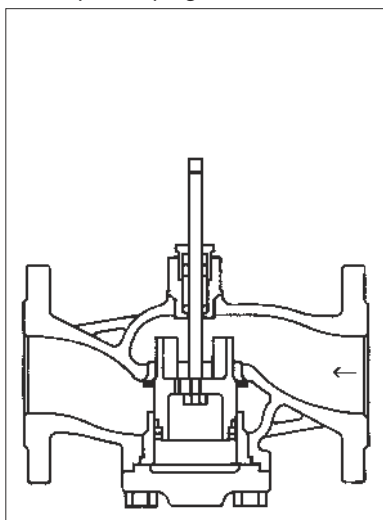

Section of pressure-balanced valve with perforated plug

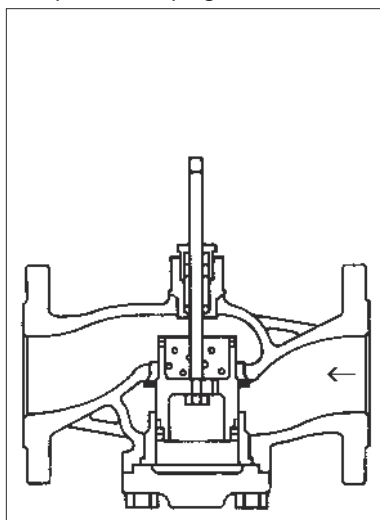

Valves RV 2x5

Section of three-way valve with V-ported plug

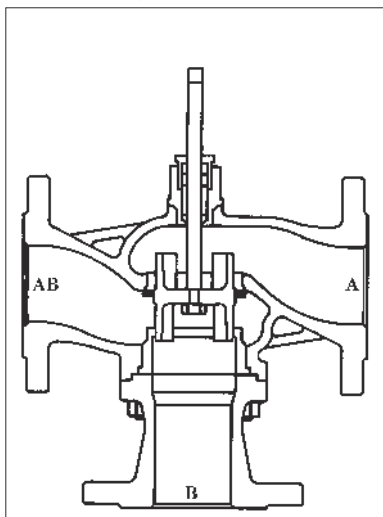



Electric actuators SQX 32..., SQX 82... Siemens (Landis & Staefa)

Technical data

Type	SQX 32.00	SQX 32.03	SQX 82.00	SQX 82.03
Mark in valve spec. No.	ELA			
Voltage	230 V AC		24 V AC	
Frequency	50...60 Hz			
Power consumption	3 VA	6,5 VA	3 VA	6,5 VA
Control	3 - position control			
Open-close running time	150 s	35 s	150 s	35 s
Nominal force	700 N			
Travel	20 mm			
Enclosure	IP 54			
Process medium max. temp.	140°C (180°C when bellows or cooler is used)			
Ambient temp. range	-15 to 50°C			
Ambient humidity limit	5 to 95 %			
Weight	1,5 kg			

Accessories

1 potentiometer and 1 auxiliary switch ASZ7.4 0...1000 Ω

1 pair of auxiliary switches ASC9.4

1 auxiliary switch ASC9.5

Note : 1 piece of accessory can be installed in actuator only. With nominal stroke of actuator of 20 mm, the real range of potentiometer can be lower by even 25 %.

Dimensions of actuator

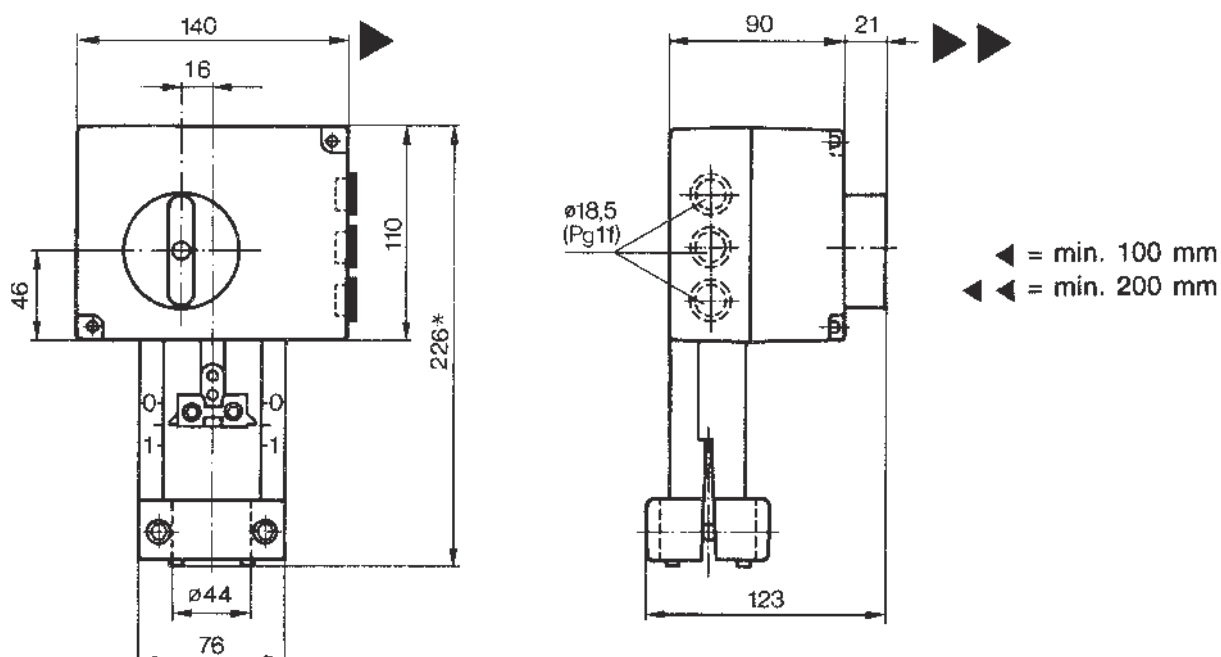

Wiring diagrams of actuators

SQX 32...

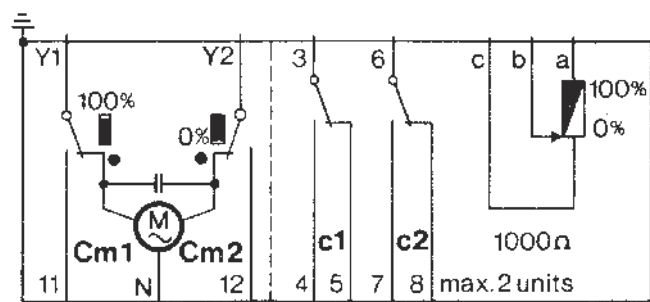

SQX 82...

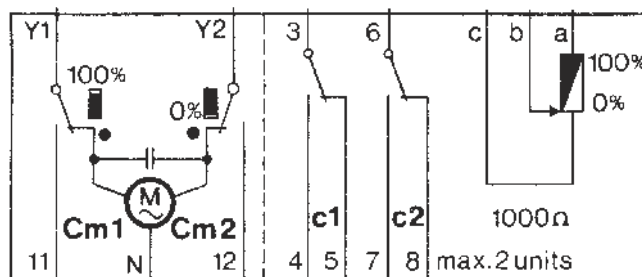

- Cm1 end switch
- Cm2 end switch
- c1 auxiliary switch ASC9.5
- c1,c2 pair of auxiliary switches ASC9.4
- c1,1000 Ω auxiliary switch and potentiometer
as a set ASZ7.4



**Electric actuators
SQX 62
Siemens (Landis & Staefa)**

Technical data

Type	SQX 62
Mark in valve spec. No.	ELB
Voltage	24 V AC
Frequency	50...60 Hz
Power consumption	6,5 VA
Control	0...10 V; 4 - 20 mA
Open-close running time	35 s
Nominal force	700 N
Travel	20 mm
Enclosure	IP 54
Process medium max. temperature	140°C (180°C when bellows or cooler is used)
Ambient temp. range	-15 to 50°C
Ambient humidity limit	0 to 95 % of relative humidity
Weight	1,6 kg

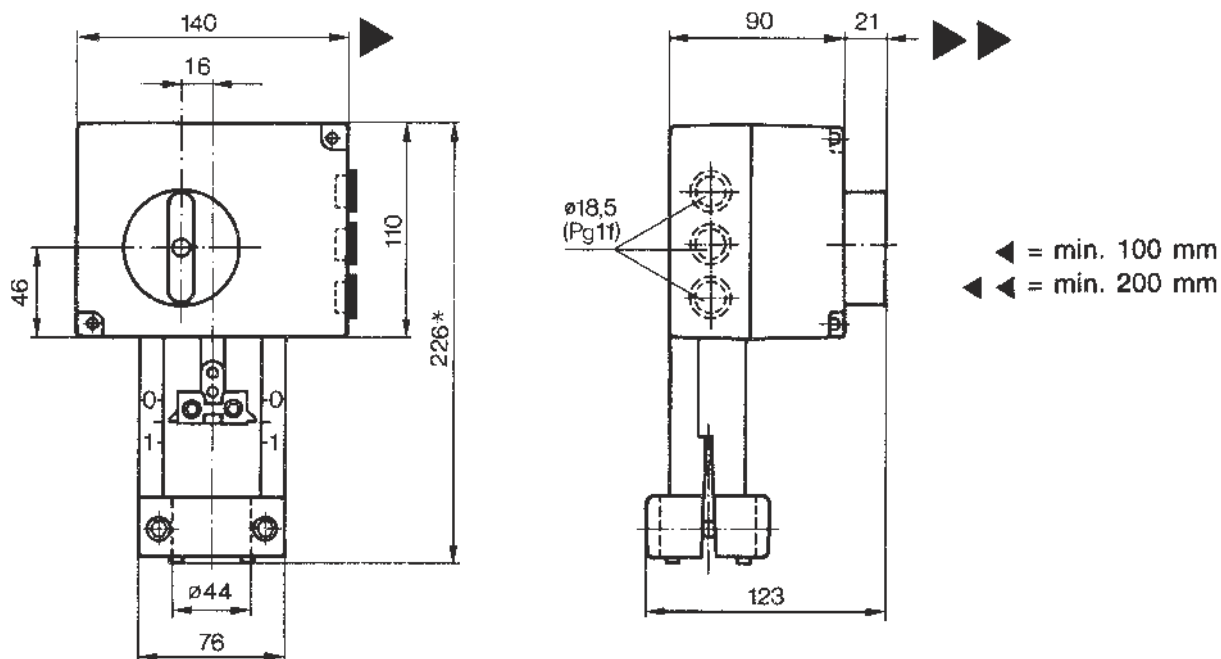
Dimensions of actuator

Wiring diagram of actuator SQX 62

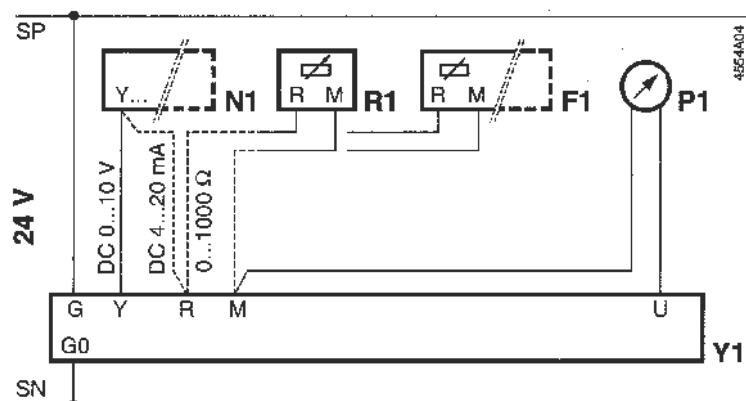

- Y1 actuator SQX62...
- N1 positioner
- F1 anti-frost thermostat with feedback of 0...1000 Ω (switch DIL No.2 switched to "1000 Ω" position)
- P1 position indicator
- R1 position transmitter with feedback of 0...1000 Ω (switch DIL No.2 switched to "1000Ω" position)

Terminal on terminal board

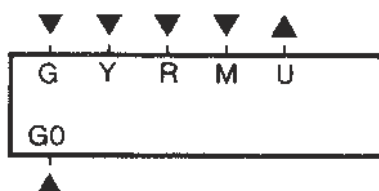

- G, G0 AC 24 V feeding voltage
 - G - system potential (SP)
 - G0 - system neutral (SN)
- Y control input signal DC 0...10 V
- R control input signal DC 4...20 mA or 0...1000 Ω (type of signal is selected by switch DIL No.2)
- M measuring neutral
- U feedback DC 0...10 V if there is DC 0...10 V or R = 0...1000 Ω on Y terminal (maximum availability from both signals), or feedback DC 4...20 mA if there is DC 4...20 mA on R terminal

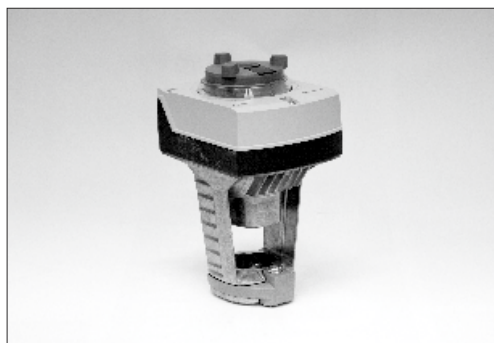
**Electric actuators
SAX
Siemens**
Technické parametry

Type	SAX 31.00	SAX 31.03	SAX 61.03	SAX 81.00	SAX 81.03
Mark in valve spec. No.	ELE				
Voltage	230 V AC		24 V AC/DC		
Frequency	50 Hz				
Power consumption	3,5 VA	8 VA	8 VA	3,5 VA	8 VA
Control	3 - point		0 - 10 V, 4 - 20 mA, 0 - 1000 Ω	3 - point	
Open-close running time	120 s	30 s	30 s	120 s	30 s
Nominal force	800 N				
Travel	20 mm				
Enclosure	IP 54				
Process medium max. temp.	150°C (180°C when bellows or cooler is used)				
Ambient and actuator surface temp. range	-15 to 55°C				
Ambient humidity limit	< 95 % r.v.				
Handle	yes				
Weight	1,8 kg				

See original producer's catalogue sheets for further information about actuators.

Accessories for actuators SAX31..., SAX81...

Auxiliary switch ASC10.51

2x auxiliary switch ASC10.51 (jen bez ASZ7.5)

Potentiometer 135 Ω ASZ7.5/135

Potentiometer 200 Ω ASZ7.5/200

Potentiometer 1000 Ω ASZ7.5/1000

Weather shield ASK39.1

Stem heating element (150°C...180°C)

Accessories for actuators SAX61...

Auxiliary switch ASC10.51

2x auxiliary switch ASC10.51 (jen bez AZX61.1)

Function module AZX61.1

Weather shield ASK39.1

Stem heating element (150°C...180°C)

Function module AZX61.1

The functional module allows sequential drive, adaptation of control signal and reversing signal.

Dimensions of actuator

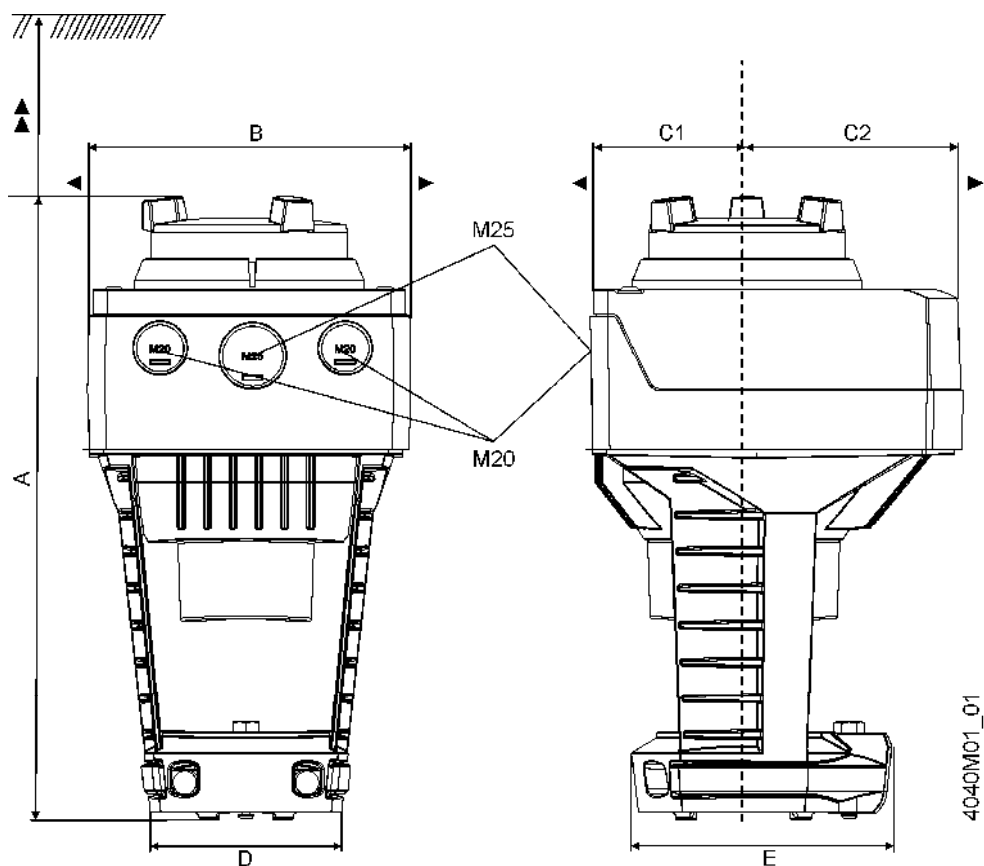

Product type	A	B	C	C1	C2	D	E	>	>>
SAX...	242	124	150	68	82	80	100	100	200
ASK39.1 cover included	+25	154	300	200	100	-	-	-	-

Dimensions in mm

Connection terminals

SAX31..

AC 230 V, 3-position

- N** — System neutral (SN)
- Y1** — Positioning signal (actuator's stem extends)
- Y2** — Positioning signal (actuator's stem retracts)

SAX61..

AC/DC 24 V, DC 0...10 V / 4...20 mA / 0...1000 Ω

- G0** — System neutral (SN)
- G** — System potential (SP)
- Y** — Positioning signal for DC 0...10 V / 4...20 mA
- M** — Measuring neutral
- U** — Position feedback DC 0...10 V
- Z** — Positioning signal forced control

SAX81..

AC/DC 24 V, 3-position

- G** — System potential (SP)
- Y1** — Positioning signal (actuator's stem extends)
- Y2** — Positioning signal (actuator's stem retracts)

Auxiliary switch
ASC10.51



Adjustable switching points, AC 24...230 V

- 1** — System potential (SP)
- 2** — Closing (actuator's spindle turns clockwise)
- 3** — Opening (actuator's spindle turns clockwise)

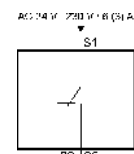

Potentiometer
ASZ7.5/..



Adjustment of zero point, DC 10 V

- 1** — Measuring neutral
- 2** — 0...x Ω
- 3** — x...0 Ω
x = 135 Ω, 200 Ω, 1000 Ω

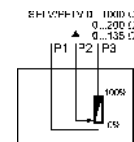

Connection diagrams

SAX31..

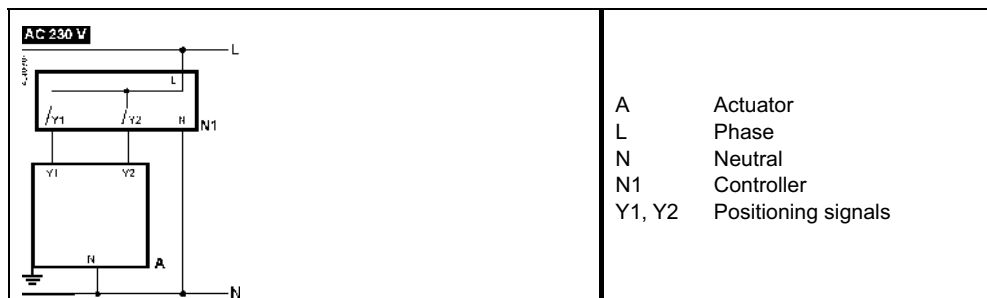

SAX61..

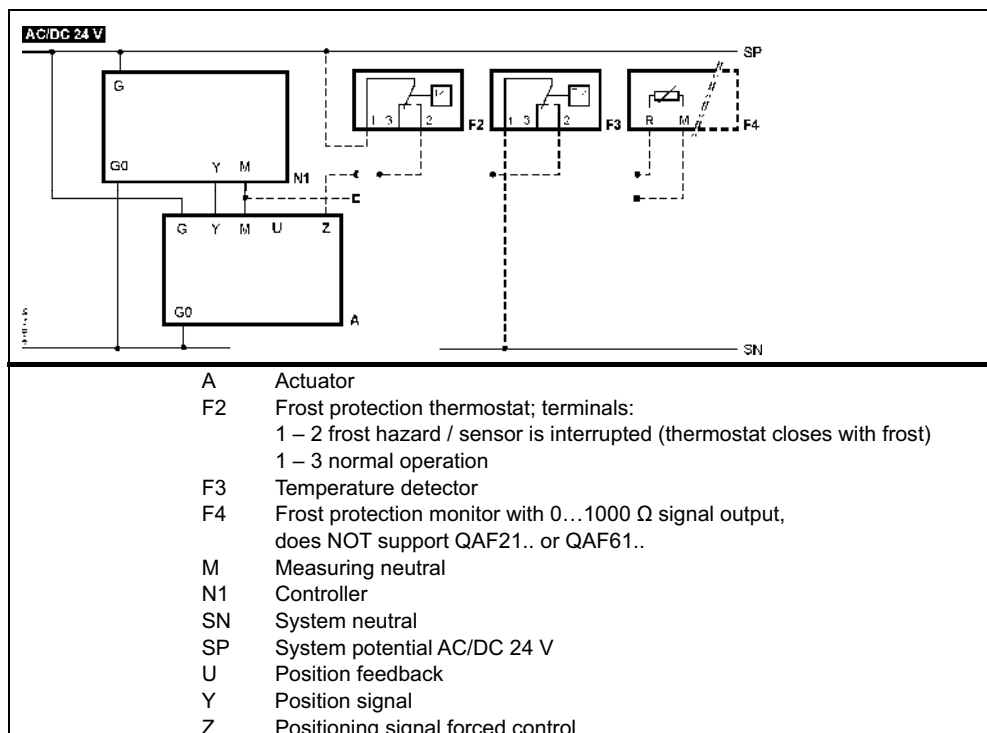

SAX81..

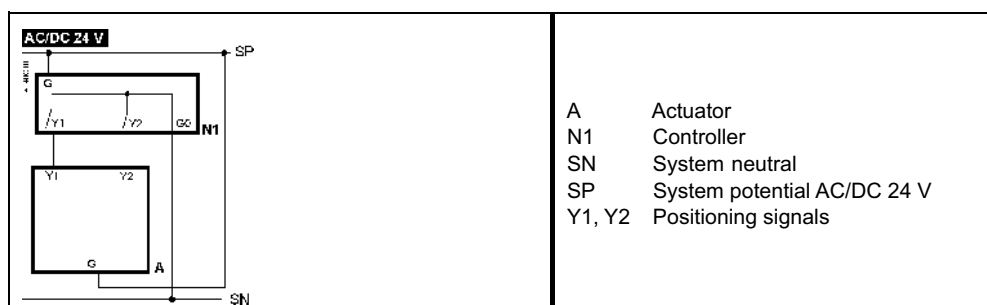



HLA
HLB

**Electrohydraulic actuators
SKD 32..., SKD 82...
Siemens (Landis & Staefa)**

Technical data

Type	SKD 32.50	SKD 82.50	SKD 32.51	SKD 32.21	SKD 82.51
Mark in valve spec. No.	HLA		HLB		
Voltage	230 V AC	24 V AC	230 V AC		24 V AC
Frequency	50...60 Hz				
Power consumption	10 VA		15 VA		
Control	3 - position		3 - position		
Running time open	120 s		120 s	30 s	120 s
Running time closed	120 s		120 s	10 s	120 s
Fail-safe action time	---		8 s		
Nominal force	1000 N				
Travel	20 mm				
Enclosure	IP 54				
Process medium max. t.	140°C (180°C when bellows or cooler is used)				
Ambient and actuator's surface temp. limit	-15 to 50°C				
Ambient humidity limit	5 - 95 % of relative humidity				
Weight	3,6 kg				

Accessories

Pair of auxiliary switches ASC9.3

Potentiometer 1000 Ω ASZ7.3 *)

Potentiometer 135 Ω ASZ7.31 *)

Potentiometer 200 Ω ASZ7.32 *)

*) 1 potentiometer can be used for 1 actuator only

Dimensions of actuator

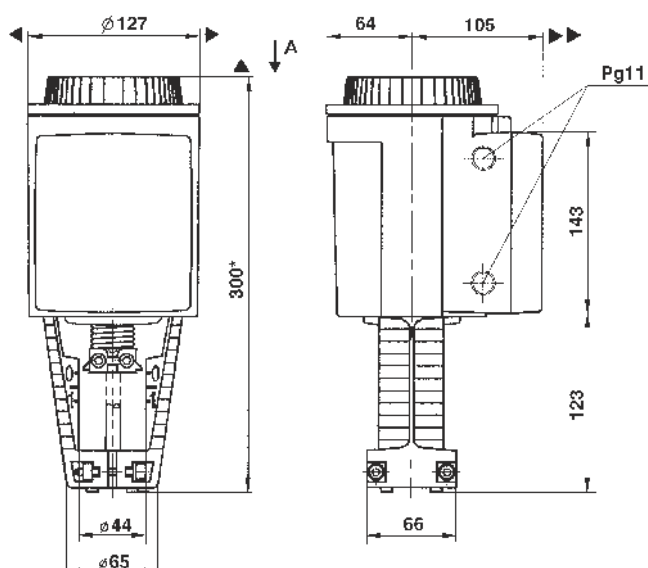

Connection diagrams

SKD32...
AC 230 V
3-position

SKD32.21, SKD32.51

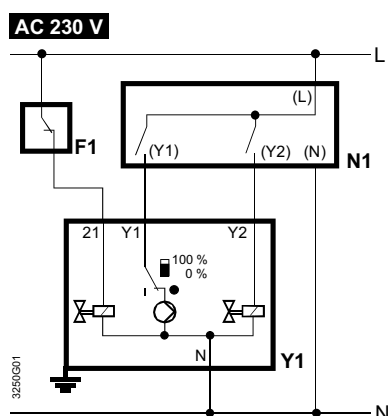

F1 Safety thermostat
N1, N2 Controllers
Y1, Y2 Actuators
L Phase
N Neutral conductor

SKD32.50

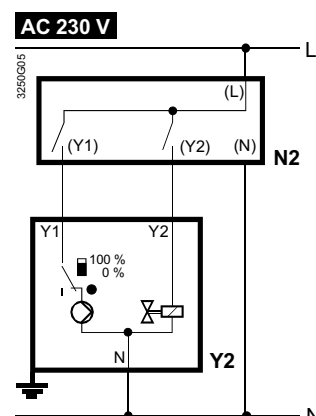

Y1 Control signal «Open»
Y2 Control signal «Close»
21 Spring-return function

SKD82...
AC 24 V
3-position

SKD82.51, SKD82.51U

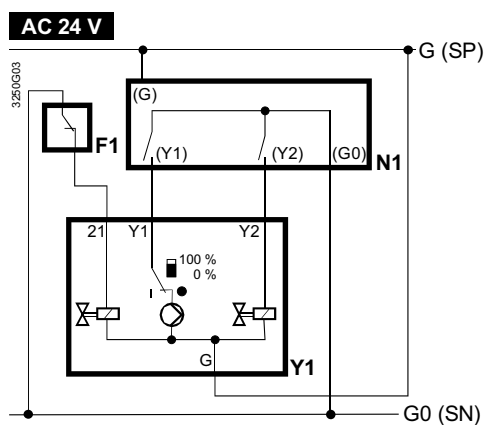

F1 Safety thermostat
N1, N2 Controllers
Y1, Y2 Actuators
SP System potential AC 24 V
SN System neutral

SKD82.50, SKD82.50U

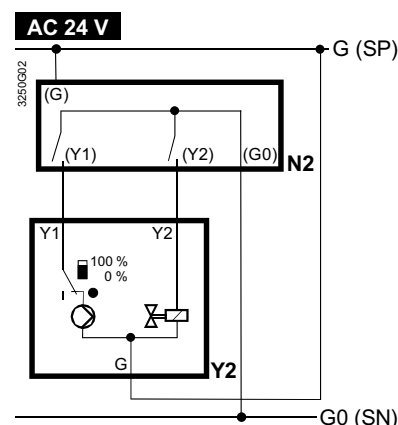

(Y1) (Y2) Controller contacts
Y1 Control signal «Open»
Y2 Control signal «Close»
21 Spring-return function



HLA
HLC

**Electrohydraulic actuators
SKD 60 and SKD 62...
Siemens (Landis & Staefa)**

Technical data

Type	SKD 60	SKD 62	SKD 62UA ^{*)}
Mark in valve spec. No.	HLA	HLC	
Voltage	24 V AC		
Frequency	50...60 Hz		
Power consumption	17 VA / 12 VA		
Control	0 - 10 V, 4 - 20 mA, 0 - 1000E		
Running time open	30 s		
closed	15 s		
Fail-safe action time	---	15 s	
Nominal force	1000 N		
Travel	20 mm		
Enclosure	IP 54		
Process medium max. t.	140°C (180°C when bellows or cooler is used)		
Ambient and actuator's surface temperature range	-15 to 50°C		
Ambient humidity range	0 - 95 % relative humidity		
Weight	3,6 kg	3,85 kg	3,6 kg

**) UA... version with improved electronics*

Accessories

Auxiliary switch 24 V ASC1.6 - not usable for valves RV102, RV103

Description

Each actuator with continuous control signal is equipped with ACT control technology enabling the following features as standard:

- stroke range calibration
- state indication via LED
- flow characteristic selection (log / lin)
- selection of control signal at Y terminal
- feedback signal at U terminal corresponding to control signal at Y terminal
- forced control at Z terminal

Version with improved electronics (UA) further enables:

- inversion of control signal
- sequence control
- stroke limiting

Dimensions of actuator

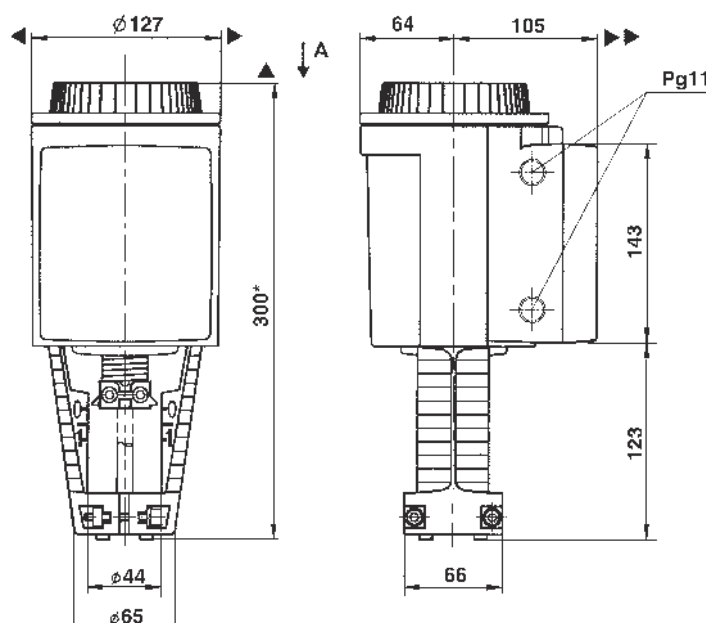

Connection terminals

SKD6...	G0	Operating voltage AC 24 V: system neutral (SN)
	G	Operating voltage AC 24 V: system potential (SP)
	Y	Positioning signal DC 0...10 (30) V or DC 4...20 mA
	M	Measuring neutral (=G0)
	U	Position indication DC 0...10 V or DC 4...20 mA
	Z	Override control

Auxiliary switch ASC1.6

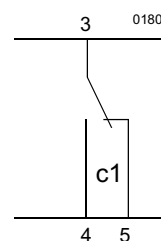

Connection diagrams

SKD6..
AC 24 V
DC 0...10 V, 4...20 mA,
0...1000 Ω

SKD60

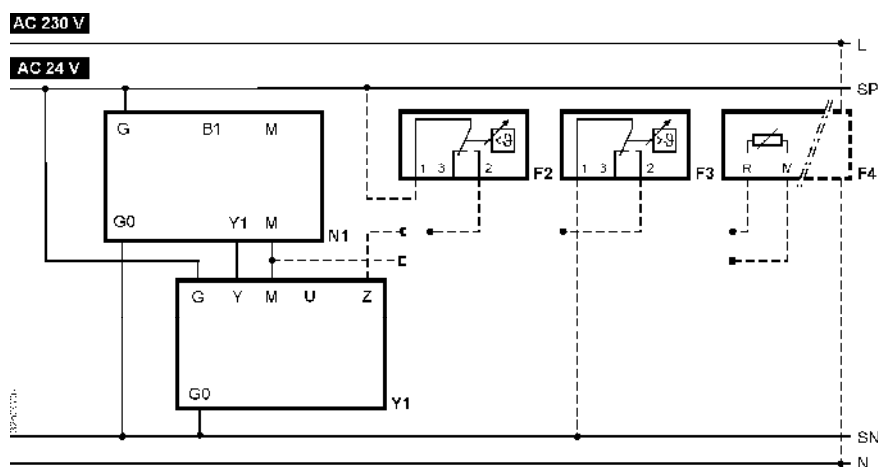

SKD62
SKD62UA

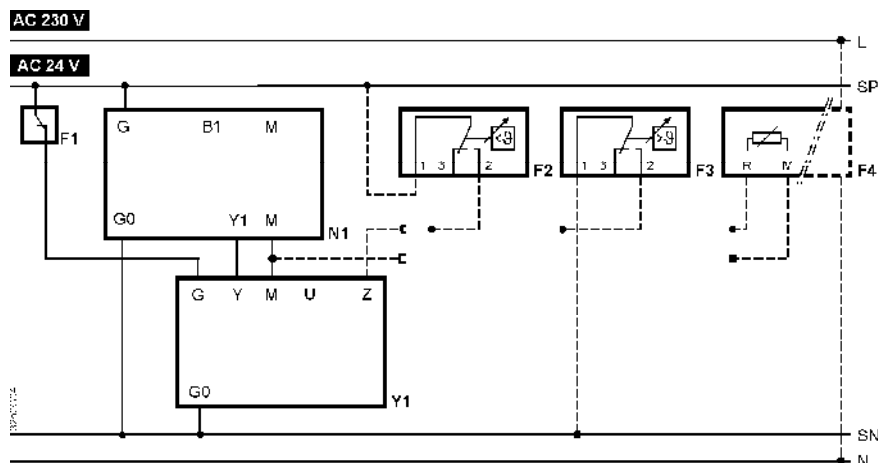

- Y1 Actuator
- N1 Controller
- F1 Temperature limiter
- F2 Frost protection thermostat
terminals: 1 – 3 frost hazard / sensor is interrupted
(thermostat closes with frost)
1 – 2 normal operation
- F3 Frost protection monitor
- F4 Frost protection monitor QAF21.. or QAF61.. (for SKD62UA only) *
- G (SP) System potential AC 24 V
- G0 (SN) Systémová neutral

* Only with sequence control and the appropriate selector switch settings

Rozměry

All dimensions in mm

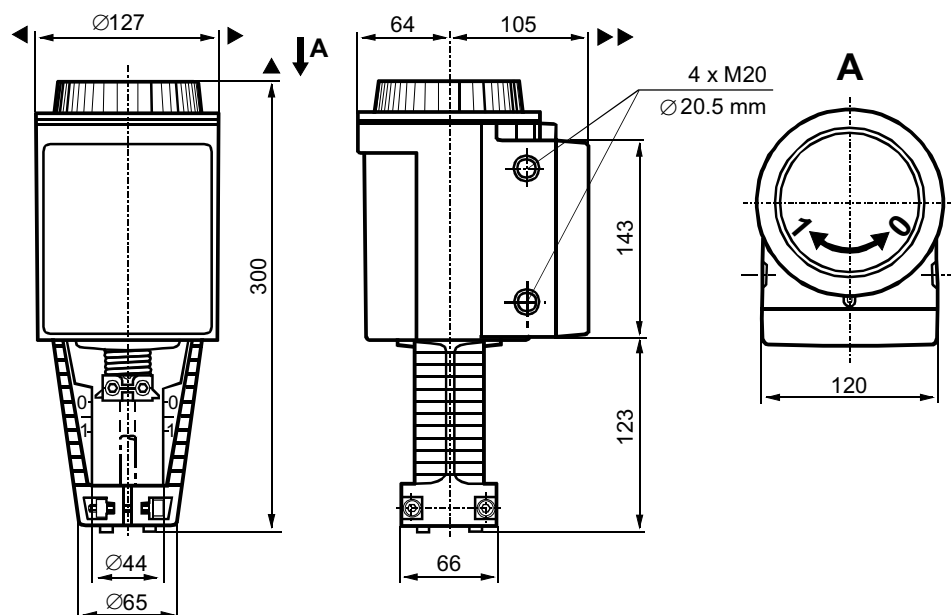

- ▲ = > 100 mm minimum clearance from ceiling or wall for mounting
- ▶▶ = > 200 mm connection, operation, maintenance etc.

HLD, HLE HLG, HLH



**Electrohydraulic actuators
SKB 32..., SKB 82...
SKC 32..., SKC 82...
Siemens (Landis & Staefa)**

Technical data

Type	SKB 32.50	SKB 82.50	SKB 32.51	SKB 82.51	SKC 32.60	SKC 82.60	SKC 32.61	SKC 82.61
Mark in valve spec. No.	HLD		HLE		HLG		HLH	
Voltage	230 V AC	24 V AC	230 V AC	24 V AC	230 V AC	24 V AC	230 V AC	24 V AC
Frequency	50...60 Hz							
Power consumption	10 VA		15 VA		19 VA		24 VA	
Control	3 - position							
Running time open	120 s		120 s		120 s		120 s	
Running time closed	120 s		120 s		120 s		120 s	
Fail-safe action time	---		10 s		---		18 s	
Nominal force	2800 N							
Travel	20 mm				40 mm			
Enclosure	IP 54							
Process medium max.t.	220°C (higher temperature with Bellows only)							
Ambient and actuator's surface temperature range	-15 to 50°C							
Ambient humidity range	0 - 95 % relative humidity							
Weight	8,4 kg		8,9 kg		10 kg		10,5 kg	

Accessories

Pair of auxiliary switches ASC9.3

Potentiometer 1000 Ω ASZ7.3 *)

Potentiometer 135 Ω ASZ7.31 *)

Potentiometer 200 Ω ASZ7.32 *)

*) 1 potentiometer can be used for 1 actuator only

Dimensions of actuator

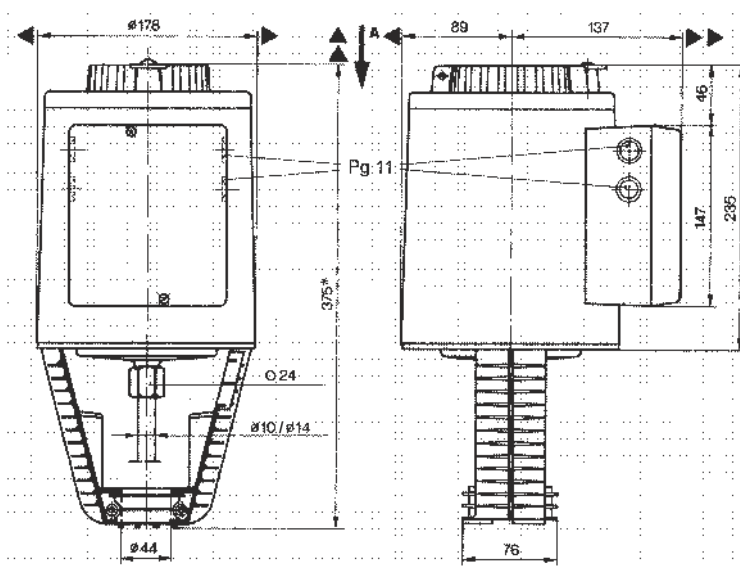

Schémata zapojení

SKB32.., SKC 32..
AC 230 V
3-position

SKB32.51, SKC 32.51

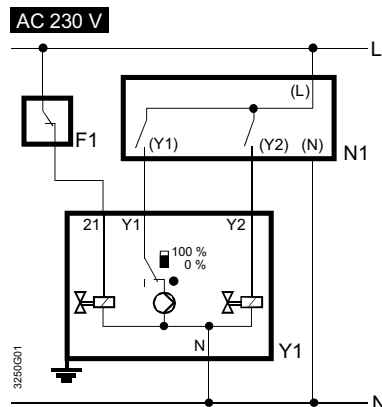

F1	Temperature limiter	L	Phase
N1, N2	Controller	N	Neutral
Y1, Y2	Actuators		

SKB32.50, SKC 32.50

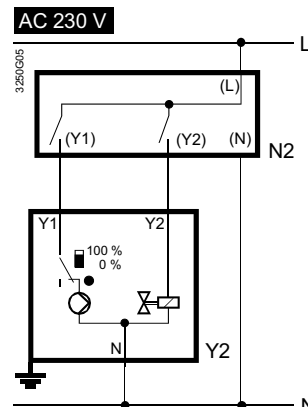

Y1	Positioning signal «open»
Y2	Positioning signal «close»
21	Spring-return function

SKB82..; SKC82..
AC 24 V
3-position

SKB82.51, SKC82.51

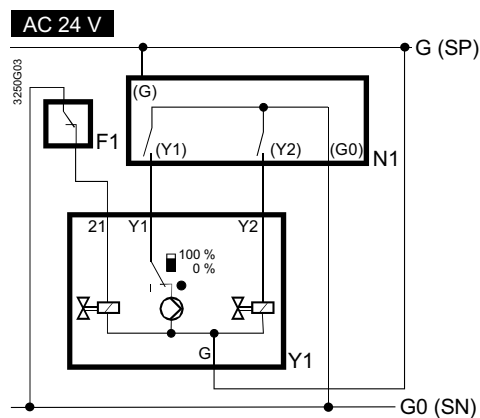

F1	Temperature limiter	SP	Systempotential AC 24 V
N1, N2	Controller	SN	System neutral
Y1, Y2	Actuators		

SKB82.50, SKC82.50

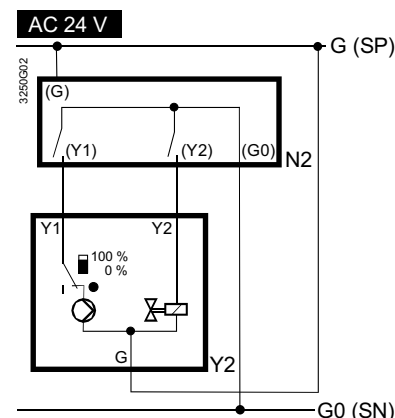

Y1	Positioning signal «open»
Y2	Positioning signal «close»
21	Spring-return function

HLD, HLF HLG, HLI



**Electrohydraulic actuators
SKB 60 and SKB 62...
SKC 60 and SKC 62...
Siemens (Landis & Staefa)**

Technical data

Type	SKB 60	SKB 62	SKB 62UA ^{*)}	SKC 60	SKC 62	SKC 62UA ^{*)}
Mark in valve spec. No.	HLD	HLF		HLG	HLI	
Voltage	24 V AC					
Frequency	50...60 Hz					
Power consumption	13 VA	17 VA		24 VA	28 VA	
Control	0 - 10 V, 4 - 20 mA, 0 - 1000 Ω					
Running time open	120 s			120 s		
Running time closed	15 s			20 s		
Fail-safe action time	---	15 s		---	20 s	
Nominal force	2800 N					
Travel	20 mm			40 mm		
Enclosure	IP 54					
Process medium max.t.	220°C (higher temperature with Bellows only)					
Ambient and actuator's surface temperature range	-15 to 55°C					
Ambient humidity range	0 - 95 % relative humidity					
Weight	8,6 kg			10 kg		

^{*)} UA ... version with improved electronics

Accessories

Auxiliary switch 24 V ASC1.6

Description

Each actuator with continuous control signal is equipped with ACT control technology enabling the following features as standard:

- stroke range calibration
- state indication via LED
- flow characteristic selection (log / lin)
- selection of control signal at Y terminal
- feedback signal at U terminal corresponding to control signal at Y terminal
- forced control at Z terminal

Version with improved electronics (UA) further enables:

- inversion of control signal
- sequence control
- stroke limiting

Dimensions of actuator

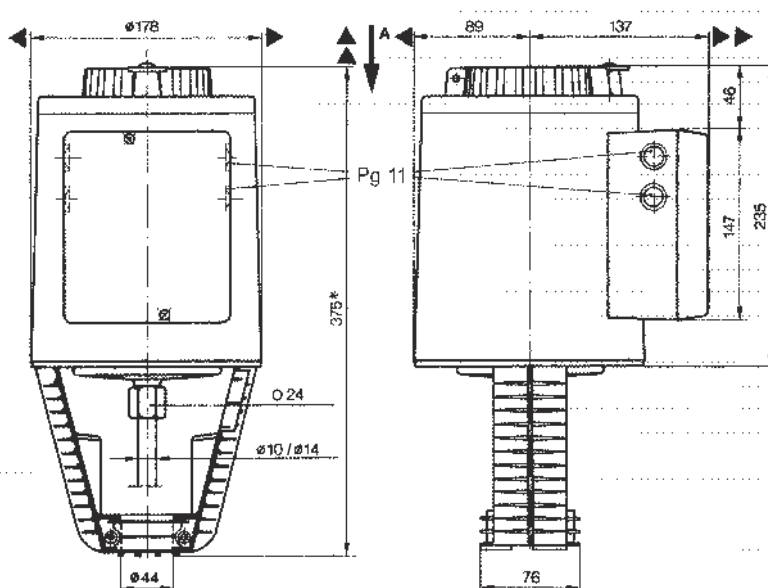

Connection terminals

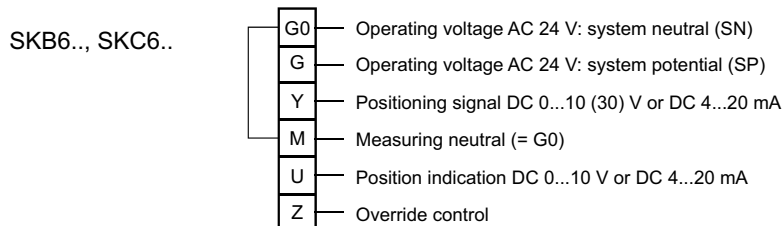

Auxiliary switch ASC1.6

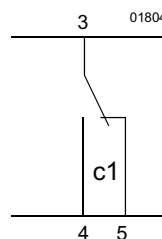

Connection diagrams

SKB6..., SKC6...,
AC 24 V
DC 0...10 V, 4...20 mA,
0...1000 Ω

SKB60
SKC60

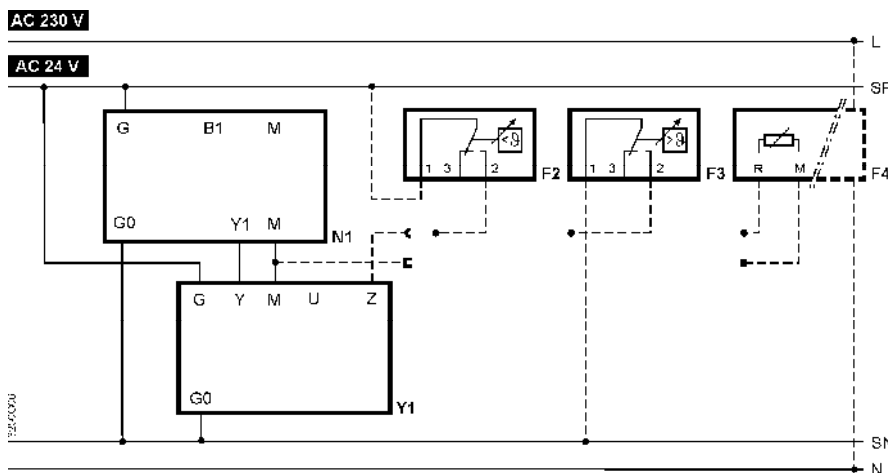

SKB62
SKB62UA
SKC62
SKC62UA

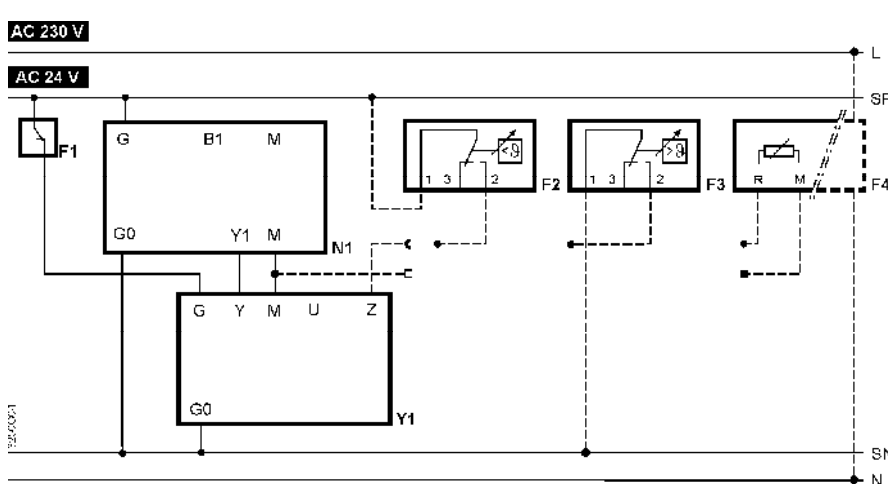

- Y1 Actuator
- N1 Controller
- F1 Temperature limiter
- F2 Frost protection thermostat
 - terminals: 1 – 3 frost hazard / sensor is interrupted (thermostat closes with frost)
 - 1 – 2 normal operation
- F3 Frost protection monitor
- F4 Frost protection monitor QAF21.. or QAF61.. (for SKD62UA only) *
- G (SP) System potential AC 24 V
- G0 (SN) Systémová neutral

* Only with sequence control and the appropriate selector switch settings

Maximal permissible operating pressures acc. to ČSN EN 12516-1, resp. ČSN EN 1092-2 [MPa]

Material	PN	Temperature [°C]													
		RT ¹⁾	100	120	150	200	250	300	350	375	400	425	450	475	500
Brass 42 3135 (CuSn5Zn5Pb5-C)	16	1,60	1,60	1,60	1,14	---	---	---	---	---	---	---	---	---	---
		---	---	---	---	---	---	---	---	---	---	---	---	---	---
Grey cast iron EN-JL 1040 (EN-GJL-250)	16	1,60	1,60	1,60	1,44	1,28	---	---	---	---	---	---	---	---	---
		---	---	---	---	---	---	---	---	---	---	---	---	---	---
Spher.cast iron EN-JS 1025 (EN-GJS-400-18-LT)	16	1,60	1,60	1,60	1,55	1,47	1,39	1,28	1,12	---	---	---	---	---	---
	25	2,50	2,50	2,50	2,43	2,30	2,18	2,00	1,75	---	---	---	---	---	---
	40	4,00	4,00	4,00	3,88	3,68	3,48	3,20	2,80	---	---	---	---	---	---
Cast steel 1.0619 (GP240GH)	16	1,56	1,36	1,32	1,27	1,14	1,04	0,94	0,88	0,86	0,84	---	---	---	---
	25	2,44	2,13	2,07	1,98	1,78	1,62	1,47	1,37	1,35	1,32	---	---	---	---
	40	3,90	3,41	3,31	3,17	2,84	2,60	2,35	2,19	2,16	2,11	---	---	---	---
Chrommolybden steel 1.7357 (G17CrMo5-5)	16	1,63	1,63	1,61	1,58	1,49	1,43	1,33	1,23	1,20	1,15	1,11	1,07	1,00	0,89
	25	2,55	2,54	2,51	2,48	2,33	2,23	2,08	1,93	1,88	1,80	1,73	1,67	1,56	1,39
	40	4,08	4,07	4,02	3,96	3,74	3,57	3,33	3,09	3,00	2,89	2,77	2,67	2,50	2,23
Stainless steel 1.4581 (GX5CrNiMoNb19-11-2)	16	1,59	1,44	1,39	1,33	1,25	1,17	1,10	1,06	1,05	1,02	1,02	1,01	1,00	0,89
	25	2,49	2,25	2,18	2,08	1,95	1,84	1,72	1,66	1,63	1,60	1,59	1,58	1,56	1,39
	40	3,98	3,60	3,49	3,33	3,13	2,94	2,75	2,65	2,61	2,56	2,54	2,52	2,50	2,23
Stainless steel 1.4308 (GX5CrNi19-10)	16	1,52	1,17	1,12	1,06	0,96	0,89	0,83	0,79	0,77	0,74	0,74	0,72	0,71	0,70
	25	2,37	1,84	1,76	1,66	1,50	1,40	1,30	1,23	1,20	1,16	1,15	1,13	1,11	1,09
	40	3,79	2,94	2,82	2,65	2,41	2,24	2,08	1,97	1,91	1,86	1,84	1,80	1,78	1,74

¹⁾ -10°C až 50°C



LDM, spol. s r.o.
Litomyšlská 1378
560 02 Česká Třebová
Czech Republic

tel.: +420 465 502 511
fax: +420 465 533 101
E-mail: sale@ldm.cz
<http://www.ldm.cz>

LDM, spol. s r.o.
Office in Prague
Podolská 50
147 01 Praha 4
Czech Republic

tel.: +420 241 087 360
fax: +420 241 087 192

LDM, spol. s r.o.
Office in Ústí nad Labem
Mezní 4
400 11 Ústí nad Labem
Czech Republic

tel.: +420 475 650 260
fax: +420 475 650 263

LDM servis, spol. s r.o.
Litomyšlská 1378
560 02 Česká Třebová
Czech Republic

tel.: +420 465 502 411-3
fax: +420 465 531 010
E-mail: servis@ldm.cz

LDM, Polska Sp. z o.o.
Modelarska 12
40 142 Katowice
Poland

tel.: +48 32 730 56 33
fax: +48 32 730 52 33
mobile: +48 601 354 999
E-mail: ldmpolska@ldm.cz

LDM Bratislava s.r.o.
Mierová 151
821 05 Bratislava
Slovakia

tel.: +421 2 43415027-8
fax: +421 2 43415029
E-mail: ldm@ldm.sk
<http://www.ldm.sk>

LDM - Bulgaria - OOD
z. k. Mladost 1
bl. 42, floor 12, app. 57
1784 Sofia
Bulgaria

tel.: +359 2 9746311
fax: +359 2 9746311
GSM: +359 888 925 766
E-mail: ldm.bg@ldmvalves.com

OOO "LDM Promarmatura"
Moskovskaya street,
h. 21, Office No. 520
141400 Khimki
Russian Federation

tel.: +7 495 777 22 38
fax: +7 495 777 22 38
E-mail: inforus@ldmvalves.com

TOO "LDM"
Lobody 46/2
Office No. 4
100008 Karaganda
Kazakhstan

tel.: +7 7212 566 936
fax: +7 7212 566 936
mobile: +7 701 738 36 79
E-mail: sale@ldm.kz
<http://www.ldm.kz>

LDM Armaturen GmbH
Wupperweg 21
D-51789 Lindlar
Germany

tel.: +49 2266 440333
fax: +49 2266 440372
mobile: +49 177 2960469
E-mail: ldmarmaturen@ldmvalves.com
<http://www.ldmvalves.com>

Your partner