

01 - 02.1

01.11.GB

**LDM valves
with electromechanic actuators**

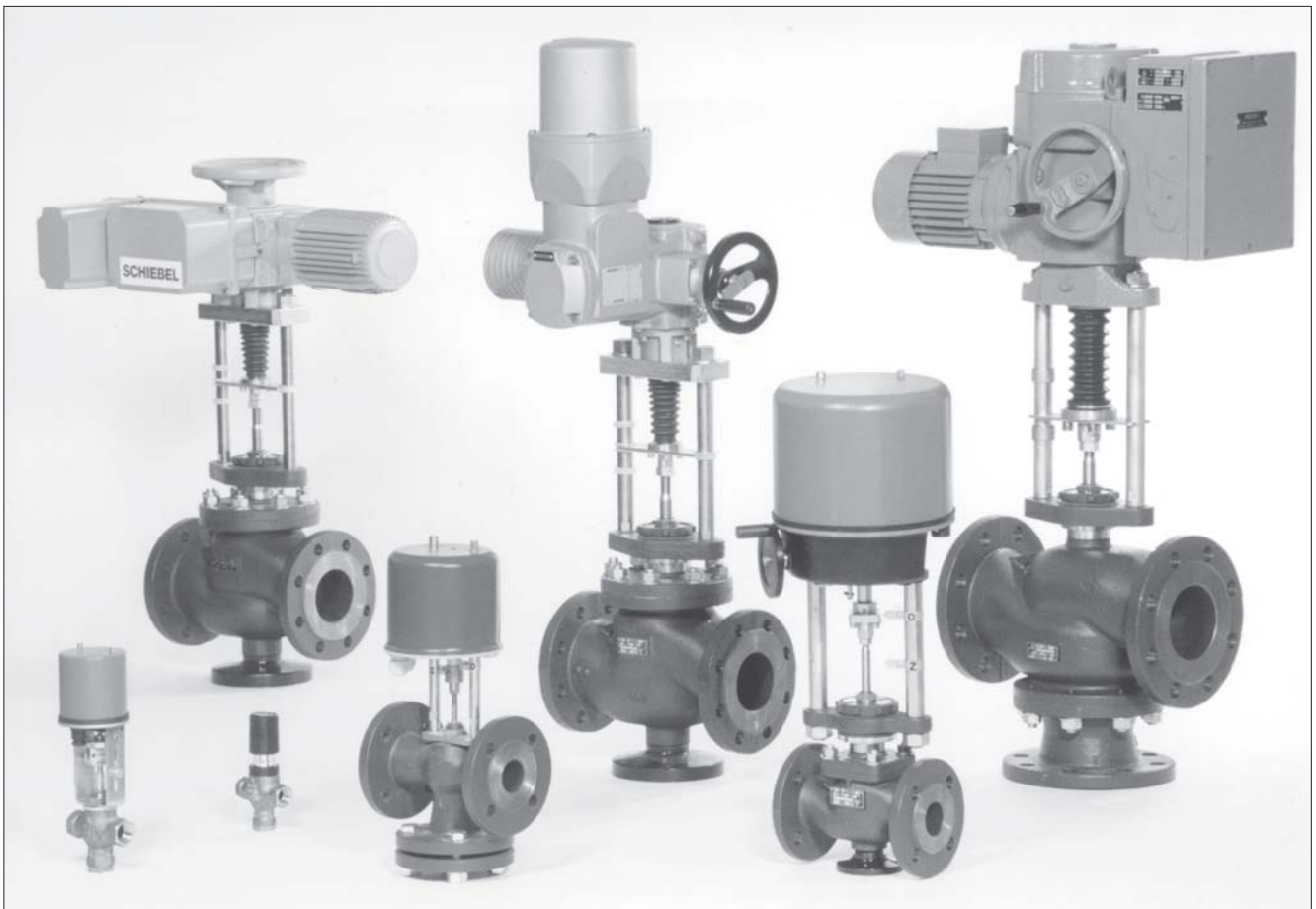

Kv coefficient calculation

Calculation itself is carried out with respect to conditions of regulating circuit and operating medium according to equations mentioned below. Control valve must be designed to be able to regulate maximal flow quantity at given operating conditions. At the same time it is necessary to check whether minimal flow quantity can be even regulated or not.

Condition is the following ratio $r > Kvs / Kv_{min}$

Because of eventual minus tolerance 10% of Kv_{100} against Kvs and requirement for possible regulation within range of maximal flow (decrement and increase of flow), producer recommends to select Kvs value higher than maximal operating Kv value:

$$Kvs = 1.1 \div 1.3 Kv$$

It is necessary to take into account to which extent Q_{max} involve "precautionary additions" that could result in valve oversizing.

Relations of Kv calculation

		Pressure drop $p_2 > p_1/2$ $\Delta p < p_1/2$	Pressure drop $\Delta p \geq p_1/2$ $p_2 \leq p_1/2$
Kv =	Liquid	$\frac{Q}{100} \sqrt{\frac{\rho_1}{\Delta p}}$	
	Gas	$\frac{Q_n}{5141} \sqrt{\frac{\rho_n \cdot T_1}{\Delta p \cdot p_2}}$	$\frac{2 \cdot Q_n}{5141 \cdot p_1} \sqrt{\rho_n \cdot T_1}$
	Superh. steam	$\frac{Q_m}{100} \sqrt{\frac{v_2}{\Delta p}}$	$\frac{Q_m}{100} \sqrt{\frac{2v}{p_1}}$
	Sat. steam	$\frac{Q_m}{100} \sqrt{\frac{v_2 \cdot x}{\Delta p}}$	$\frac{Q_m}{100} \sqrt{\frac{2v \cdot x}{p_1}}$

Above critical flow of vapours and gases

When pressure ratio is above critical ($p_2 / p_1 < 0.54$), speed of flow reaches acoustic velocity at the narrowest section. This event can cause higher level of noisiness. Then it is convenient to use a throttling system ensuring low noisiness (multi-step pressure reduction, damping orifice plate at outlet).

Dimensions and units

Marking	Unit	Name of dimension
Kv	$m^3 \cdot h^{-1}$	Flow coefficient under condition of units of flow
Kv_{100}	$m^3 \cdot h^{-1}$	Flow coefficient at nominal stroke
Kv_{min}	$m^3 \cdot h^{-1}$	Flow coefficient at minimal flow rate
Kvs	$m^3 \cdot h^{-1}$	Valve nominal flow coefficient
Q	$m^3 \cdot h^{-1}$	Flow rate in operating conditions (T_1, p_1)
Q_n	$Nm^3 \cdot h^{-1}$	Flow rate in normal conditions (0°C, 0.101 Mpa)
Q_m	$kg \cdot h^{-1}$	Flow rate in operating conditions (T_1, p_1)
p_1	MPa	Upstream absolute pressure
p_2	MPa	Downstream absolute pressure
p_s	MPa	Absolute pressure of saturated steam at given temperature (T_1)
Δp	MPa	Valve differential pressure ($\Delta p = p_1 - p_2$)
ρ_1	$kg \cdot m^{-3}$	Process medium density in operating conditions (T_1, p_1)
ρ_n	$kg \cdot Nm^{-3}$	Gas density in normal conditions (0°C, 0.101 Mpa)
v_2	$m^3 \cdot kg^{-1}$	Specific volume of steam when temperature T_1 and pressure p_2
v	$m^3 \cdot kg^{-1}$	Specific volume of steam when temperature T_1 and pressure $p_1/2$
T_1	K	Absolute temperature at valve inlet ($T_1 = 273 + t_1$)
x	1	Proportionate weight volume of saturated steam in wet steam
r	1	Rangeability

Flow characteristic selection in regard of valve stroke

To make right selection of valve flow characteristic, it is suitable to carry out checking of what stroke values will be reached in different operation states. We recommend to carry out such checking at least for minimal, nominal and maximal flow rates. The principle for flow characteristic selection is to avoid, if possible, 5÷10% of the beginning and end of the valve stroke range.

To calculate valve stroke at different operating conditions with different types of flow characteristics is possible with the advantage of using LDM's calculation programme VALVES. The programme serves for complete design of valve from Kv calculation to specification of a concrete valve with its actuator.

Valve flow characteristics

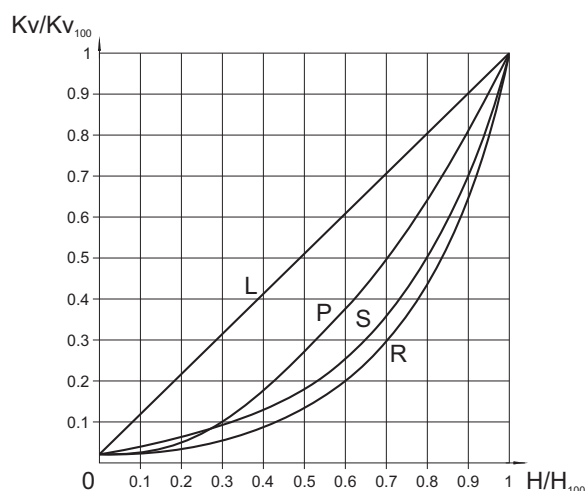

L - linear characteristic

$$Kv/Kv_{100} = 0.0183 + 0.9817 \cdot (H/H_{100})$$

R - equal-percentage characteristic (4-percentage)

$$Kv/Kv_{100} = 0.0183 \cdot e^{(4 \cdot H/H_{100})}$$

P - parabolic characteristic

$$Kv/Kv_{100} = 0.0183 + 0.9817 \cdot (H/H_{100})^2$$

S - LDM spline[®] characteristic

$$Kv/Kv_{100} = 0.0183 + 0.269 \cdot (H/H_{100}) - 0.380 \cdot (H/H_{100})^2 + 1.096 \cdot (H/H_{100})^3 - 0.194 \cdot (H/H_{100})^4 - 0.265 \cdot (H/H_{100})^5 + 0.443 \cdot (H/H_{100})^6$$

Principles for plug type selection

V-ported plugs should not be used in above - critical differential pressures with inlet pressure $p_1 \geq 0,4$ MPa and for regulation of saturated steam. In these cases we recommend to use a perforated plug. The perforated plug should be also used always when cavitation may occur due to a high differential pressure value or valve ports erosion caused by high speed of process medium flow. If the parabolic plug is used (because of small Kvs) for above-critical differential pressures, it is necessary to close both plug and seat with a hard metal overlay, i.e. stellite trim.

Packing - O-ring EPDM

Packing is designed for non-aggressive media with temperature from 0°C to 140°C. Packing excels with its reliability and long time tightness. It has ability of sealing even if the valve stem is a bit damaged. Low frictional forces enables valve to be actuated with a low-linear-force actuator. Service life of sealing rings depends on operating conditions and it is more than 400 000 cycles on average.

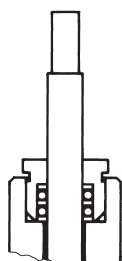

Applied to RV 102, RV 103

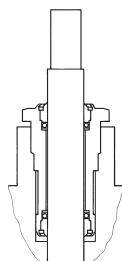

Applied to RV 2xx

Packing - DRSpack® (PTFE)

DRSpack® (Direct Radial Sealing Pack) is a packing with high tightness at both low and high operating pressure values.

It is the most used type of packing suitable for temperatures ranging from 0°C to 260°C. The pH range is from 0 to 14. The packing enables using of actuators with low linear force. The design enables an easy change of the whole packing. The average service life of DRSpack® is more than 500 000 cycles.

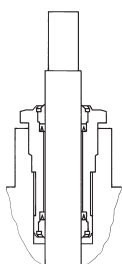

Packing - Graphite

This type of packing can be used for media with temperature up to 550°C and pH range: 0 to 14. Packing can be "sealed up" either by screwing the packing screw in or adding another sealing ring. In regard of intensive frictional forces, graphite packing is suitable for actuators with a sufficient linear force.

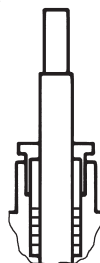

Packing - Bellows

Bellows packing is suitable for low and high temperatures ranging from -50°C to 550°C. Bellows ensures absolute tightness to environment. Packing is equipped with safety PTFE packing as standard to prevent medium from leaking in case of damage to bellows. Intensive linear forces are not required.

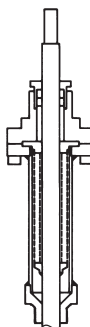

Application of bellows packing

Bellows packing is suitable for applications with very aggressive, toxic or other dangerous media that require absolute tightness to environment. In such case, it is necessary to check compatibility of used body material as well as the valve inner parts material with process medium. It is recommended to use bellows with safety packing preventing medium from leaking in case of damage to bellows when there is an extremely dangerous process medium used.

Bellows is also a great solution to use of process medium either with temperature below zero when ice accretions cause premature damage to packing or with high temperatures when bellows ensures medium cooling.

Rangeability

Rangeability is the ratio of the biggest value of flow coefficient to the smallest value. In fact it is the ratio (under the same conditions) of highest regulated flow rate value to its lowest value. The lowest or minimal regulated flow rate is always higher than 0.

Service life of bellows packing

Bellows material	Temperature				
	200°C	300°C	400°C	500°C	550°C
1.4541	100 000	40 000	28 000	7 000	not applicable
1.4571	90 000	34 000	22 000	13 000	8 000

Values specified in the table above show minimal guaranteed number of cycles with the valve full stroke when the bellows is fully lengthened and pressed. In regulation, when the valve

moves only in a portion of the stroke range at the inner centre of the valve, the service life of the bellows is many times longer then depending on concrete operating conditions.

Procedure for designing of two-way valve

Given: medium water, 155°C, static pressure at piping spot 1000 kPa (10 bar), $\Delta p_{DISP} = 80$ kPa (0,8 bar), $\Delta p_{PIPELINE} = 15$ kPa (0,15 bar), $\Delta p_{APPLIANCE} = 25$ kPa (0,25 bar), nominal flow rate $Q_{NOM} = 8$ m³·h⁻¹, minimal flow rate $Q_{MIN} = 1,3$ m³·h⁻¹.

$$\Delta p_{DISP} = \Delta p_{VALVE} + \Delta p_{APPLIANCE} + \Delta p_{PIPELINE}$$

$$\Delta p_{VALVE} = \Delta p_{DISP} - \Delta p_{APPLIANCE} - \Delta p_{PIPELINE} = 80 - 25 - 15 = 40 \text{ kPa (0,4 bar)}$$

$$Kv = \frac{Q_{NOM}}{\sqrt{\Delta p_{VALVE}}} = \frac{8}{\sqrt{0,4}} = 12,7 \text{ m}^3 \cdot \text{h}^{-1}$$

Precautionary additions for process tolerances (provided that flow rate Q was not oversized):

$$Kvs = (1,1 \text{ to } 1,3) \cdot Kv = (1,1 \text{ to } 1,3) \cdot 12,7 = 14 \text{ to } 16,5 \text{ m}^3 \cdot \text{h}^{-1}$$

Now we choose the nearest Kvs value from those available in our catalogue, i.e. $Kvs = 16$ m³·h⁻¹. This value corresponds to nominal size of DN 32. Then if we choose flanged execution PN 16, body made of spheroidal cast iron, with metal - PTFE seat sealing, packing PTFE and equal-percentage flow characteristic, we will get the following specification No.:

RV 21x XXX 1423 R1 16/220-32

x in the valve code above (21x) stands for valve execution (direct or reverse) and depends on type of used actuator which should be chosen in respect to demands of regulating system (type, producer, voltage, type of control, necessary torque or linear force, etc.).

Determination of real pressure drop value of a chosen valve at fully open

$$\Delta p_{VALVE H100} = \left(\frac{Q_{NOM}}{Kvs} \right)^2 = \left(\frac{8}{16} \right)^2 = 0,25 \text{ bar (25 kPa)}$$

The control valve's real pressure drop calculated this way shall be taken into account in a hydraulic calculation of regulating circuit.

Determination of valve's real authority

$$a = \frac{\Delta p_{VALVE H100}}{\Delta p_{VALVE H0}} = \frac{25}{80} = 0,31$$

Value a should be at least equal to 0,3. A chosen valve checking is then satisfactory.

Caution: the valve's authority calculation should be related to a valve pressure difference in its closed position i.e. disposition pressure value in a branch Δp_{AVAIL} when flow rate is zero, not to a pressure value of a pump Δp_{PUMP} , because, due to pipeline circuit pressure drops up to the spot where the regulating branch is connected, the following equation applies: $\Delta p_{AVAIL} < \Delta p_{PUMP}$. In such cases we consider for simplicity the following: $\Delta p_{AVAIL H100} = \Delta p_{AVAIL H0} = \Delta p_{DISP}$.

Checking of rangeability

We carry out the same checking for minimal flow rate $Q_{MIN} = 1,3$ m³·h⁻¹. The following differential pressure values correspond to the min. flow rate: $\Delta p_{APPLIANCE QMIN} = 0,40$ kPa, $\Delta p_{PIPELINE QMIN} = 0,66$ kPa. $\Delta p_{VALVE QMIN} = 80 - 0,4 - 0,66 = 78,94 = 79$ kPa.

$$Kv_{MIN} = \frac{Q_{MIN}}{\sqrt{\Delta p_{VALVE QMIN}}} = \frac{1,3}{\sqrt{0,79}} = 1,46 \text{ m}^3 \cdot \text{h}^{-1}$$

Necessary rangeability value

$$r = \frac{Kvs}{Kv_{MIN}} = \frac{16}{1,46} = 11$$

shall be lower than mentioned rangeability value of $r = 50$. Checking is then satisfactory.

Selection of suitable flow characteristic

On the basis of calculated values Kv_{NOM} and Kv_{MIN} , it is possible to read the appropriate stroke values from the graph for individual types of flow characteristics of the valve and choose the most suitable one accordingly. Here we have $h_{NOM} = 96\%$, $h_{MIN} = 41\%$ for equal-percentage characteristic. In that case, LDMspline® flow characteristic is more suitable (93% and 30% of the stroke). It corresponds to the following specification code :

RV 21x XXX 1423 S1 16/220-32

Scheme of typical regulation loop with the application of two-way control valve

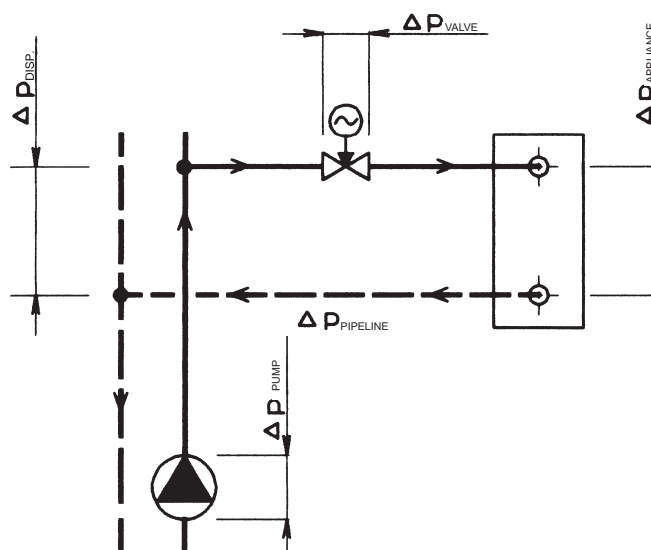

Remark: More detailed information on calculation and design of LDM control valves is mentioned in calculation instructions No. 01-12.0. Equations mentioned above apply in a simplified way to water. To reach optimum results, we recommend to use original calculation programme VALVES which is available on request free of charge.

Procedure for designing of three-way valve

Given: medium water, 90°C, static pressure at piping spot 1000 kPa (10 bar), $\Delta p_{\text{PUMP2}} = 40 \text{ kPa}$ (0,4 bar), $\Delta p_{\text{PIPELINE}} = 10 \text{ kPa}$ (0,1bar), $\Delta p_{\text{APPLIANCE}} = 20 \text{ kPa}$ (0,2 bar), flow rate $Q_{\text{NOM}} = 7 \text{ m}^3 \cdot \text{h}^{-1}$

$$\Delta p_{\text{PUMP2}} = \Delta p_{\text{VALVE}} + \Delta p_{\text{APPLIANCE}} + \Delta p_{\text{PIPELINE}}$$

$$\Delta p_{\text{VALVE}} = \Delta p_{\text{PUMP2}} - \Delta p_{\text{APPLIANCE}} - \Delta p_{\text{PIPELINE}} = 40 - 20 - 10 = 10 \text{ kPa} (0,1\text{bar})$$

$$Kv = \frac{Q_{\text{NOM}}}{\sqrt{\Delta p_{\text{VALVE}}}} = \frac{7}{\sqrt{0,1}} = 22,1 \text{ m}^3 \cdot \text{h}^{-1}$$

Precautionary additions for process tolerances (provided that flow rate Q was not oversized):

$$Kvs = (1,1 \text{ to } 1,3) \cdot Kv = (1,1 \text{ to } 1,3) \cdot 22,1 = 24,3 \text{ to } 28,7 \text{ m}^3 \cdot \text{h}^{-1}$$

Now we choose the nearest Kvs value from those available in our catalogue, i.e. $Kvs = 25 \text{ m}^3 \cdot \text{h}^{-1}$. This value corresponds to nominal size of DN 40. Then if we choose flanged execution PN 16, body made of spheroidal cast iron, with metal - PTFE seat sealing, packing PTFE and equal-percentage flow characteristic, we will get the following specification No.:

RV 21x XXX 1413 L1 16/140-40

x in the valve code above (21x) stands for valve execution (direct or reverse) and depends on type of used actuator which should be chosen in respect to demands of regulating system (type, producer, voltage, type of control, necessary torque or linear force, etc.)

Determination of real pressure drop value of a chosen valve at fully open

$$\Delta p_{\text{VALVE H100}} = \left(\frac{Q_{\text{NOM}}}{Kvs} \right)^2 = \left(\frac{7}{25} \right)^2 = 0,08 \text{ bar} (8 \text{ kPa})$$

The control valve's real pressure drop calculated this way shall be taken into account in a hydraulic calculation of regulating circuit.

Caution: To ensure reliable function of three-way valves, the most important condition is to keep minimum available pressure difference between A and B ports. Three-way valves are capable to manage even high pressure difference between A and B ports but valve's flow characteristic deformats then and so regulation properties deteriorate. So if in doubt about pressure difference value between those two ports (e.g. when three-way valve is piped directly into primary side without pressure separation), we recommend to use a two-way valve in combination with a primary-secondary side short cut to ensure a reliable regulation. The authority of A-AB way of three-way valve is, providing a constant flow rate in appliance circuit, the following:

$$a = \frac{\Delta p_{\text{VALVE H100}}}{\Delta p_{\text{VALVE H0}}} = \frac{8}{8} = 1 ,$$

which means that the behaviour of flow in A-AB way corresponds to ideal flow curve of the valve. In that case there are Kvs values in both ports the same with linear characteristic i.e. the total flow is nearly constant.

A combination of equal-percentage characteristic in A port and linear characteristic in B port shall be selected in those cases when loading of A port with differential pressure against B port cannot be avoided or when the primary side parametres are too high.

Scheme of a typical regulation loop with the application of a three-way mixing control valve

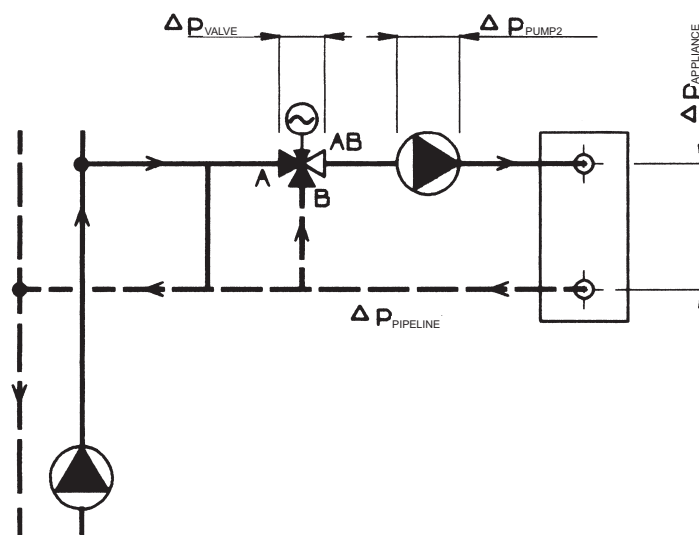

Remark: More detailed information on calculation and design of LDM control valves is mentioned in calculation instructions No. 01-12.0. Equations mentioned above apply in a simplified way to water. To reach optimum results, we recommend to use original calculation programme VALVES which is available on request free of charge.

RV 102 E RV 103 E



Control valves DN 15 - 50, PN 16 with electromechanic actuators

Description

Control valves series RV 102 are two-way or three-way valves with internal threaded connection. Valve body is made of brass. Control valves series RV 103 are two-way or three-way valves with flanged connection. Valve body is made of grey cast iron. Valves are optionally manufactured in the following executions:

- three-way control valve
- two-way, reverse, control valve
- two-way, angular, control valve

Valves RV 102 E and RV 103 E are equipped with hand wheel or they are especially designed for actuators of the following producers: Ekorex+ and ZPA Nová Paka.

Application

Valves are designed for application in heating, ventilation or air conditioning systems for maximal temperature 150° C. Maximal permissible operating pressures acc. to ČSN 13 0010, see page 75 of this catalogue.

Process media

Valve series RV 102 and RV 103 are designed to regulate the flow and pressure of liquids, gases and vapours without abrasive particles e.g. water, low-pressure steam, (it applies to RV 102 only), air and other media compatible with material of the valve inner parts. Medium acidity and alkalinity should not exceed range of pH 4.5 to 9.5.

To ensure reliable regulation, producer recommends to pipe a strainer in front of the valve into pipeline.

The valve cannot work in cavitation conditions. RV 103 valves are not suitable for steam and steam condensate.

Installation

The valve is to be piped the way so that the direction of medium flow will coincide with the arrows on the body (inlet ports A, B and outlet port AB).

In flow-diverting valves, the process medium flow is reversed (inlet port AB and outlet ports A, B).

Valve can be installed in any position except position when the actuator is under the valve body.

Technical data

Series	RV 102	RV 103
Type of valve	Three-way control valve Two-way, reverse, control valve	
Nominal size range	DN 15 - 50	
Nominal pressure	PN 16	
Body material	Brass 42 3135	Grey cast iron EN-JL 1040
Plug material	Brass 42 3234	
Operating temperature range	0 - 150°C	
Face to face dimensions	Section M4 Acc. to DIN 3202 (4/1982)	Section 1 acc. to ČSN-EN 558-1 (3/1997)
Connection	Internal threaded coupling acc. to ČSN-EN ISO 228-1 (9/2003)	Flange type B1 (raised face) acc. to ČSN-EN 1092-1 (4/2002)
Type of plug	V-ported plug	
Flow characteristic	Linear; equal-percentage, in direct way	
Kvs values	0.6 to 40 m ³ /hour	
Leakage rate	Class III. acc. to ČSN-EN 1349 (5/2001) (< 0.1% Kvs) in A-AB way	
Rangeability r	50 : 1	
Packing	O - ring EPDM	

Kvs values and differential pressures

Δp_{max} value is the valve maximal differential pressure when reliable opening and closing can be guaranteed. Because of seat and plug service life, it is recommended so that

permanent differential pressure would not exceed 0.6 MPa for valves RV 102 and 0.4 MPa for valves RV 103.

For further information on actuating, see actuators' catalogue sheets

		Actuating (actuator)					Hand wheel	PIKO 524 65	PTE1	PTN1 MIKRO 655	PTN1	MIKRO 655	PTN2.20
		Marking in valve spec. No.					R	END	ERE	ERA, ENA	ERA	ENA	ERB
		Linear force						250 N	500 N	600 N	1200 N	1800 N	2000 N
		Kvs [m ³ /hour]					Δp_{max}	Δp_{max}	Δp_{max}	Δp_{max}	Δp_{max}	Δp_{max}	Δp_{max}
DN	H	1	2	3	4	5	MPa	MPa	MPa	MPa	MPa	MPa	
15	10	4.0	2.5	1.6	1.0	0.6	1.60	0.81	1.60	1.60	1.60	1.60	
20		6.3	4.0	2.5	---	---	1.10	0.45	1.07	1.32	1.60	1.60	
25		10.0	6.3	4.0	---	---	0.70	0.28	0.69	0.85	1.60	1.60	
32	16	16.0	10.0	6.3	---	---	0.45	0.16	0.42	0.52	1.14	1.60	
40		25.0	16.0	10.0	---	---	0.28	0.10	0.27	0.33	0.74	1.15	
50		40.0	25.0	16.0	---	---	0.16	0.05	0.15	0.19	0.44	0.69	

Dimensions and weights for the type RV 102

DN	C	L ₁	L ₂	L ₃	V ₁	V ₂	S	H	D	m
		mm	mm	mm	mm	mm	mm	mm	mm	kg
15	G 1/2	85	9	12	43	25	27	10	M8x1	0.55
20	G 3/4	95	11	14	48	25	32			0.65
25	G 1	105	12	16	53	25	41			0.80
32	G 1 1/4	120	14	18	66	35	50	16	M8x1	1.40
40	G 1 1/2	130	16	20	70	35	58			2.00
50	G 2	150	18	22	80	42	70			2.95

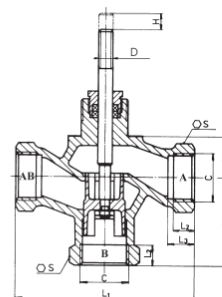

Dimensions and weights for the type RV 103

DN	D ₁	D ₂	D ₃	n x d	a	f	L ₁	V ₁	V ₂	H	D	MIX 2-cest	
												m	m
	mm	mm	mm	mm	mm	mm	mm	mm	mm	mm	mm	kg	kg
15	95	65	45	4x14	16	2	130	65	25	10	M8x1	3.2	4.0
20	105	75	58		150		75	25	4.3			5.4	
25	115	85	68		160		80	25	5.5			6.8	
32	140	100	78	4x18	18	3	180	90	35	16	M8x1	7.7	9.7
40	150	110	88		200		100	35	8.5			10.9	
50	165	125	102		230		115	42	11.9			15.6	

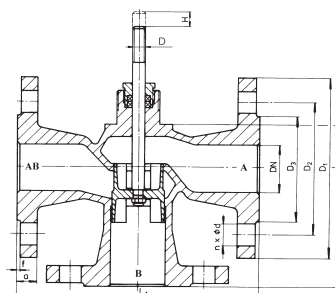

Valve complete specification No. for ordering

	XX	X X X	X X X	X X	X X	X X	- XX	/	XXX	- XX	
1. Type of valve	Control valve	RV									
2. Series	Valves made of brass		1 0 2								
	Valves made of grey cast iron		1 0 3								
3. Actuating	Electric actuator						E				
	Hand wheel						R				
							-				
	Electric actuator PTN1						E R A				
	Electric actuator PTN2.20						E R B				
	Electric actuator PTE1						E R E				
	Electric actuator MIKRO 655						E N A				
	Electric actuator PIKO 524 64						E N D				
4. Design	Straight, two-way, threaded valves								1		
	Angle, two-way, threaded valves								2		
	Mixing (diverting), three-way, threaded valves								3		
	Straight, two-way, flanged valves								4		
	Angle, two-way, flanged valves								5		
	Mixing (diverting), three-way, flanged valves								6		
5. Body material	Grey cast iron								3		
	Brass								5		
6. Flow characteristic	Linear								1		
	Equal-percentage, in direct way								2		
7. Nominal Kvs value	Column No. acc. to Kvs values table								X		
8. Nominal pressure PN	PN 16										
9. Max. operating temperature °C										16	
10. Nominal size	DN										150
											XX

Ordering example: Three-way control valve DN 25, PN 16, with electric actuator PIKO 524 65, body material: brass, connection: with internal thread G 1, linear flow characteristic, Kvs = 10 m³/hour is specified as follows:

RV 102 END 3511 16/150-25.

RV / UV 2x0 E (Ex)

Control and Shut-off valves DN 15 - 400, PN 16, 25 and 40 with electromechanic actuators



Description

Control valves RV / UV 210 (Ex), RV / UV 220 (Ex) and RV / UV 230 (Ex) [(further only RV / UV 2x0 (Ex))] are single-seated valves designed for regulation and shut-off of process medium flow. In regard of a great variety of used actuators, the valves are suitable for regulation at low as well as high differential pressures in a diversity of operating conditions. Flow characteristics, Kvs values and leakage rates correspond to international standards. Valves RV / UV 2x0 (Ex) are equipped with hand wheel or are especially designed for electro-mechanic actuators of the following producers: Ekorex+, ZPA Nová Paka, Regada, ZPA Pečky, Schiebel, Auma, Drehmo and Rotork.

Application

The valves series RV / UV 2x0 are designed for applications in heating, ventilation, power generation and chemical processing industries. The valves RV / UV 2x0 Ex meet the requirements II 1/2G IIB dle ČSN-EN 13463-1 (9/2002) and ČSN EN 1127-1 (9/1998), and in connection with suitable actuators, they are also designed for applications in gas and chemical industries. Valve body can be optionally made of spheroidal cast iron, cast steel and stainless steel.

The materials selected correspond to recommendations stipulated by ČSN-EN 1503-1 (1/2002) (steels) and ČSN-EN 1503-3 (1/2002) (cast). The maximal permissible operating pressures in behaviour with types of material and temperature are specified in the table on page 75 of this catalogue.

Process media

Valves series RV (UV) 2x0 are designed for regulation (RV 2x0) and shut-off (UV 2x0) of flow and pressure of liquids, gases and vapours without abrasive particles e.g. water, steam, air and other media compatible with material of the valve inner parts. The valves series RV / UV 2x0 Ex are also designed for control and shut-off of the flow and pressure of technical and fuel gases and inflammable liquids. The usage of the valve made of spheroidal cast iron (RV 210) for steam is limited by the following parameters. The steam must be superheated (its dryness at valve outlet x_1 0,98) and inlet pressure p_1 0,4 MPa when differential pressure is of above-critical value, and p_1 1,6 MPa when differential pressure is of under-critical value. In case these two conditions are not kept, it is necessary to use the valve made of cast steel (RV 220). To ensure a reliable regulation, the producers recommends to pipe a strainer in front of the valve into pipeline or ensure in any other way that process medium does not contain abrasive particles or impurities.

Installation

The valve is to be piped the way so that the direction of medium flow will coincide with the arrows on the body.

The valve can be installed in any position except position when the actuator is under the valve body.

Detailed informations are given in the instruction for installation and service.

Technical data

Series	RV / UV 210 (Ex)	RV / UV 220 (Ex)	RV / UV 230 (Ex)
Type of valve	Two-way, single-seated, control (shut-off) valve		
Nominal size range	DN 15 to 400		DN 15 to 400
Nominal pressure	DN 15-150: PN16;40, DN 200-400: PN16		PN 16, 25, 40
Body material	Spheroidal cast iron EN-JS 1018 (EN-GJS-400-10-LT)	Cast steel 1.0619 (GP240GH) 1.7357 (G17CrMo5-5)	Stainless steel 1.4581 (GX5CrNiMoNb19-11-2)
Seat material : DN 15 - 50	1.4028 / 17 023.6	1.4028 / 17 023.6	1.4571 / 17 347.4
DIN W.Nr./+ČSN DN 65 - 400	1.4027 / 42 2906.5	1.4027 / 42 2906.5	1.4581 / 42 2941.4
Plug material : DN 15 - 65	1.4021 / 17 027.6	1.4021 / 17 027.6	1.4571 / 17 347.4
DIN W.Nr./+ČSN DN 80 - 150	1.4027 / 42 2906.5	1.4027 / 42 2906.5	1.4581 / 42 2941.4
DN 200 - 400	1.4021 / 17 022.6	1.4027 / 17 022.6	1.4581 / 42 2941.4
Operating temperature range	-20 to 300°C	-20 to 500°C	-20 to 400°C
Face to face dimensions	Section 1 acc. to ČSN-EN 558-1 (3/1997)		
Connection flanges	Acc. to ČSN-EN 1092-1 (1/1999)	Acc. to ČSN-EN 1092-1 (2/2003)	
Flange faces	Type B1 (raised-faced) acc. to ČSN-EN 1092-1 (1/1999)	Type B1 (raised-faced) or Type F (female) or Type D (groove) acc. to ČSN-EN 1092-1 (2/2003)	
Type of plug	V-ported, contoured, perforated		
Flow characteristic	Linear, equal-percentage, LDMspline®, parabolic, on - off		
Kvs value	0.01 to 1600 m ³ /hour		
Leakage rate	Class III. acc. to ČSN-EN 1349 (5/2001) (<0.1% Kvs) for c. valves with metal-metal seat sealing Class IV. acc. to ČSN-EN 1349 (5/2001) (<0.01% Kvs) for c. valves with metal-PTFE seat sealing Class IV. acc. to ČSN-EN 1349 (5/2001) (<0.01% Kvs) for shut off valve		
Leakage rate for Ex version	Leakage rate 6 acc. to ČSN 13 3060 - section 2		
Rangeability r	50 : 1		
Packing	O - ring EPDM t_{max} =140°C, DRSpack® (PTFE) t_{max} =260°C, Exp. graphite, bellows t_{max} =500°C		

Kvs values and differential pressures of valves [MPa] DN 15 - 150

Δp_{max} value is the valve max. differential pressure when open - close function is always guaranteed. In regard of service life of seat and plug, it is recommended so that

differential pressure would not exceed 1.6 MPa. Otherwise it is suitable to use perforated plug or sealing surfaces of seat and plug with a hard metal overlay.

For further information on actuating, see actuators' catalogue sheets		Actuating (actuator)									PTN 2.20 MIDI 660	ST 0	PTN 2.32 MIDI 660	MIDI 660 ST 0 ST 0.1 PTN 2.40	AUMA Schiebel Rotork EMG	Zepadyn ST 1 Ex ST 0.1 PTN 6
		Marking in valve specification No.									ERB ENB	EPK	ERC ENB	ENB EPK EPL ERC	EA..., EZ..., EQ..., ED...	ENC EPJ EPL ERD
		Linear force									2 kN	2,5 kN	3,2 kN	4,0 kN	5 kN	6,3 kN
DN	H	Kvs [m ³ /hour]									Δp_{max}	Δp_{max}	Δp_{max}	Δp_{max}	Δp_{max}	Δp_{max}
		1	2	3	4	5	6	7	8	9	metal PTFE	metal PTFE	metal PTFE	metal PTFE	metal PTFE	metal PTFE
15	16	---	2.5 ¹⁾	1.6 ¹⁾	1.0 ¹⁾	0.6 ¹⁾	0.4 ¹⁾	0.25 ¹⁾	0.16 ³⁾	0.1 ³⁾	4.00 ---	4.00 ---	4.00 ---	4.00 ---	4.00 ---	4.00 ---
15		4.0 ¹⁾	---	---	---	---	---	---	---	---	4.00 ---	4.00 ---	4.00 ---	4.00 ---	4.00 ---	4.00 ---
20		---	---	2.5 ¹⁾	1.6 ¹⁾	1.0 ¹⁾	0.6 ¹⁾	---	---	---	4.00 ---	4.00 ---	4.00 ---	4.00 ---	4.00 ---	4.00 ---
20		---	4.0 ¹⁾	---	---	---	---	---	---	---	4.00 ---	4.00 ---	4.00 ---	4.00 ---	4.00 ---	4.00 ---
20		6.3 ¹⁾	---	---	---	---	---	---	---	---	3.77 ---	4.00 ---	4.00 ---	4.00 ---	4.00 ---	4.00 ---
25		---	---	---	2.5 ¹⁾	1.6 ¹⁾	---	---	---	---	---	4.00 ---	4.00 ---	4.00 ---	4.00 ---	4.00 ---
25		10.0	6.3 ²⁾	4.0 ²⁾	---	---	---	---	---	---	---	2.24 2.65	3.16 3.57	4.00 4.00	4.00 4.00	4.00 4.00
32		---	---	---	4.0 ¹⁾	---	---	---	---	---	---	4.00 ---	4.00 ---	4.00 ---	4.00 ---	4.00 ---
32		16.0	10.0	6.3 ²⁾	---	---	---	---	---	---	---	1.28 1.60	1.83 2.15	2.61 2.92	3.49 3.81	4.00 4.00
40		25.0	16.0	10.0	---	---	---	---	---	---	---	0.77 1.02	1.12 1.38	1.62 1.87	2.19 2.44	2.90 3.15
50	25	40.0	25.0	16.0	---	---	---	---	---	---	---	0.63 0.82	0.93 1.12	1.27 1.46	1.69 1.88	2.10 2.30
65		63.0	40.0	25.0	---	---	---	---	---	---	---	0.35 0.50	0.53 0.68	0.74 0.89	1.00 1.15	1.20 1.40
80	40	100.0	63.0	40.0	---	---	---	---	---	---	---	---	---	---	---	0.73 0.86
100		160.0	100.0	63.0	---	---	---	---	---	---	---	---	---	---	---	0.45 0.56
125		250.0	160.0	100.0	---	---	---	---	---	---	---	---	---	---	---	0.27 0.36
150		360.0	250.0	160.0	---	---	---	---	---	---	---	---	---	---	---	0.18 0.25

For further information on actuating, see actuators' catalogue sheets		Actuating (actuator)							AUMA Schiebel Rotork EMG	AUMA Schiebel Rotork EMG	Zepadyn Modact MTR PTN 6	Modact Cont. Modact MTN Auma Schiebel	Modact MTR ST 2 Zepadyn 671 PTN 7	Hand wheel)	
		Marking in valve specification No.							EA..., EZ..., EQ..., ED...	EA..., EZ..., EQ..., ED...	ENC EPD ERD	EYA EYB EA..., EZ...	EPD EPM ENE ERG	Rxx	
		Linear force							7,5 kN	10 kN	10 kN	15 kN	16 kN		
DN	H	Kvs [m ³ /hod]							Δp_{max}	Δp_{max}	Δp_{max}	Δp_{max}	Δp_{max}		
		1	2	3	4	5	6	7	metal PTFE	metal PTFE	metal PTFE	metal PTFE	metal PTFE	metal PTFE	
50	25	40.0	25.0	16.0	---	---	---	---	2.76 2.95	3.82 4.00	3.82 4.00	---	---	---	3.80 4.00
65		63.0	40.0	25.0	---	---	---	---	1.65 1.80	2.30 2.45	2.30 2.45	---	---	---	2.30 2.45
80	40	100.0	63.0	40.0	---	---	---	---	1.01 1.13	1.46 1.58	1.46 1.58	2.36 2.48	2.54 2.66	2.54 2.66	
100		160.0	100.0	63.0	---	---	---	---	0.63 0.73	0.92 1.02	0.92 1.02	1.50 1.61	1.62 1.72	1.62 1.72	
125		250.0	160.0	100.0	---	---	---	---	0.39 0.47	0.58 0.66	0.58 0.66	0.96 1.04	1.03 1.12	1.03 1.12	
150		360.0	250.0	160.0	---	---	---	---	0.26 0.33	0.39 0.46	0.39 0.46	0.66 0.73	0.71 0.78	0.71 0.78	

- 1) parabolic plug
 - 2) V-ported plug with linear characteristic, parabolic plug with equal-percentage, LDMspline® and parabolic characteristic.
 - 3) valve with micro-throttling trim. Execution with Kvs 0.01 to 0.063 m³/hour is possible after agreement with the producer. Equal-percentage, LDMspline® and parabolic characteristic available on condition : Kvs value ≥ 1.0
- Perforated plug available only with Kvs values in shadowed frames with the following restrictions:
- Kvs values 2.5 to 1.6 m³/hour available with linear characteristic only.
 - Perforated plug with Kvs value acc. to column No. 2 available with linear or parabolic characteristic only.

Max. differential pressure Δp for valves PN 16 must be 1.6 MPa.
 metal - version with metal - metal seat sealing
 PTFE - version with metal - PTFE seat sealing (is not applicable to contoured plugs)
 Max. differential pressures specified in table apply to PTFE and O-ring packing. Δp_{max} for bellows must be consulted with the producer. It applies to graphite packing as well especially when required Δp value is close to max. values specified in table.
 Δp_{max} values are set for the most unfavourable pressure ratios on the valve PN 40, but in concrete cases the real Δp_{max} value can be higher than values specified in the table above.

Kvs values and differential pressures Δp_{max} [MPa] of valves DN 200 - 400 with V-ported plugs (flow direction below plug)

Δp_{max} value is the valve max. differential pressure when open - close function is always guaranteed. In regard of service life of seat and plug, it is recommended so that differential pressure would not exceed 1.6 MPa. Otherwise it is suitable to use perforated plug or sealing surfaces of seat and plug with a hard metal overlay.

For further information on actuating, see actuators' catalogue sheets			Actuating (actuator)					AUMA Schiebel Rotork EMG Modact MTN Modact Cont.		Modact MTR ST 2 *) Zepadyn 671*) PTN 7 *)		AUMA Schiebel EMG		Modact MTR Modact MTN Modact Cont. ST 2 *) Zepadyn 671*) PTN 7 *)		AUMA Schiebel		Hand wheel
*) max. DN 300			Marking in valve specification No.					EA... EZ... EQ... ED... EYA EYB		EPD EPM ENE ERG		EA... EZ... ED... ENE ERG		EPD EYA EYB EPM		EA... EZ...		Rxx
Ds - Seat diameter			Linear force					15 kN		16 kN		20 kN		25 kN		32 kN		
			Kvs [m ³ /hod]					packing		packing		packing		packing		packing		packing
DN	Ds	H	1	2	3	4	5	grafit PTFE	grafit PTFE	grafit PTFE	grafit PTFE	grafit PTFE	grafit PTFE	grafit PTFE	grafit PTFE	grafit PTFE		
200	100	80	---	---	250	160	100	1.12 1.46	1.24 1.58	1.71 2.05	2.31 2.64	3.14 3.47	4.00					
	150		---	400	---	---	---	0.48 0.63	0.53 0.68	0.75 0.90	1.01 1.17	1.39 1.54	1.80					
	200		570	---	---	---	---	0.26 0.34	0.29 0.37	0.41 0.50	0.56 0.65	0.77 0.86	1.00					
250	150	80	---	---	400	250	160	0.41 0.59	0.47 0.64	0.68 0.86	0.95 1.13	1.33 1.50	1.80					
	200		---	630	---	---	---	0.22 0.32	0.25 0.35	0.37 0.47	0.52 0.62	0.74 0.84	1.00					
	230		800	---	---	---	---	0.16 0.23	0.18 0.26	0.27 0.35	0.39 0.46	0.55 0.63	0.75					
300	200	80	---	---	630	400	250	0.22 0.32	0.25 0.35	0.37 0.47	0.52 0.62	0.74 0.84	1.00					
	230		---	800	---	---	---	0.16 0.23	0.18 0.26	0.27 0.35	0.39 0.46	0.55 0.63	0.75					
	250		1000	---	---	---	---	0.13 0.19	0.15 0.21	0.23 0.29	0.33 0.39	0.46 0.53	0.60					
400	200	100	---	---	630	400	250	0.22 0.32	0.25 0.35	0.37 0.47	0.52 0.62	0.74 0.84	1.00					
	250		---	1000	---	---	---	0.13 0.19	0.15 0.21	0.23 0.29	0.33 0.39	0.46 0.53	0.60					
	330		1600	---	---	---	---	0.07 0.10	0.08 0.11	0.12 0.16	0.18 0.22	0.26 0.30	0.35					

Max. differential pressures specified in table are valid for seat sealing metal-metal and hard metal overlay on sealing surf.

Max. differential pressure Δp for valves PN 16 (PN 25) must be 1,6 MPa (2,5 MPa).

Kvs values and differential pressures Δp_{max} [MPa] of valves DN 200 - 400 with perforated plugs (flow direction above plug)

For further information on actuating, see actuators' catalogue sheets			Actuating (actuator)					AUMA Schiebel EMG Modact MTN Modact Cont.		Modact MTR ST 2 *)		AUMA Schiebel EMG		Modact MTR Modact MTN Modact Cont. ST 2 *)		AUMA Schiebel		Hand wheel
*) max. DN 300			Marking in valve specification No.					EA... EZ... ED... EYA EYB		EPD		EA... EZ... ED...		EPD EYA EYB EPM		EA... EZ...		Rxx
Ds - Seat diameter			Linear force					15 kN		16 kN		20 kN		25 kN		32 kN		
			Kvs [m ³ /hod]					packing		packing		packing		packing		packing		packing
DN	Ds	H	1	2	3	4	5	graph. PTFE	graph. PTFE	graph. PTFE	graph. PTFE	graph. PTFE	graph. PTFE	graph. PTFE	graph. PTFE	graph. PTFE		
200	200	80	---	400	250	160	100	0.26 0.34	0.29 0.37	0.41 0.50	0.56 0.65	0.77 0.86	1.00					
250	230	80	---	630	400	250	160	0.16 0.23	0.18 0.26	0.27 0.35	0.39 0.46	0.55 0.63	0.75					
300	250	80	---	800	630	400	250	0.13 0.19	0.15 0.21	0.23 0.29	0.33 0.39	0.46 0.53	0.60					
400	330	100	---	1000	630	400	250	0.07 0.10	0.08 0.11	0.12 0.16	0.18 0.22	0.26 0.30	0.35					

It is not possible to delivery perforated plugs for Kvs acc. to the column No. 1, for Kvs acc. to the column No.2 it is possible only with linear or parabolic characteristic. For another columns without limitation.

Max. differential pressures specified in table apply to PTFE and graphite packing.

Max. differential pressure Δp for valves PN 16 (PN 25) must be 1,6 MPa (2,5 MPa).

Dimensions and weights of valves made of spheroidal cast iron for the type RV / UV 210 (Ex), DN 15 - 150

DN	PN 16					PN 40					PN 16, PN 40																			
	D ₁	D ₂	D ₃	d	n	D ₁	D ₂	D ₃	d	n	D	f	D ₄	D ₅	L	V ₁	V ₂	*V ₂	V ₃	*V ₃	a	m	*m _v							
	mm	mm	mm	mm		mm	mm	mm	mm		mm	mm	mm	mm	mm	mm	mm	mm	mm	mm	mm	kg	kg							
15	95	65	46	14	4	95	65	46	14	4	15	2	65	M10x1	130	51	90	257	220	387	14	4.5	3.5							
20	105	75	56			105	75	56			20				150	54	90	257	220	387	16	5.5	3.5							
25	115	85	65			115	85	65			25				160	58	100	267	230	397	16	6.5	3.5							
32	140	100	76			140	100	76			32				180	70	100	267	230	397	18	8	3.5							
40	150	110	84	19	8	150	110	84	19	8	40	3	65	M16x1,5	200	75	100	267	230	397	19	9	3.5							
50	165	125	99			165	125	99			50				230	85	132	339	262	469	19	14	4							
65	185	145	118			185	145	118			65				290	93	132	339	262	469	19	18	4							
80	200	160	132			200	160	132			80				310	105	164	482	294	612	19	26	4.5							
100	220	180	156	23	8	235	190	156	23	8	100				350	118	164	482	294	612	19	38	4.5							
125	250	210	184			270	220	184			125				400	135	183	501	313	631	23.5	58	5							
150	285	240	211			23	8	300			250				211	28	8	150												

Dimensions and weights of valves made of cast steel and stainless steel for the type RV / UV 220 (Ex), RV / UV 230 (Ex) DN 15 - 150

DN	PN 16					PN 40					PN 16, PN 40																			
	D ₁	D ₂	D ₃	d	n	D ₁	D ₂	D ₃	d	n	D	f	D ₄	D ₅	L	V ₁	V ₂	*V ₂	V ₃	*V ₃	a	m	*m _v							
	mm	mm	mm	mm		mm	mm	mm	mm		mm	mm	mm	mm	mm	mm	mm	mm	mm	mm	mm	kg	kg							
15	95	65	45	14	4	95	65	45	14	4	15	2	65	M10x1	130	51	90	257	220	387	16	5.5	3.5							
20	105	75	58			105	75	58			20				150	54	90	257	220	387	18	6.5	3.5							
25	115	85	68			115	85	68			25				160	58	100	267	230	397	18	8	3.5							
32	140	100	78			140	100	78			32				180	70	100	267	230	397	18	9.5	3.5							
40	150	110	88	18	8	150	110	88	18	8	40	3	65	M16x1,5	200	75	100	267	230	397	18	11	3.5							
50	165	125	102			165	125	102			50				230	85	132	339	262	469	20	21	4							
65	185	145	122			185	145	122			65				290	93	132	339	262	469	20	27	4							
80	200	160	138			200	160	138			80				310	105	164	482	294	612	24	40	4.5							
100	220	180	158	22	8	235	190	162	22	8	100				350	118	164	482	294	612	24	49	4.5							
125	250	210	188			270	220	188			125				400	135	183	501	313	631	26	82	5							
150	285	240	212			22	8	300			250				218	26	8	150												

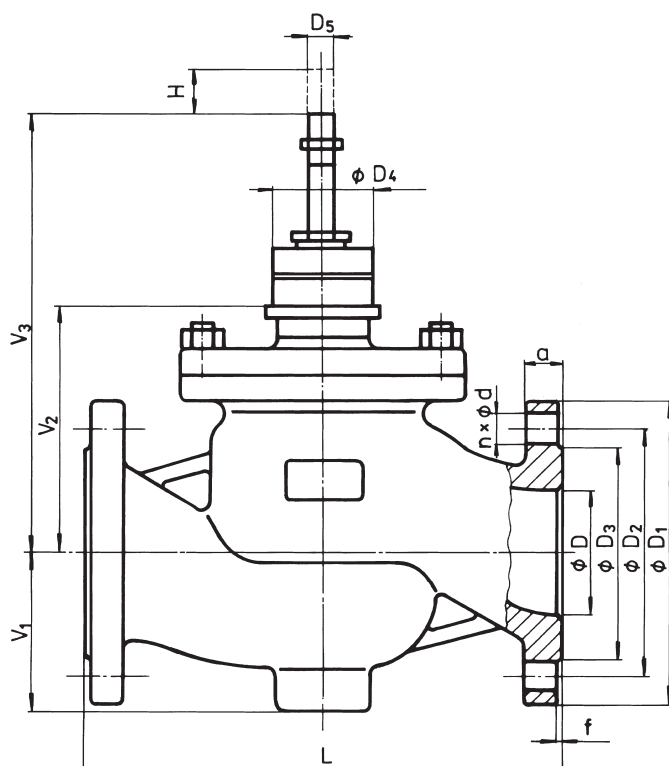

¹⁾ with regard of the standard previously in force, there is an option to have the number of connection bolts as stipulated in ČSN-EN 1092-1

^{#)} - for valve with bellows packing

m_v - weight to be added to weight of valve equipped with bellows packing

Dimensions and weights of valves made of spheroidal cast iron for the type RV / UV 210 (Ex), DN 200 - 400

DN	PN 16																		
	D ₁	D ₂	D ₃	d	n	a	D	D ₄	D ₅	M	L	V ₁	V ₂	V ₃	V ₄	f	H	m	
	mm	mm	mm	mm		mm	mm	mm	mm	mm	mm	mm	mm	mm	mm	mm	mm	mm	kg
200	340	295	266	23	12	20	200	---	M20x1.5	150	600	203	262	422	160	3	80	141	
250	405	355	319	22		250	---	730			253	346	506	3		259			
300	460	410	370	24.5		300	---	850			296	395	555	4		364			
400	580	525	480	31	16	28	400	---			1100	382	512	672		4	100	747	

Dimensions and weights of valves made of cast steel and stainless steel for the type RV / UV 2x0 (Ex), DN 200 - 400

DN	PN 16						PN 25						PN 40					
	D ₁	D ₂	D ₃	d	n	a	D ₁	D ₂	D ₃	d	n	a	D ₁	D ₂	D ₃	d	n	a
	mm	mm	mm	mm		mm	mm	mm	mm	mm		mm	mm	mm	mm	mm		mm
200	340	295	268	22	12	24	360	310	278	26	12	30	375	320	285	30	12	34
250	405	355	320	26		26	425	370	335	30		32	450	385	345	33		38
300	460	410	378	28		485	430	395	36	16	34	515	450	410	16	42		
400	580	525	490	30	16	32	620	550	505		36	40	660	585		535	39	50

DN	PN 16, 25, 40										
	D	D ₅	M	L	V ₁	V ₂	V ₃	V ₄	f	H	m
	mm	mm	mm	mm	mm	mm	mm	mm	mm	mm	kg
200	200	M20x1.5	150	600	203	262	422	160	2	80	220
250	250			730	253	346	506				390
300	300			850	296	395	555				570
400	400			1100	382	512	672				1170

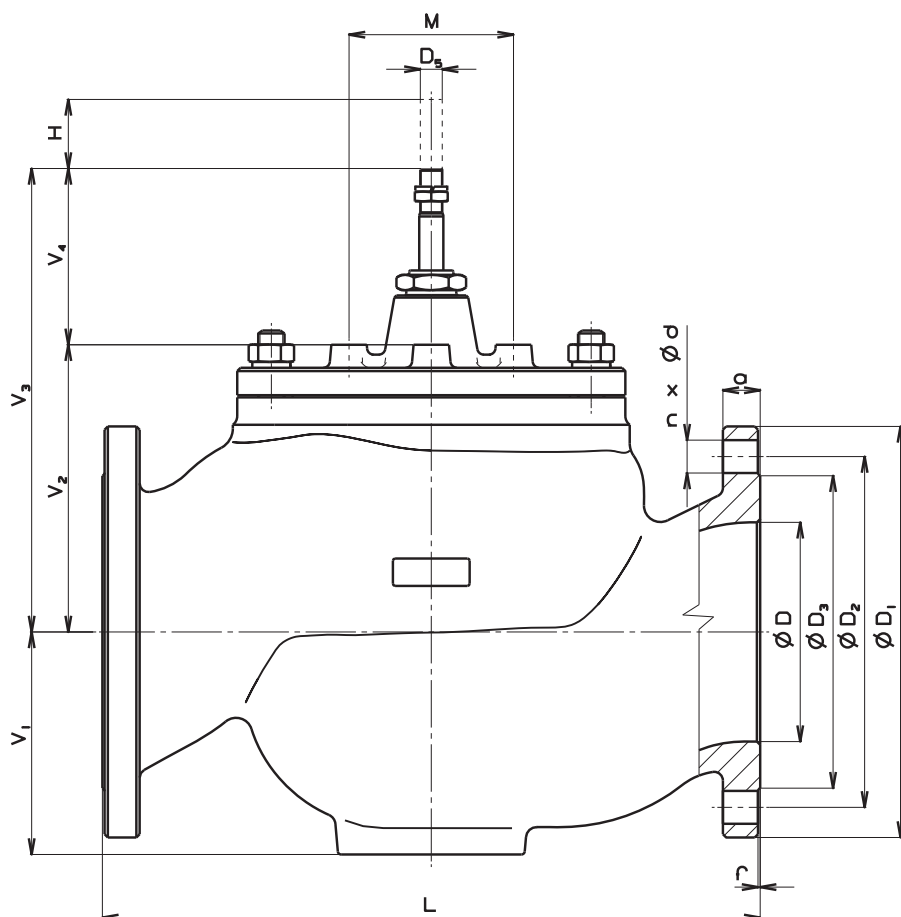



Control valves DN 25 -600, PN 16 and 40 with electromechanic actuators

Description

Control valves RV 212 (Ex), RV 222 (Ex) and RV 232 (Ex) [further only RV 2x2 (Ex)] are single-seated valves with pressure-balanced plug designed for regulation of process medium flow. In regard of used actuators, the valves are suitable for regulation at high differential pressures with low-linear-force actuators. Flow characteristics, Kvs values and leakage rates correspond to international standards.

Valves RV 2x2 (Ex) are equipped with hand wheel or are especially designed for electro-mechanic actuators of the following producers: ZPA Nová Paka, Ekorex+, Regada, ZPA Pečky, Auma, Schiebel, Drehmo and Rotork.

Application

The valves series RV 2x2 are designed for applications in heating, ventilation, power generation and chemical processing industries. The valves RV 2x2 Ex meet the requirements II 1/2G IIB die ČSN-EN 13463-1 (9/2002) and ČSN EN 1127-1 (9/1998), and in connection with suitable actuators, they are also designed for applications in gas and chemical industries. Valve body can be optionally made of spheroidal cast iron, cast steel and stainless steel.

The materials selected correspond to recommendations stipulated by ČSN-EN 1503-1 (1/2002) (steels) and ČSN-EN 1503-3 (1/2002) (cast). The maximal permissible operating pressures in behaviour with types of material and temperature are specified in the table on page 75 of this catalogue.

Process media

Valves series RV 2x2 are designed for regulation of flow and pressure of liquids, gases and vapours without abrasive particles e.g. water, steam, air and other media compatible with material of the valve inner parts. The valves series RV 2x2 Ex are also designed for control and shut-off of the flow and pressure of technical and fuel gases and inflammable liquids. The usage of the valve made of spheroidal cast iron (RV 212) for steam is limited by the following parameters. The steam must be superheated (its dryness at valve outlet $x_1 \geq 0,98$) and inlet pressure $p_1 \leq 0,4$ MPa when differential pressure is of above-critical value, and $p_1 \leq 1,6$ MPa when differential pressure is of under-critical value. In case these two conditions are not kept, it is necessary to use the valve made of cast steel (RV 222). To ensure a reliable regulation, the producers recommends to pipe a strainer in front of the valve into pipeline or ensure in any other way that process medium does not contain abrasive particles or impurities.

Installation

The valve is to be piped the way so that the direction of medium flow will coincide with the arrows on the body.

The valve can be installed in any position except position when the actuator is under the valve body.

Detailed informations are given in the instruction for installation and service.

Technical data

Series	RV 212 (Ex)	RV 222 (Ex)	RV 232 (Ex)
Type of valve	Two-way, single-seated, control valve with pressure-balanced plug		
Nominal size range	DN 25 to 400	DN 25 to 600	
Nominal pressure	DN 25-150: PN16/40, DN 200-400: PN16	PN 16, PN 25, PN 40	
Body material	Spheroidal cast iron EN-JS 1025 (EN-GJS-400-18-LT)	Cast steel 1.0619 (GP240GH) 1.7357 (G17CrMo5-5)	Stainless steel 1.4581 (GX5CrNiMoNb19-11-2)
Seat material:	DN 25 - 50 DN 65 - 400	1.4028 / 17 023.6 1.4027 / 42 2906.5	1.4571 / 17 347.4 1.4581 / 42 2941.4
Plug material:	DN 25 - 65 DN 80 - 150 DN 200 - 600	1.4021 / 17 027.6 1.4027 / 42 2906.5 1.4021 / 17 022.6	1.4571 / 17 347.4 1.4581 / 42 2941.4 1.4581 / 42 2941.4
Operating temperature range	-20 to 260°C	-20 to 260°C	-20 to 260°C
Face to face dimensions	Section 1 acc. to ČSN-EN 558-1 (3/1997)		
Flanges	Acc. to ČSN-EN 1092-1 (1/1999)	Acc. to ČSN-EN 1092-1 (2/2003)	
Flange face	Type B1 (raised-faced) acc. to ČSN-EN 1092-1 (1/1999)	Type B1 (raised-faced) or Type F (female) or Type D (groove) acc. to ČSN-EN 1092-1 (2/2003)	
Type of plug	V-ported, perforated		
Flow characteristic	Linear, equal-percentage, LDMspline®, parabolic		
Kvs value	4 to 4000 m ³ /hour		
Leakage rate	Class III. acc. ČSN-EN 1349 (5/2001) (<0.1% Kvs) for c. valves with metal-metal seat sealing Class IV. acc. ČSN-EN 1349 (5/2001) (<0.01% Kvs) for c. valves with metal-PTFE seat sealing		
Leakage rate for Ex version	Leakage rate 6 acc. to ČSN 13 3060 - section 2		
Rangeability r	50 : 1		
Packing	O - ring EPDM t _{max} =140°C, DRSpack® (PTFE) t _{max} =260°C, bellows t _{max} =260°C		

Kvs values and differential pressures Δp_{max} [MPa] of valves DN 25 - 150

Δp_{max} value is the valve max. differential pressure when open - close function is always guaranteed. In regard of service life of seat and plug, it is recommended so that

differential pressure would not exceed 1.6 MPa. Otherwise it is suitable to use perforated plug or sealing surfaces of seat and plug with a hard metal overlay.

For further information on actuating, see actuators' catalogue sheets		Actuating (actuator)		PTN 2.20 MIDI 660	ST 0	AUMA Schiebel Rotork EMG	Zepadyn ST 1 Ex ST 0.1 PTN 6	Modact Cont. Modact MTN	Modact MTR ST 2 Zepadyn 671 PTN 7	Hand Wheel			
		Marking in valve spec. No.		ERB ENB	EPK	EA..., EZ..., EQ..., ED...	ENC EPJ EPL ERD	EYA EYB	EPD EPM ENE ERG	Rxx			
		Linear force		2 kN	2,5 kN	5 kN	6,3 kN	15 kN	16 kN				
		Kvs [m ³ /hour]		Δp_{max}	Δp_{max}	Δp_{max}	Δp_{max}	Δp_{max}	Δp_{max}	Δp_{max}			
DN	H	1	2	3	4	5							
25	16	10.0	6.3 ¹⁾	4.0 ¹⁾	2.5 ¹⁾	1.6 ¹⁾	4.00	4.00	---	4.00	---	---	4.00
32		16.0	10.0	6.3 ¹⁾	4.0 ¹⁾	2.5 ¹⁾	4.00	4.00	---	4.00	---	---	4.00
40		25.0	16.0	10.0	6.3 ¹⁾	4.0 ¹⁾		4.00	4.00	---	4.00	---	---
50	25	40.0	25.0	16.0	10.0	6.3 ¹⁾	---	4.00	4.00	4.00	---	---	4.00
65		63.0	40.0	25.0	16.0	10.0	---	4.00	4.00	4.00	---	---	4.00
80	40	100.0	63.0	40.0	25.0	16.0	---	---	4.00	4.00	4.00	4.00	4.00
100		160.0	100.0	63.0	40.0	25.0	---	---	4.00	4.00	4.00	4.00	4.00
125		250.0	160.0	100.0	63.0	40.0	---	---	4.00	4.00	4.00	4.00	4.00
150		360.0	250.0	160.0	100.0	63.0	---	---	4.00	4.00	4.00	4.00	4.00

1) linear characteristic only

Valves RV 2x2 can be optionally assembled with all the actuators specified in catalogue sheet RV / UV 2x0.

Max. differential pressures specified in table apply to PTFE and O-ring packing. Δp_{max} for bellows must be consulted with the producer.

Perforated plug available only with Kvs values in shadowed frames with the following restrictions:

- Perforated plug with Kvs value acc. to column No. 2 available with linear or parabolic characteristic only.

Max. differential pressure Δp for valves PN 16 must be 1.6 MPa.

Kvs values and differential pressures Δp_{max} [MPa] of valves DN 200 - 600

Δp_{max} value is the valve max. differential pressure when open - close function is always guaranteed. In regard of service life of seat and plug, it is recommended so that

differential pressure would not exceed 1.6 MPa. Otherwise it is suitable to use perforated plug or sealing surfaces of seat and plug with a hard metal overlay.

For further information on actuating, see actuators' catalogue sheets		Actuating (actuator)		AUMA Schiebel EMG Modact MTN Modact Cont.	Modact MTR ST 2 Zepadyn 671 PTN 7	AUMA Schiebel EMG Zepadyn 671*) PTN 7 *)	Modact MTR Modact MTN Modact Cont. ST 2 *)	AUMA Schiebel	Hand wheel				
		Marking in valve spec. No.		EA... EZ... ED... EYA EYB	EPD EPM ENE ERG	EA... EZ... ED... ENE ERG	EPD EYA EYB EPM	EA... EZ...	Rxx				
		Osová síla		15 kN	16 kN	20 kN	25 kN	32 kN					
		Kvs [m ³ /h]		packing	packing	packing	packing	packing	packing				
DN	Ds	H	1	2	3	4	5	graphitePTFE	graphitePTFE	graphitePTFE	graphitePTFE	graphitePTFE	graphitePTFE
200	200	80	570	400	250	160	100	4.00	4.00	---	---	---	4.00
250	230	80	800	630	400	250	160	---	---	4.00	4.00	---	4.00
300	250	80	1000	800	630	400	250	---	---	4.00	4.00	---	4.00
400	330	100	1600	1000	630	400	250	---	---	4.00	4.00	---	4.00
600	500	120	4000	2500	1600	1000	630	---	---	---	---	4.00	---

It is not possible to delivery perforated plugs for Kvs acc. to the column No. 1, for Kvs acc. to the column No.2 it is possible only with linear or parabolic characteristic. For another columns without limitation.

Max. differential pressures specified in table apply to PTFE and graphite packing.

Max. differential pressure Δp for valves PN 16 (PN 25) must be 1,6 MPa (2,5 MPa).

Dimensions and weights of valves made of spheroidal cast iron for the type RV 212 (Ex) DN 25 - 150

DN	PN 16					PN 40					PN 16, PN 40												
	D ₁	D ₂	D ₃	d	n	D ₁	D ₂	D ₃	d	n	D	f	D ₄	D ₅	L	V ₁	V ₂	[#] V ₂	V ₃	[#] V ₃	a	m	[#] m _v
	mm	mm	mm	mm		mm	mm	mm	mm		mm	mm	mm	mm	mm	mm	mm	mm	mm	mm	mm	kg	kg
25	115	85	65	14	4	115	85	65	14	4	25	3	65	M10x1	160	58	100	267	230	397	16	7	3.5
32	140	100	76	140		100	76	32	180		70				100	267	230	397	18	8.5	3.5		
40	150	110	84	150		110	84	40	200		75				100	267	230	397	19	8.5	3.5		
50	165	125	99	165		125	99	50	230		85				132	339	262	469	19	14.5	4		
65	185	145	118	19	185	145	118	19	8	65	80	100	M16x1,5	290	93	132	339	262	469	19	18.5	4	
80	200	160	132		200	160	132			80				310	105	164	482	294	612	19	27.5	4.5	
100	220	180	156	8	235	190	156	23	8	100	125	150	M16x1,5	350	118	164	482	294	612	19	39	4.5	
125	250	210	184		270	220	184	125		400				135	183	501	313	631	23.5	60	5		
150	285	240	211		300	250	211	150		480				150	200	518	330	648	26	81	5		

Dimensions and weights of valves made of cast steel and stainless steel for the type RV 222 (Ex), RV 232 (Ex) DN 25 - 150

DN	PN 16					PN 40					PN 16, PN 40												
	D ₁	D ₂	D ₃	d	n	D ₁	D ₂	D ₃	d	n	D	f	D ₄	D ₅	L	V ₁	V ₂	[#] V ₂	V ₃	[#] V ₃	a	m	[#] m _v
	mm	mm	mm	mm		mm	mm	mm	mm		mm	mm	mm	mm	mm	mm	mm	mm	mm	mm	mm	kg	kg
25	115	85	68	14	4	115	85	68	14	4	25	2	65	M10x1	160	58	100	267	230	397	18	8.5	3.5
32	140	100	78	140		100	78	32	180		70				100	267	230	397	18	10	3.5		
40	150	110	88	150		110	88	40	200		75				100	267	230	397	18	10	3.5		
50	165	125	102	165		125	102	50	230		85				132	339	262	469	20	21	4		
65	185	145	122	18	4 ¹⁾	185	145	122	18	8	65	80	M16x1,5	290	93	132	339	262	469	22	27	4	
80	200	160	138		200	160	138	80			310			105	164	482	294	612	24	42	4.5		
100	220	180	158	8	8	235	190	162	22	8	100	125	M16x1,5	350	118	164	482	294	612	24	50	4.5	
125	250	210	188		270	220	188	125	400		135			183	501	313	631	26	84	5			
150	285	240	212		300	250	218	150	480		150			200	518	330	648	28	103	5			

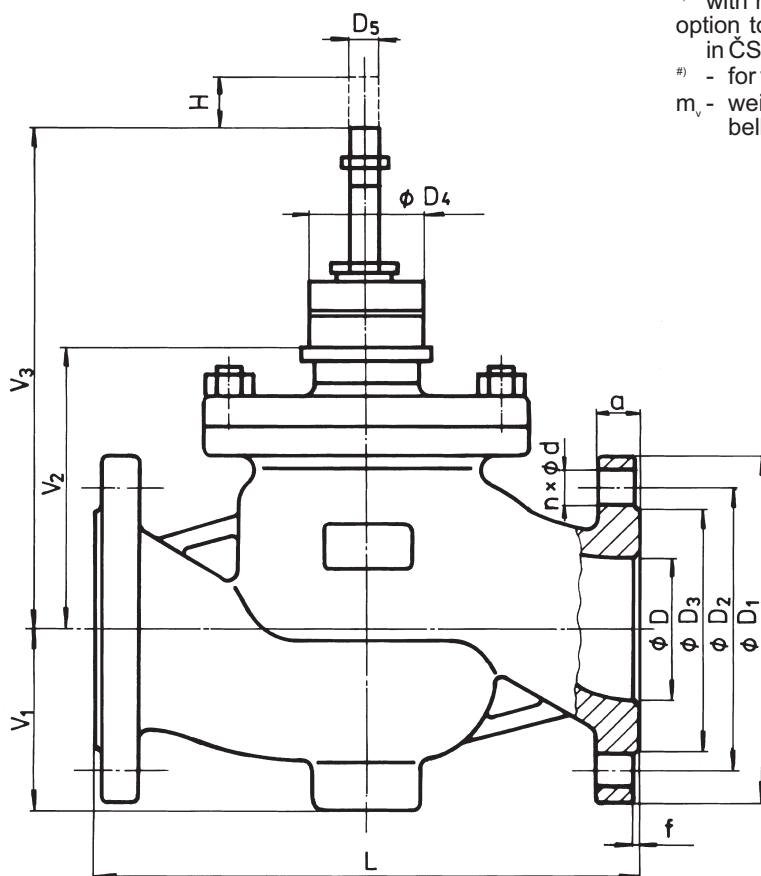

¹⁾ with regard of the standard previously in force, there is an option to have the number of connection bolts as stipulated in ČSN-EN 1092-1

[#] - for valve with bellows packing

m_v - weight to be added to weight of valve equipped with bellows packing

Dimensions and weights of valves made of spheroidal cast iron for the type RV 212 (Ex), DN 200 - 400

DN	PN 16																	
	D ₁	D ₂	D ₃	d	n	a	D	D ₅	M	L	V ₁	V ₂	V ₃	V ₄	f	H	m	
	mm	mm	mm	mm		mm	mm	mm	mm	mm	mm	mm	mm	mm	mm	mm	mm	kg
200	340	295	266	23	12	20	200	M20x1.5	150	600	203	262	422	160	3	80	153	
250	405	355	319	28		22	250			730	253	346	506		3		264	
300	460	410	370	24.5		300	850			296	395	555	4		390			
400	580	525	480	31	16	28	400			1100	382	512	672		4	100	790	

Dimensions and weights of valves made of cast steel and stainless steel for the type RV 222, 232 (Ex), DN 200 - 600

DN	PN 16						PN 25						PN 40					
	D ₁	D ₂	D ₃	d	n	a	D ₁	D ₂	D ₃	d	n	a	D ₁	D ₂	D ₃	d	n	a
	mm	mm	mm	mm		mm	mm	mm	mm	mm		mm	mm	mm	mm	mm		mm
200	340	295	268	22	12	24	360	310	278	26	12	30	375	320	285	30	12	34
250	405	355	320	26		26	425	370	335	30		32	450	385	345	33		38
300	460	410	378	28		485	430	395	36	16	34	515	450	410	16	42		
400	580	525	490	30	16	32	620	550	505		36	40	660	585		535	39	50
600	840	770	725	36	20	54	845	770	720	39	20	58	890	795	735	48	20	72

DN	PN 16, 25, 40										
	D	D ₅	M	L	V ₁	V ₂	V ₃	V ₄	f	H	m
	mm	mm	mm	mm	mm	mm	mm	mm	mm	mm	kg
200	200	M20x1.5	150	600	203	262	422	160	2	80	232
250	250			730	253	346	506				395
300	300			850	296	395	555				596
400	400			1100	382	512	672				1213
600	580	M30x2	300	1450	590	675	885	210	5	120	3500

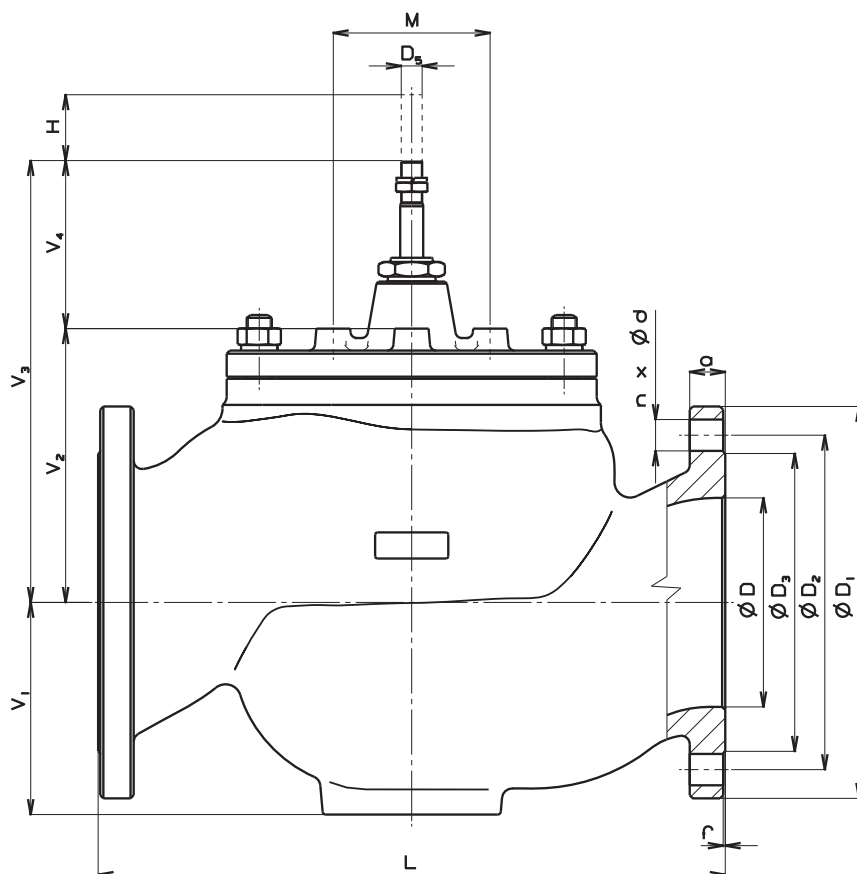



Control valves DN 15 - 300, PN 16, 25 and 40 with electromechanic actuators

Description

Control valves RV 214 (Ex), RV 224 (Ex) and RV 234 (Ex) (further only RV 2x4 (Ex)) are three-way valves with mixing or flow-diverting function. In regard of a great variety of used actuators, the valves are suitable for regulation at low as well as high differential pressures in a diversity of operating conditions. Flow characteristics, Kvs values and leakage rates correspond to international standards.

valves RV 2x4 (Ex) are equipped with hand wheel or are especially designed for electro-mechanic actuators of the following producers: Ekorex+, ZPA Nová Paka, Regada, ZPA Pečky, Auma, Schiebel, Drehmo and Rotork.

Application

These valves have a wide range of application in heating, ventilation, power generation and chemical processing industries.

The valves UV 2x4 Ex meet the requirements II 1/2G IIB acc. to ČSN-EN 13 463-1 (9/2002) and to ČSN-EN 1127-1 (9/1998) and assembled with suitable actuators, they are used for gas and chemical industrial applications.

Valve body can be optionally made of spheroidal cast iron, cast steel and austenitic stainless steel according to operating conditions.

The materials selected correspond to recommendations stipulated by ČSN-EN 1503-1 (1/2002) (steels). The maximal permissible operating pressures in behaviour with types of material and temperature are specified in the table on page 75 of this catalogue.

Process media

Valves series RV 2x4 are designed for regulation of flow and pressure of liquids, gases and vapours without abrasive particles e.g. water, steam, air and other media compatible with material of the valve inner parts. The usage of the valve made of spheroidal cast iron (RV 214) for steam is limited by the following parametres. The steam must be superheated (its dryness at valve outlet $x_v \geq 0,98$) and inlet pressure $p_i \leq 0,4$ MPa when differential pressure is of above-critical value, and $p_i \leq 1,6$ MPa when differential pressure is of under-critical value. In case these two conditions are not kept, it is necessary to use the valve made of cast steel (RV 224). To ensure a reliable regulation, the producers recommends to pipe a strainer in front of the valve into pipeline or ensure in any other way that process medium does not contain abrasive particles or impurities.

Installation

When the valve is used as mixing, it must be piped the way so that direction of process medium flow will coincide with the arrows on the body (inlet ports A, B and outlet port AB). When the valve is used as diverting, process medium flows through common valve port AB and split streams leave through valve ports A and B.

The valve can be installed in any position except position when the actuator is under the valve body.

Detailed informations are given in the instruction for installation and service.

Technical data

Series	RV 214	RV 224	RV 234
Type of valve	Three-way reverse control valve		
Nominal size range	DN 15 to 300	DN 15 to 300	
Nominal pressure	DN 25-150: PN16;40, DN 200-300: PN16	PN 16, PN 25, PN 40	
Body material	Spheroidal cast iron EN-JS 1025 (EN-GJS-400-18-LT)	Cast steel 1.0619 (GP240GH) 1.7357 (G17CrMo5-5)	Stainless steel 1.4581 (GX5CrNiMoNb19-11-2)
Seat material:	DN 25 - 50 DN 65 - 300	1.4028 / 17 023.6 1.4027 / 42 2906.5	1.4571 / 17 347.4 1.4581 / 42 2941.4
Plug material:	DN 25 - 65 DN 80 - 300	1.4021 / 17 027.6 1.4027 / 42 2906.5	1.4571 / 17 347.4 1.4581 / 42 2941.4
Operating temperature range	-20 to 300°C	-20 to 500°C	-20 to 400°C
Face to face dimensions	Section 1 acc. to ČSN-EN 558-1 (3/1997)		
Flanges	Acc. to ČSN-EN 1092-1 (1/1999)	Acc. to ČSN-EN 1092-1 (2/2003)	
Flange face	Type B1 (raised-faced) acc. to ČSN-EN 1092-1 (1/1999)	Type B1 (raised-faced) or Type F (female) or Type D (groove) acc. to ČSN-EN 1092-1 (2/2003)	
Type of plug	V-ported, contoured		
Flow characteristic	Linear, equal-percentage, LDMspline®, parabolic		
Kvs value	1.6 to 1000 m ³ /hod		
Leakage rate	Class III. acc. ČSN-EN 1349 (5/2001) (<0.1% Kvs) for c. valves with metal-metal seat sealing Class IV. acc. ČSN-EN 1349 (5/2001) (<0.01% Kvs) for c. valves with metal-PTFE seat sealing		
Leakage rate for Ex version	Leakage rate 6 acc. to ČSN 13 1060 - section 2		
Rangeability r	50 : 1		
Packing	O - ring EPDM $t_{max}=140^{\circ}C$, DRSpack® (PTFE) $t_{max}=260^{\circ}C$, bellows $t_{max}=500^{\circ}C$		

Kvs values and differential pressures

Δp_{max} value is the valve max. differential pressure when open - close function is always guaranteed. In regard of service life of seat and plug, it is recommended so that

differential pressure would not exceed 1.6 MPa. Otherwise it is suitable to use perforated plug or sealing surfaces of seat and plug with a hard metal overlay.

For further information on actuating, see actuators' catalogue sheets		Actuating (actuator)	PTN 2.20 MIDI 660	ST 0	PTN 2.32 MIDI 660	MIDI 660 ST 0 ST 0.1 PTN 2.40	AUMA Schiebel Rotork EMG	Zepadyn ST 1 EX ST 0.1 PTN 6	AUMA Schiebel Rotork EMG	Hand wheel		
		Marking in valve specification No.	ERB ENB	EPK	ERC ENB	ENB EPK EPL ERC	EA..., EZ..., EQ..., ED...	ENC EPJ EPL ERD	EA... EZ... EQ... ED...	Rxx		
		Linear force	2 kN	2,5 kN	3,2 kN	4,0 kN	5 kN	6,3 kN	7,5 kN			
		Kvs [m ³ /h]	Δp_{max}	Δp_{max}	Δp_{max}	Δp_{max}	Δp_{max}	Δp_{max}	Δp_{max}	Δp_{max}		
DN	H	1	2	3	metal PTFE	metal PTFE	metal PTFE	metal PTFE	metal PTFE	metal PTFE	metal PTFE	metal PTFE
15	16	4.0 ¹⁾	2.5 ¹⁾	1.6 ¹⁾	4.00 ---	4.00 ---	4.00 ---	4.00 ---	4.00 ---	4.00 ---	---	4.0
20		6.3 ¹⁾	4.0 ¹⁾	2.5 ¹⁾	3.77 ---	4.00 ---	4.00 ---	4.00 ---	4.00 ---	4.00 ---	---	4.0
25		10.0	6.3 ²⁾	4.0 ²⁾	2.24 2.65	3.16 3.57	4.00 4.00	4.00 4.00	4.00 4.00	4.00 4.00	---	4.0
32		16.0	10.0	6.3 ²⁾	1.28 1.60	1.83 2.15	2.61 2.92	3.49 3.81	4.00 4.00	4.00 4.00	---	4.0
40		25.0	16.0	10.0	0.77 1.02	1.12 1.38	1.62 1.87	2.19 2.44	2.90 3.15	3.60 3.90	---	4.0
50	25	40.0	25.0	16.0	---	0.63 0.82	0.93 1.12	1.27 1.46	1.69 1.88	2.10 2.30	2.76 2.95	3.8 4.0
65		63.0	40.0	25.0	---	0.35 0.50	0.53 0.68	0.74 0.89	1.00 1.15	1.20 1.40	1.65 1.80	2.3 2.45
80	40	100.0	63.0	40.0	---	---	---	---	---	0.73 0.86	1.01 1.13	2.54 2.66
100		160.0	100.0	63.0	---	---	---	---	---	0.45 0.56	0.63 0.73	1.62 1.72
125		250.0	160.0	100.0	---	---	---	---	---	0.27 0.36	0.39 0.47	1.03 1.12
150		360.0	250.0	160.0	---	---	---	---	---	0.18 0.25	0.26 0.33	0.71 0.78

For further information on actuating, see actuators' catalogue sheets		Actuating (actuator)	Zepadyn PTN 6	Auma Schiebel Rotork EMG Modact MTR	Modact Cont. Modact MTN AUMA Schiebel Rotork EMG	Modact MTR ST 2 Zepadyn 671 PTN 7	AUMA Schiebel EMG Zepadyn 671 PTN 7	Modact Cont. Modact MTN Modact MTR ST 2	Auma Schiebel	Hand wheel		
		Marking in valve specification No.	ENC ERD	EA... EZ... EQ... ED... EPD	EYA EYB EA... EZ... EQ... ED...	EPD EPM ENE ERG	EA... EZ... ED... ENE ERG	EYA EYB EPD EPM	EA... EZ...	Rxx		
		Linear force	10 kN	10 kN	15 kN	16 kN	20 kN	25 kN	32 kN			
		Kvs [m ³ /h]	Δp_{max}	Δp_{max}	Δp_{max}	Δp_{max}	Δp_{max}	Δp_{max}	Δp_{max}	Δp_{max}		
DN	H	1	2	3	metal PTFE	metal PTFE	metal PTFE	metal PTFE	metal PTFE	metal PTFE	metal PTFE	metal PTFE
50	25	40.0	25.0	16.0	3.82 4.00	3.82 4.00	---	---	---	---	---	---
65		63.0	40.0	25.0	2.30 2.45	2.30 2.45	---	---	---	---	---	---
80	40	100.0	63.0	40.0	1.46 1.58	1.46 1.58	2.36 2.48	2.54 2.66	---	---	---	---
100		160.0	100.0	63.0	0.92 1.02	0.92 1.02	1.50 1.61	1.62 1.72	---	---	---	---
125		250.0	160.0	100.0	0.58 0.66	0.58 0.66	0.96 1.04	1.03 1.12	---	---	---	---
150		360.0	250.0	160.0	0.39 0.46	0.39 0.46	0.66 0.73	0.71 0.78	---	---	---	---
200	80	570.0	400.0	250.0	---	0.19 ---	0.34 ---	0.37 ---	0.50 ---	0.65 ---	0.86 ---	1.0
250		800.0	630.0	400.0	---	0.11 ---	0.23 ---	0.25 ---	0.35 ---	0.46 ---	0.62 ---	0.75
300		1000.0	800.0	630.0	---	0.09 ---	0.19 ---	0.21 ---	0.29 ---	0.39 ---	0.53 ---	0.60

1) parabolic plug in straight way, V-ported plug in angle way
2) V-ported plug in angle way, in straight way V-ported plug for linear characteristic and for equal-percentage characteristic parabolic plug.

Bellows packing can be used for DN 15 and 20.

Max. differential pressure Δp for valves PN 16 must be 1.6 MPa.

metal - version with metal - metal seat sealing

PTFE - version with metal - PTFE seat sealing (is not applicable to contoured plugs)

Max. differential pressures specified in table apply to PTFE and O-ring packing. Δp_{max} for bellows must be consulted with the producer. It applies to graphite packing as well especially when required Δp value is close to max. values specified in table.

Dimensions and weights of valves made of spheroidal cast iron for the types RV 214 (Ex), DN 15 - 150

DN	PN 16					PN 40					PN 16, PN 40												
	D ₁	D ₂	D ₃	d	n	D ₁	D ₂	D ₃	d	n	D	f	D ₄	D ₅	L	V ₁	V ₂	#V ₂	V ₃	#V ₃	a	m	#m _v
	mm	mm	mm	mm		mm	mm	mm	mm		mm	mm	mm	mm	mm	mm	mm	mm	mm	mm	mm	kg	kg
15	95	65	46	14	4	95	65	46	14	4	15	2	65	M10x1	130	110	67	---	197	---	14	5.5	3.5
20	105	75	56			105	75	56			20				150	115	67	---	197	---	16	6.5	3.5
25	115	85	65			115	85	65			25				160	130	72	239	202	369	16	8.3	3.5
32	140	100	76			140	100	76			32				180	135	72	239	202	369	18	10.5	3.5
40	150	110	84	19	8	150	110	84	19	8	40	3	65	M10x1	200	140	72	239	202	369	19	12	3.5
50	165	125	99			165	125	99			50				230	175	92	299	222	429	19	17	4
65	185	145	118			185	145	118			65				290	180	92	299	222	429	19	22	4
80	200	160	132			200	160	132			80				310	220	123	441	253	571	19	31	4.5
100	220	180	156	23	8	235	190	156	23	8	100	3	65	M16x1,5	350	230	123	441	253	571	19	44	4.5
125	250	210	184			270	220	184			125				400	260	151	469	281	599	23.5	65	5
150	285	240	211			300	250	211			150				480	290	151	469	281	599	26	94	5

Dimensions and weights of valves made of cast steel and stainless steel for the types RV 224 (Ex), RV 234 (Ex) DN 15 - 150

DN	PN 16					PN 40					PN 16, PN 40												
	D ₁	D ₂	D ₃	d	n	D ₁	D ₂	D ₃	d	n	D	f	D ₄	D ₅	L	V ₁	V ₂	#V ₂	V ₃	#V ₃	a	m	#m _v
	mm	mm	mm	mm		mm	mm	mm	mm		mm	mm	mm	mm	mm	mm	mm	mm	mm	mm	mm	kg	kg
15	95	65	45	14	4	95	65	45	14	4	15	2	65	M10x1	130	110	67	---	197	---	16	6	3.5
20	105	75	58			105	75	58			20				150	115	67	---	197	---	18	7	3.5
25	115	85	68			115	85	68			25				160	130	72	239	202	369	18	9.5	3.5
32	140	100	78			140	100	78			32				180	135	72	239	202	369	18	12	3.5
40	150	110	88	18	4 ¹⁾	150	110	88	18	8	40	3	65	M10x1	200	140	72	239	202	369	18	13.5	3.5
50	165	125	102			165	125	102			50				230	175	92	299	222	429	20	24	4
65	185	145	122			185	145	122			65				290	180	92	299	222	429	22	31	4
80	200	160	138			200	160	138			80				310	220	123	441	253	571	24	43	4.5
100	220	180	158	22	8	235	190	162	22	8	100	3	65	M16x1,5	350	230	123	441	253	571	24	55	4.5
125	250	210	188			270	220	188			125				400	260	151	469	281	599	26	90	5
150	285	240	212			300	250	218			150				480	290	151	469	281	599	28	120	5

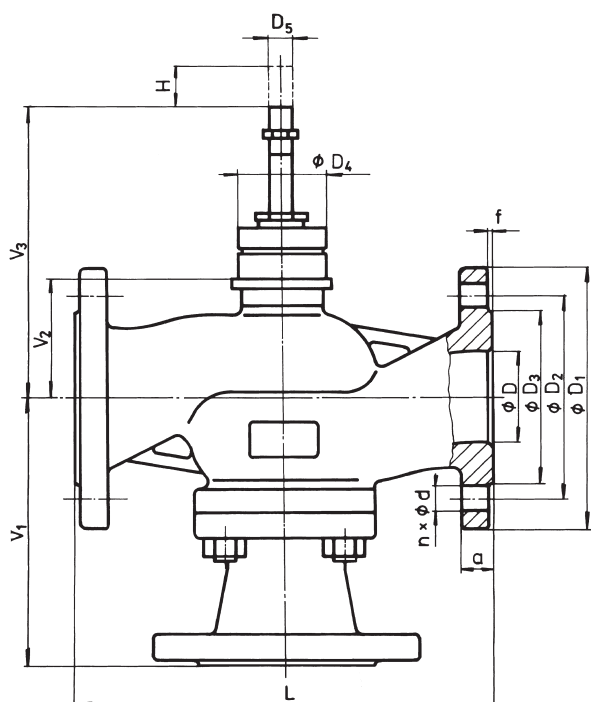

RV 2x4 DN 15 to 150

¹⁾ with regard of the standard previously in force, there is an option to have the number of connection bolts as stipulated in ČSN-EN 1092-1

^{#)} - for valve with bellows packing

m_v - weight to be added to weight of valve equipped with bellows packing

Dimensions and weights of valves made of spheroidal cast iron for the type RV 214 (Ex), DN 200 - 300

DN	PN 16																	
	D ₁	D ₂	D ₃	d	n	a	D	D ₅	M	L	V ₁	V ₂	V ₃	V ₄	f	H	m	
	mm	mm	mm	mm		mm	mm	mm	mm	mm	mm	mm	mm	mm	mm	mm	mm	kg
200	340	295	266	23	12	20	200	M20x1.5	150	600	400	265	425	160	3	80	162	
250	405	355	319	28		22	250			730	480	360	520		3		280	
300	460	410	370	24.5		300	850			560	402	562	4		410			

Dimensions and weights of valves made of cast steel and stainless steel for the types RV 224, 234 (Ex), DN 200 - 300

DN	PN 16							PN 25					PN 40					
	D ₁	D ₂	D ₃	d	n	a	D ₁	D ₂	D ₃	d	n	a	D ₁	D ₂	D ₃	d	n	a
	mm	mm	mm	mm		mm	mm	mm	mm	mm		mm	mm	mm	mm	mm		mm
200	340	295	268	22	12	24	360	310	278	26	12	30	375	320	285	30	12	34
250	405	355	320	26		26	425	370	335	30		32	450	385	345	33		38
300	460	410	378	28		28	485	430	395	30	16	34	515	450	410	33	16	42

DN	PN 16, 25, 40										
	D	D ₅	M	L	V ₁	V ₂	V ₃	V ₄	f	H	m
	mm	mm	mm	mm	mm	mm	mm	mm	mm	mm	kg
200	200	M20x1.5	150	600	400	265	425	160	2	80	250
250	250			730	480	360	520				425
300	300			850	560	402	562				640

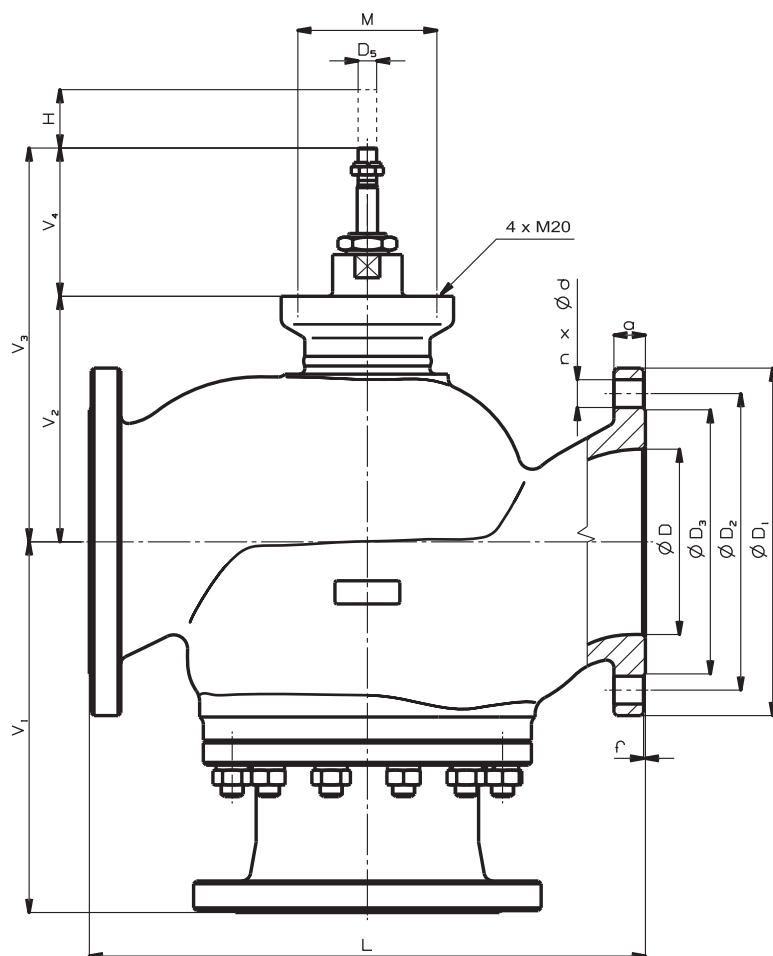

RV 2x4 DN 200 to 300

Valve complete specification No. for ordering RV / UV 2x0 (Ex), RV 2x2 (Ex), RV 2x4

		XX	XXX	XXX	XXXX	XX	-XX	/XXX	-XXX	XX
1. Valve	Control valve	RV								
	Shut-off valve	UV								
2. Series	Valves made of spheroidal cast iron EN-JS 1025 ²⁾		2 1							
²⁾ For DN 200 to 400 only for PN 16	Valves made of cast steel 1.0619, 1.7357		2 2							
	Valves made of stainless steel 1.4581		2 3							
	Direct valve		0							
	Pressure -balanced valve		2							
	Mixing (diverting) valve		4							
3. Actuating	Electric actuator			E X X						
Specifications of actuators acc. to table on page No. 75	Hand wheel			R X X						
4. Connecting	Raised flange				1					
	Female flange				2					
	Flange with groove				3					
5. Body material	Cast steel 1.0619 (-20 to 400°C)				1					
	Sphr. cast iron EN-JS 1025 (-20 to 300°C)				4					
	CrMo steel 1.7357 (-20 to 500°C)				7					
(Operating temperature ranges are specified in parentheses)	Stainless steel 1.4581 (-20 to 400°C)				8					
	Other material on request				9					
6. Seat sealing	Metal - metal				1					
¹⁾ From DN 25; $t_{max} = 260^\circ\text{C}$	Soft sealing (metal - PTFE) ¹⁾				2					
	Hard metal overlay on sealing surfaces				3					
7. Packing	O - ring EPDM				1					
³⁾ Not applicable to Ex execution	DRSpack® (PTFE)				3					
⁶⁾ Only for DN 15 to 150	Exp. graphite ³⁾				5					
	Bellows ⁶⁾				7					
	Bellows with safety PTFE packing ⁶⁾				8					
	Bellows with safety Graphite packing ⁶⁾				9					
8. Flow characteristic	Linear					L				
⁴⁾ Applicable to UV 2x0 only	Equal-percentage in straight way					R				
⁵⁾ Not applicable to RV 2x4	LDMspline ⁵⁾					S				
	On-off ⁴⁾					U				
	Parabolic ⁵⁾					P				
	Linear - perforated plug ⁵⁾					D				
	Equal-percentage - perforated plug ⁵⁾					Q				
	Parabolic - perforated plug ⁵⁾					Z				
9. Kvs	Column No. acc. to Kvs value table					X				
10. Nominal pressure PN	PN 16						16			
	PN 25 (DN 200 to 600)						25			
	PN 40						40			
11. Max. operating temp. °C	O - ring EPDM							140		
	DRSpack® (PTFE), bellows							220		
	DRSpack® (PTFE), bellows							260		
	Exp. graphite; bellows							300		
	Exp. graphite; bellows							400		
	Exp. graphite; bellows							550		
12. Nominal size DN	DN								XXX	
13. Execution	Normal									
	Non - explosive									Ex
	Oxygen									Ox
	Food industry execution									Px

Ordering example: RV210 ENC 1423 L1 40/220-065

For marking of actuators in specification code, refer to table on page No. 75 of this catalogue

Valves RV / UV 2x0 (Ex)

Section of valve with V-ported plug

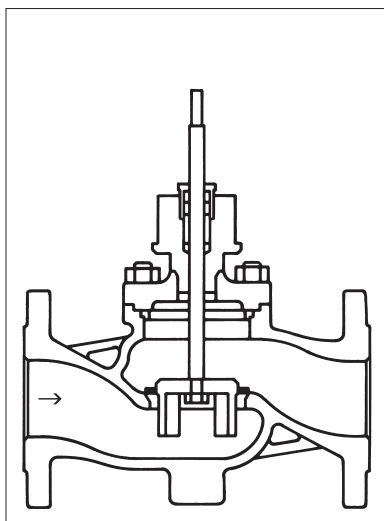

Section of valve with perforated plug

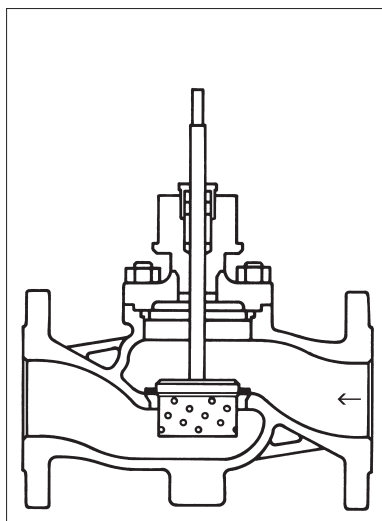

Section of valve with micro-throttling system

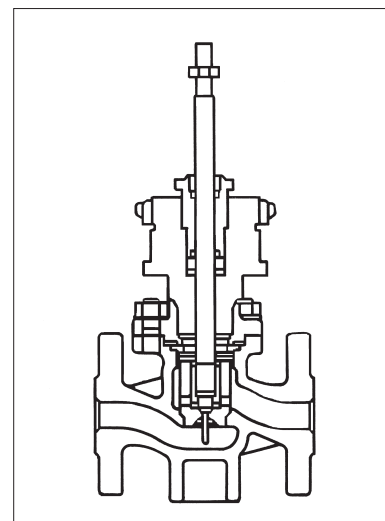

Valves RV 2x2 (Ex)

Section of pressure-balanced valve with V-ported plug

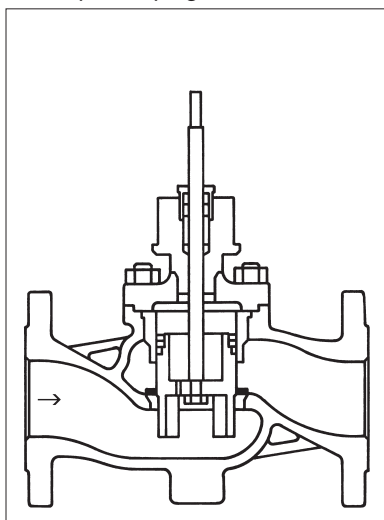

Section of pressure-balanced valve with perforated plug

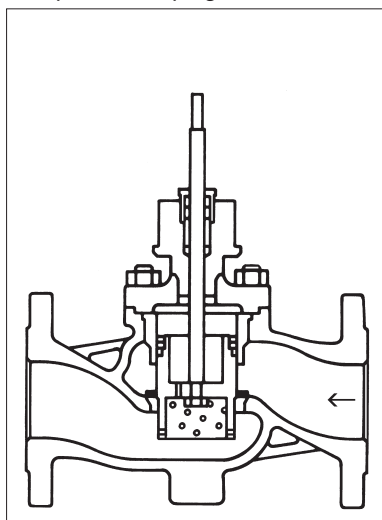

Valve RV 2x4 (Ex)

Section of three-way valve with V-ported plug

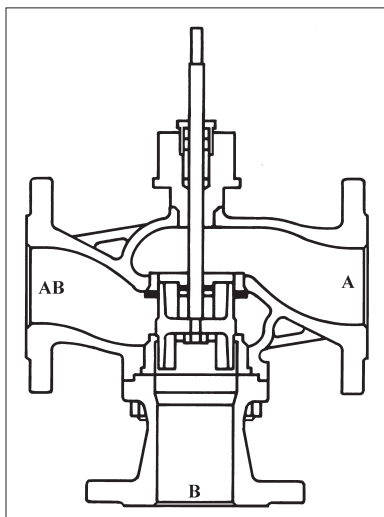



Electric actuator PIKO 524 65 ZPA Nová Paka

Technical data

Type	PIKO 524 65.XXXX
Marking in valve specification No.	END
Voltage	230 V AC or 24 V AC
Frequency	50 ± 2 Hz
Power consumption	Max. 9 VA
Control	3 - position control
Nominal force	250 N when frequency 50 Hz
Travel	10, 16 mm
Enclosure	IP 54
Process medium max. temperature	150°C
Ambient temperature range	-20 to 60°C
Ambient humidity range	5 - 100 % with condensation
Weight	1,5 kg

Wiring diagram of actuator

Voltage 230 V/50 Hz

Voltage 24 V/50 Hz

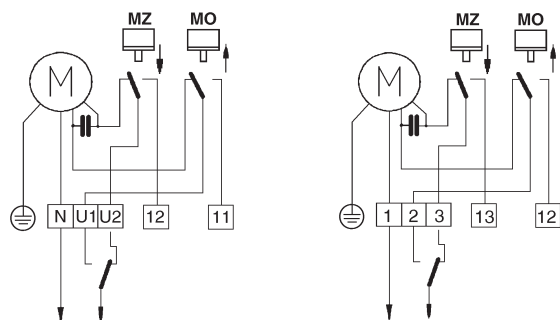

M electromotor
MO power switch for "OPEN" position
MZ power switch for "CLOSED" position

Dimensions of actuator PIKO 524 65

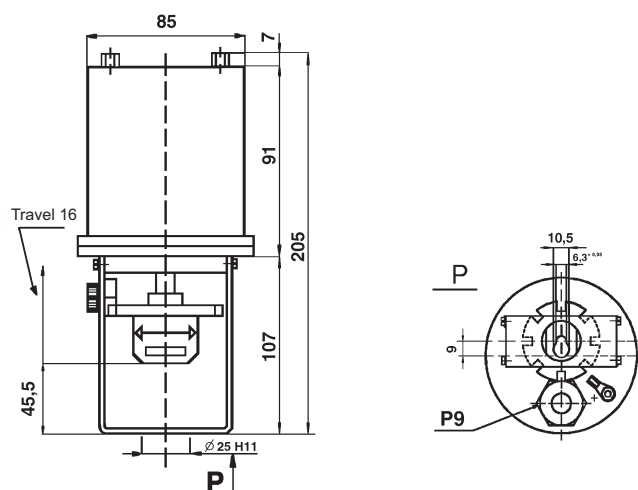

Specification of actuator PIKO 524 65

PIKO	524 65	X	X	X	X
Voltage	230 V / 50 Hz	0			
	24 V / 50 Hz	1			
Resetting speed	10 mm/min		2	0	
	20 mm/min		4	0	
Connection dimensions	LDM execution - max. draw bar stroke 16 mm				3



Electric actuators PTE 1 Ekorex

Technical data

Type	PTE 1 XXXX
Marking in valve specification No.	ERE
Voltage	24 V AC
Frequency	50 ± 2 Hz
Power consumption	Max. 3,5 VA
Control	Continuous
Nominal force	500 N
Travel	10, 16 mm
Enclosure	IP 54
Process medium max. temperature	150°C
Ambient temperature range	-20 to 60°C
Ambient humidity range	5 - 100 % with condensation
Weight	2 kg

Wiring diagram of actuator

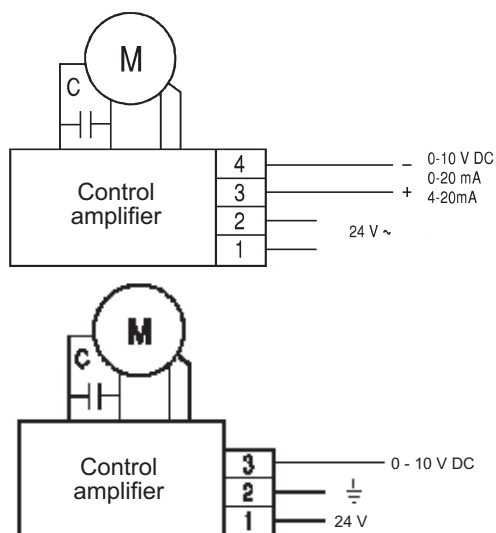

Dimensions of actuator PTE 1

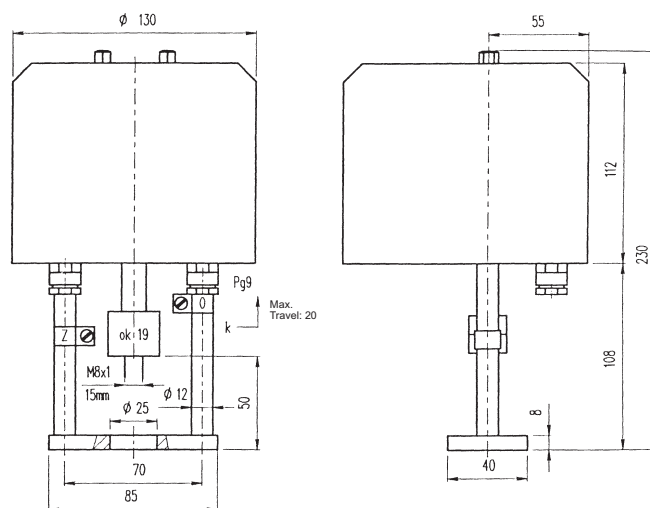

Specification of actuator PTE 1

PTE 1	X	X	X	X	Nominal force [N]	Resetting speed [mm.min ⁻¹]	Voltage
	0				500	10	24 V 50 Hz
	0				0 - 10 V DC	Control signal galvanically separated from feeding voltage	
	1				0 - 20 mA		
	2				4 - 20 mA		
	0				10	Draw bar stroke [mm]	
	1				16		
	0				Position Z up		
	1				Position Z down		



Electric actuator MIKRO 655 ZPA Nová Paka

Technical data

Type	Mikro 655 xxx
Marking in valve specification No.	ENA
Voltage	230 V or 24 V AC
Frequency	50/60 Hz
Power consumption	max. 6 (9) VA
Control	3 - position control, 0 - 10 V, 0(4) - 20 mA
Nominal force	600 and 1800 N
Travel	10, 16 mm
Enclosure	IP 65
Process medium max. temperature	Acc. to used valve
Ambient temperature range	-25 to 55°C
Ambient humidity range	10 - 100 % with condensation
Weight	2,7 kg

Wiring diagrams

3-position control, feeding voltage 230 V/50 Hz

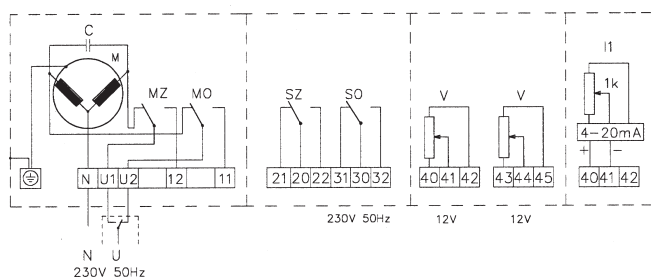

Control signal 0-10 V, 0(4)-20 mA, feeding voltage 230 V/50 Hz

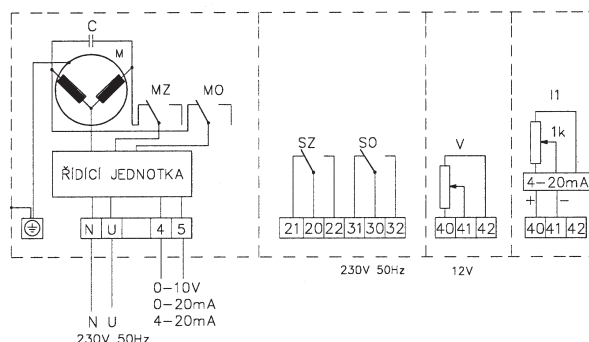

3-position control, feeding voltage 24 V/50 Hz

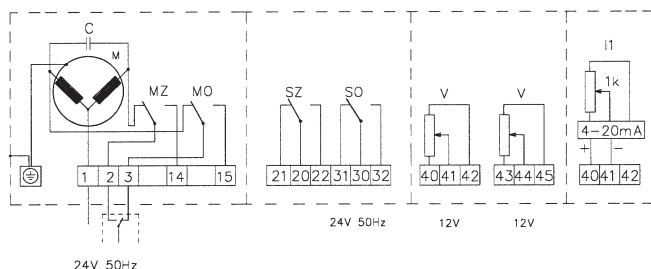

Control signal 0-10 V, 0(4)-20 mA, feeding voltage 24 V/50 Hz

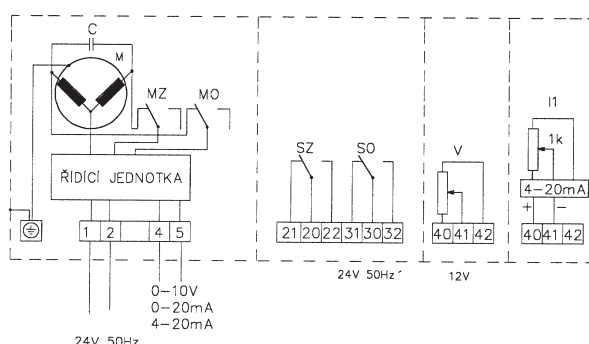

- MO power switch for position "Open"
- MZ power switch for position "Closed"
- SO signalization switch for position "Open"
- SZ signalization switch for position "Closed"
- M motor
- C capacitor
- V transmitter RP 16 100Ω
- I1 converter 4 - 20 mA for 2-wire conductor, connection to measuring loop (feeding directly from measured signal)

Specification of actuator MIKRO 655

		MIKRO 655	X	X	X	/
Feeding voltage AC	230 V (50/60 Hz)		1			
	24 V (50/60 Hz)		2			
Linear force [kN]	0,6			1		
	1,2			2		
Resetting speed [mm/min]	10			X	1	
	16			X	2	
	25			1	3	
	25			2	3	
Accessories	Positioner 0-1 V, 0-10 V, 0(4)-20 mA - without R2 and I1					OP1
	Signalization switches SO and SZ					S1
	1 resistance transmitter of 100Ω					R1
	2 resistance transmitter 100Ω - without OP1 and I1					R2
	Coverter 4 - 20 mA - without OP1 and R2					I1
	Connection flange $\varnothing 25$, coupling M8x1					P2

Basic execution: 3-position control, manual operating, limit switches for Open and Closed positions, without transmitter and connection elements.

Dimensions of actuator MIKRO 655

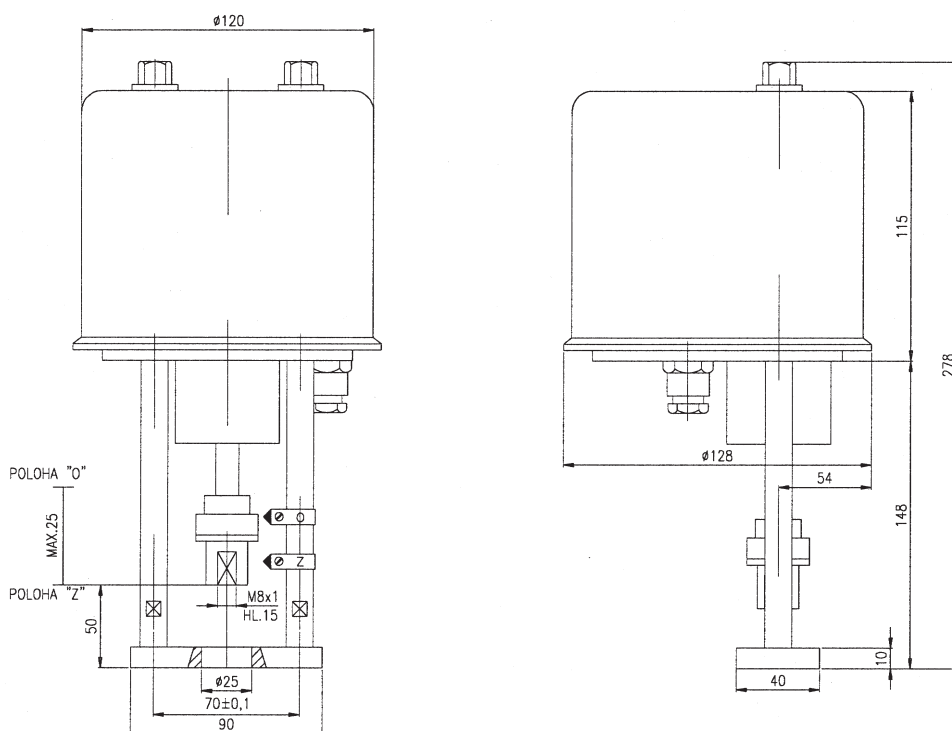



Electric actuator MIDI 660 ZPA Nová Paka

Technical data

Type	MIDI 660 XXX
Marking in valve specification No.	ENB
Voltage	230 V or 24 V AC
Frequency	50/60 Hz
Power consumption	max. 12 (18) VA
Control	3 - position control, 0 - 10 V, 0(4) - 20 mA
Nominal force	2000, 3200, 4000 N
Travel	16, 25 mm
Enclosure	IP 65
Process medium max. temperature	Acc. to used valve
Ambient temperature range	-25 to 55°C
Ambient humidity range	10 - 100 % with condensation
Weight	3,5 kg

Wiring diagrams

3-position control, feeding voltage 230 V/50 Hz

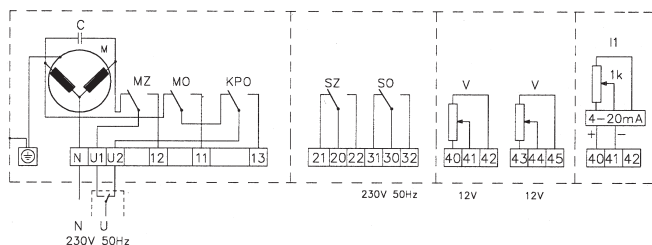

Control signal 0-10 V, 0(4)-20 mA, feeding voltage 230 V/50 Hz

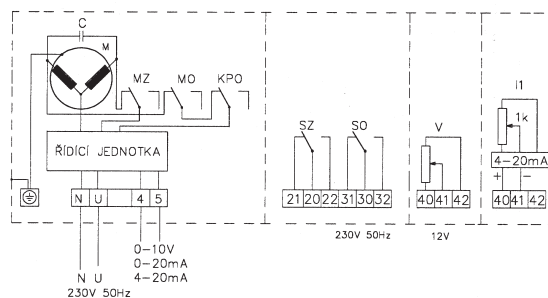

3-position control, feeding voltage 24 V/50 Hz

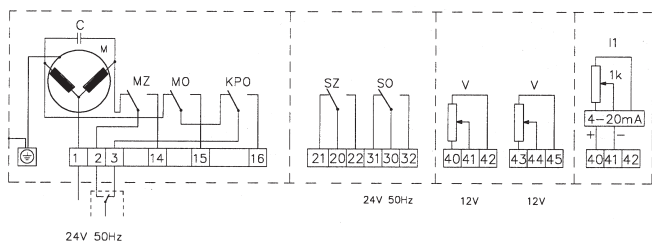

Control signal 0-10 V, 0(4)-20 mA, feeding voltage 24 V/50 Hz

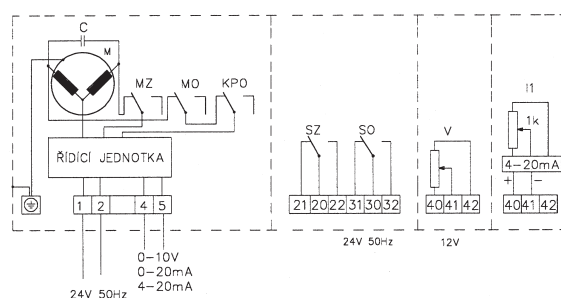

- KPO end position switch for position "Open"
- MO power switch for position "Open"
- MZ power switch for position "Closed"
- SO signalization switch for position "Open"
- SZ signalization switch for position "Closed"
- M motor
- C capacitor
- V transmitter RP 16 100Ω
- I1 converter 4 - 20 mA for 2-wire conductor, connection to measuring loop (feeding directly from measured signal)

Specification of actuator MIDI 660

		MIDI 660	X	X	X	/
Feeding voltage AC	230 V (50/60 Hz)		1			
	24 V (50/60 Hz)		2			
Linear force [kN]	2,0			1		
	3,2			3		
	4,0			4		
Resetting speed [mm/min]	10			X	1	
	16			X	2	
	25			X	3	
	32			1	4	
	32			3	4	
Accessories	Positioner 0-1 V, 0-10 V, 0(4)-20 mA					OP1
	Signalization switches SO and SZ					S1
	1 resistance transmitter 100Ω					R1
	2 resistance transmitters 100Ω - without OP1, I1 and C1					R2
	Converter 4 - 20 mA - without OP1, R2 and C1					I1
	Capacity transmitter CPT 1 - without R2 and I1					C1
	Manual operating outside the housing					RK1
Connection flange for $\varnothing 65$, coupling M10x1					P3	

Basic execution : 3-position control, manual operating, limit switches for Open and Closed positions, without transmitter and connection elements.

Dimensions of actuator MIDI 660

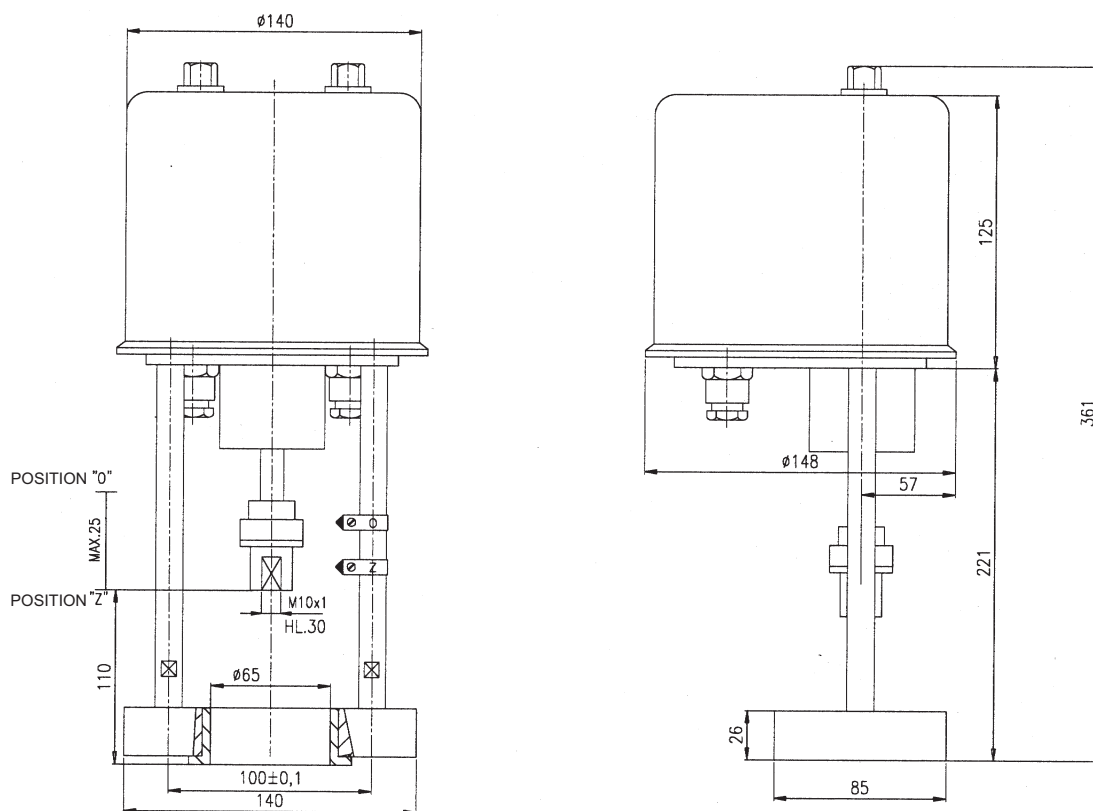



Electric actuators PTN 1 Ekorex

Technical data

Type	PTN 1 XXXXXXXXX
Marking in valve specification No.	ERA
Voltage	230 V or 24 V AC
Frequency	50 ± 2 Hz
Power consumption	8 VA
Control	3 - position control; 4 - 20 mA; 0 - 10 V; 0 - 20 mA
Nominal force	600 N, 1200 N
Travel	10, 16 mm
Enclosure	IP 54
Process medium max. temperature	150°C
Ambient temperature range	-20 to 60°C
Ambient humidity range	5 - 100 % with condensation
Weight	2,5 kg

Wiring diagram of actuator PTN 1

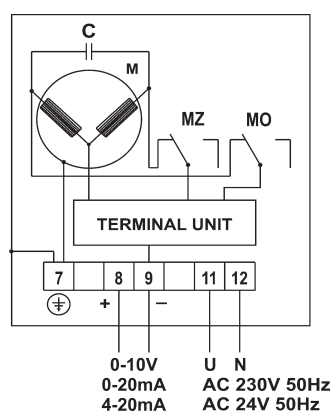
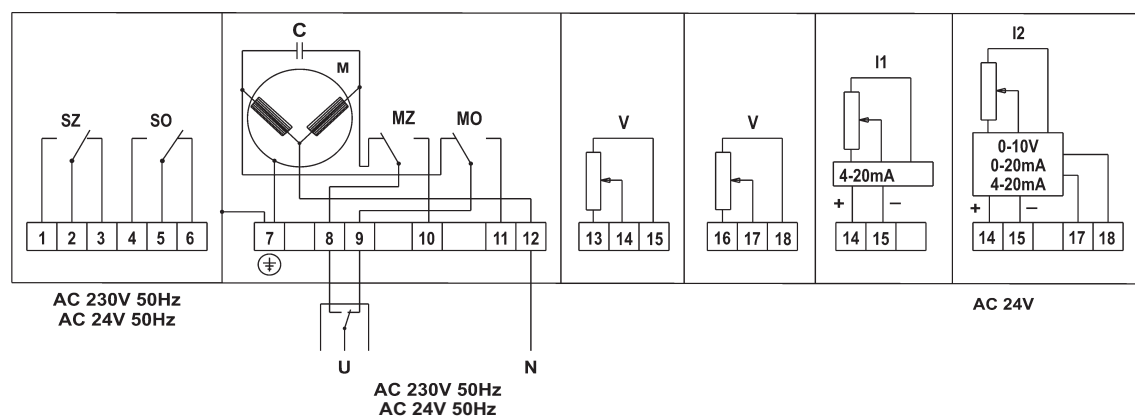

- MO - power switch for "OPEN" position
- MZ - power switch for "CLOSED" position
- SO - signalisation switch for "OPEN" position
- SZ - signalisation switch for "CLOSED" position
- M - motor
- C - capacitor
- V - resistance transmitter 100 Ω
- I1 - resistance transmitter with convertor 4-20 mA - 2-wire execution
- I2 - resistance transmitter with convertor - separate feeding 24V AC

WARNING: In case of using valves RV 102, RV 103 is position "closed" up (switch MO)

Specification of actuator PTN 1

PTN 1	X	X	X	X	X	X	X	X	Nominal force [N]	Resetting speed [mm.min ⁻¹]
	1	1							600	10
	1	2							600	16
	1	3							600	25
	2	1							1200	10
	2	2							1200	16
	2	3							1200	25
	0							230 V, 50 Hz	Motor supply voltage (AC)	
	2							24 V, 50 Hz		
	0							MO; MZ	Number of microswitches	
	2							MO; MZ; SO; SZ		
	0							Without equipment		
	1							Output 0 - 10 V	Independent feeding voltage 24 V	
	2							Output 0 - 20 mA		
	3							Output 4 - 20 mA		
	4							Output 4 - 20 mA	2 - wire connection	
	5							Output 0 - 100 Ω 1x	Resistance output signal	
	6							Output 0 - 100 Ω 2x		
	2							10	Draw bar stroke [mm]	
	3							16		
	1	0						Flange with columns	Clutch M 8x1	

NOTE:

Table applies to actuator with 3-position control.

It is possible to supply actuator with control signal of 0 - 10 V, 0 - 20 mA, 4 - 20 mA (example of marking: PTN 1 - XX.XX.XX.XX / control signal 4 - 20 mA)

Dimensions of actuator PTN 1

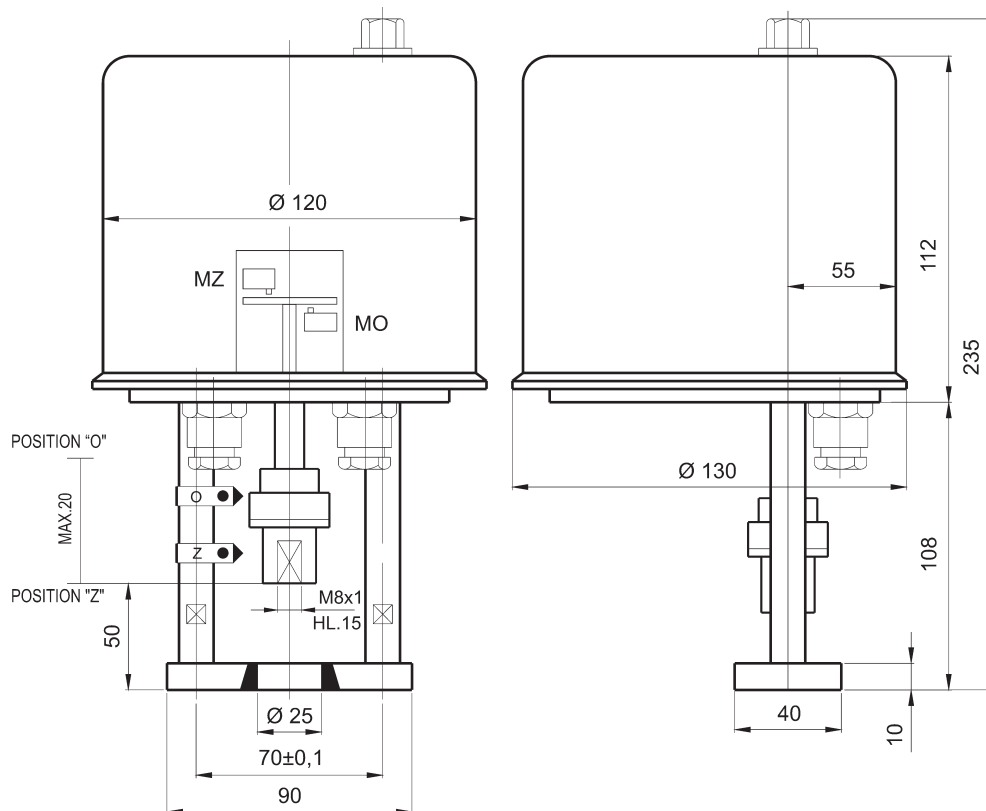



Electric actuators PTN 2 Ekorex

Technical data

Type	PTN 2.20	PTN 2.32	PTN 2.40
Marking in valve specification No.	ERB	ERC	ERC
Voltage	230 V + 6 %, -12 % or 24 V + 10 %, -15 % AC		
Frequency	50 Hz		
Power consumption	Max. 19 VA		
Control	3 - position control, (0) 4 - 20 mA, 0 - 10 V		
Nominal force	2000 N	3200 N	4000 N
Travel	Max. 25 mm		
Enclosure	IP 65		
Process medium max. temperature	Acc. to used valve		
Ambient temperature range	-20 to 60°C (weather-resistant design -45 to 60°C)		
Ambient humidity range	5 to 100 % with condensation		
Weight	4 kg		

Wiring diagram of actuator

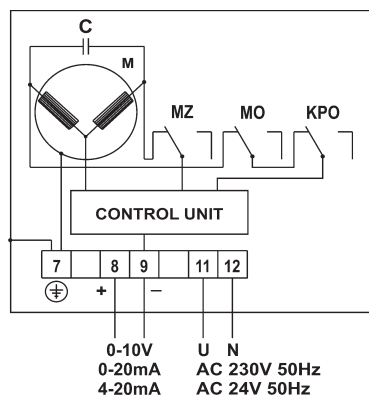
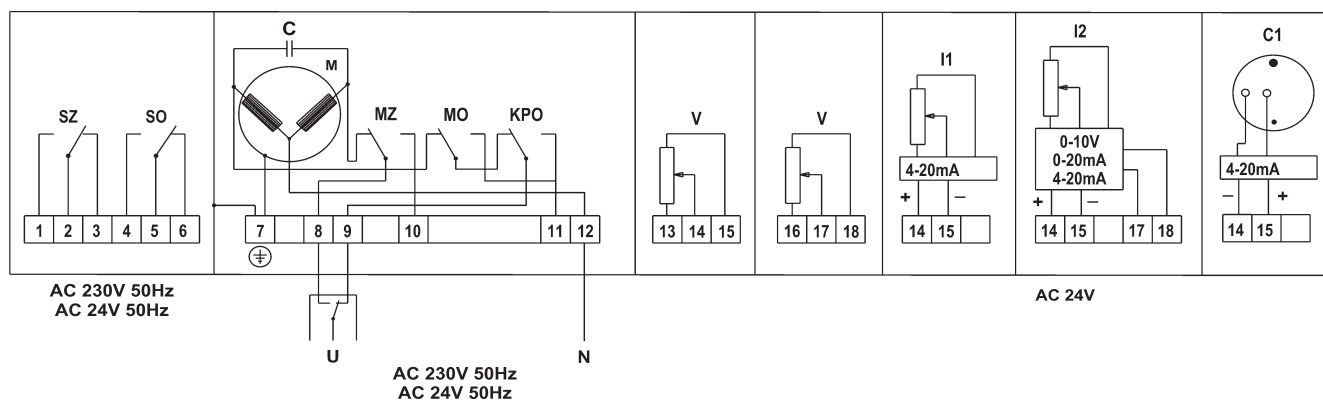

- MO - power switch for "OPEN" position
- MZ - power switch for "CLOSED" position
- SO - signalisation switch for "OPEN" position
- SZ - signalisation switch for "CLOSED" position
- KPO - terminal position switch for "OPEN" position
- M - motor
- C - capacitor
- V - resistance transmitter 100 Ω
- I1 - resistance transmitter with convertor 4-20 mA - 2-wire execution
- I2 - resistance transmitter with convertor - separate feeding 24V AC
- C1 - capacitive transmitter with convertor 4-20 mA

WARNING: In case of using valves RV 102, RV 103 is position "closed" up (switch MO)

Specification of actuator PTN 2

PTN 2	X	X	X	X	X	X	X	X	Nominal force [kN]	Resetting speed [mm/min ¹]	
	2	0							2	10, 16, 25, 32	
	3	2							3,2	10, 16, 25, 32	
	4	0							4	10, 16, 25	
		0							230 V, 50 Hz	Motor supply voltage (AC)	
		2							24 V, 50 Hz		
			1						10	Resetting speed [mm.min ⁻¹]	
			2						16		
			3						25		
			4						32		
			0						Without equipment	Independent feeding 24 V	
			1						Output 0 - 10 V		
			2						Output 0 - 20 mA		
			3						Output 4 - 20 mA		
			4						Output 4 - 20 mA		
			5						Output 0 - 100 Ω 1x		
			6						Output 0 - 100 Ω 2x	Resistance output signal	
			1						Flange with columns	Pitch 70 mm	Clutch M 8x1
			3						Flange with columns	Pitch 100 mm	Clutch M 10x1
			0						MO; MZ	Number of microswitches	
			2						MO; MZ; SO; SZ		
			4						MO; MZ; KPO		
			6						MO; MZ; SO; SZ; KPO		
			9						According to agreement		
			2					10	Draw bar stroke [mm]		
			3					16			
			5					25			

NOTE:

Table applies to actuator with 3-position control.

It is possible to supply actuator with control signal of 0 - 10 V, 0 - 20 mA (code /DMS 3), 4 - 20 mA s ručním ovládání vně skříně (/RO) nebo verzi se zvýšenou klimatickou odolností -45°C to 60°C (/KO)

(example of marking: PTN 2 - XX.XX.XX.XX / control signal 4 - 20 mA)

(příklad označení v typovém čísle: PTN 2 - XX.XX.XX.XX /DMS 3 4 - 20 mA / RO /KO)

Dimensions of actuator PTN 2

Connection to valves RV 102, RV 103

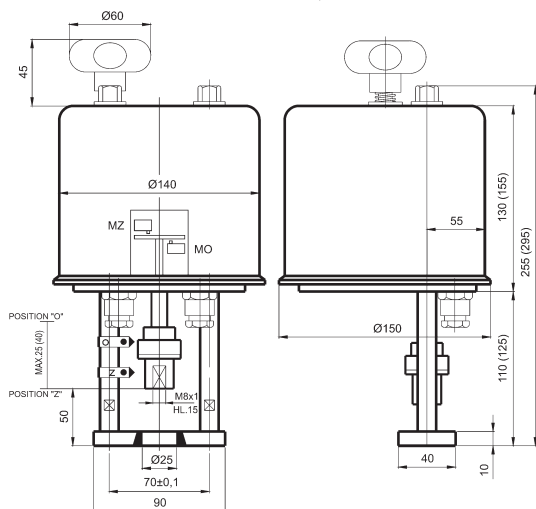

Connection to valves RV / UV 2x0, RV 2x2, RV 2x4

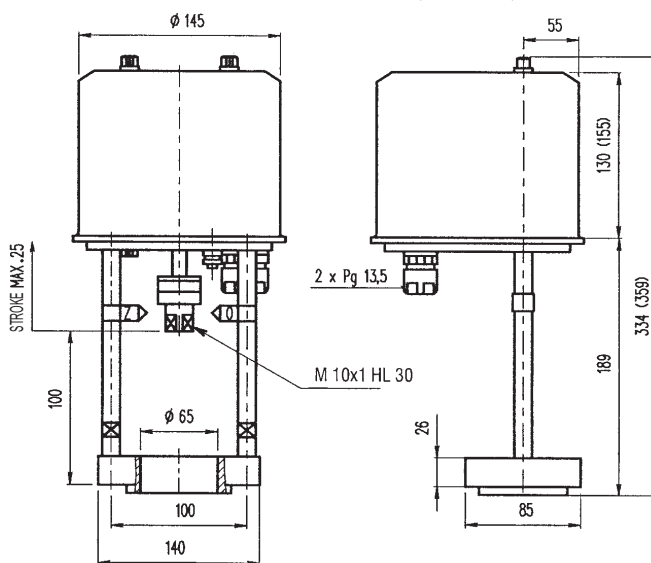



Electric actuators PTN 6 Ekorex

Technical data

Type	PTN 6 XX.XX.XX.XX
Marking in valve specification No.	ERD
Voltage	230 V + 6%, - 12% or 24 V + 10%, -15% AC
Frequency	50 Hz
Power consumption	max. 39 VA
Control	3 - position control, continuous with positioner
Nominal force	6300 N or 10 000 N
Travel	16, 25 and 40 mm
Enclosure	IP 65
Process medium max. temperature	Acc. to used valve
Ambient temperature range	-20 to 60°C
Ambient humidity range	5 - 100 % with condensation
Weight	7 kg
Hand wheel	As standard equipment of actuator

Wiring diagram of actuator

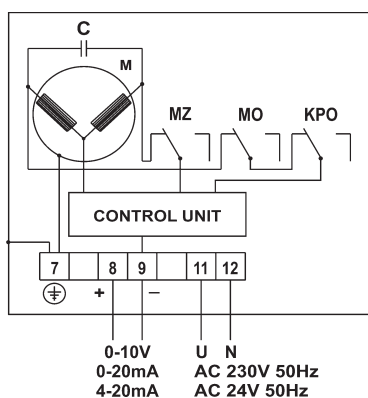
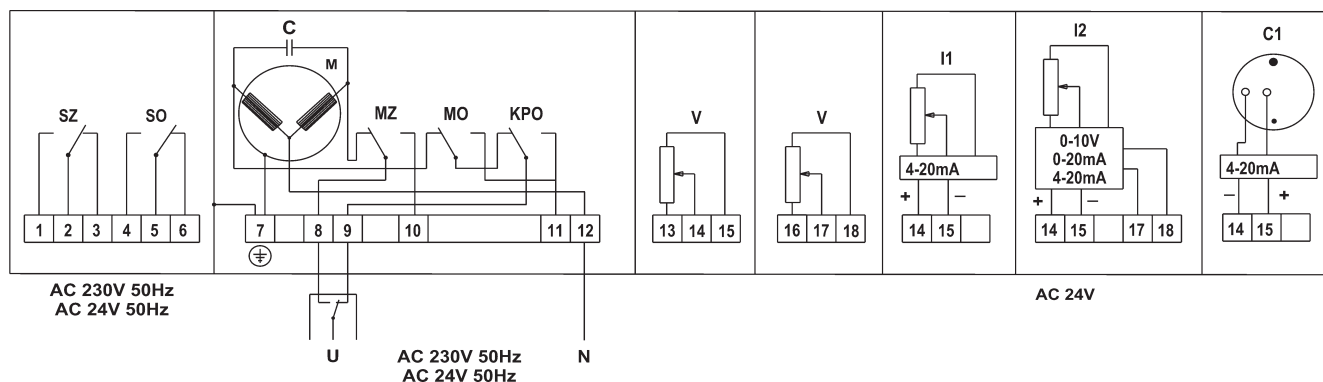

- MO - power switch for "OPEN" position
- MZ - power switch for "CLOSED" position
- SO - signalisation switch for "OPEN" position
- SZ - signalisation switch for "CLOSED" position
- KPO - terminal position switch for "OPEN" position
- M - motor
- C - capacitor
- V - resistance transmitter 100 Ω
- I1 - resistance transmitter with convertor 4-20 mA - 2-wire execution
- I2 - resistance transmitter with convertor - separate feeding 24V AC
- C1 - capacitive transmitter with convertor 4-20 mA

Specification of actuator PTN 6

PTN 6	X	X	X	X	X	X	X	X				
	6	3							6,3			
	1	0							10		Nominal force [kN]	
			0						230 V, 50 Hz		Motor supply voltage (AC)	
			2						24 V, 50 Hz			
				1					10		Resetting force [mm.min ⁻¹]	
				2					16			
				3					20			
				4					25			
				5					32			
				6					50			
				0					Without equipment		Independent feeding 24 V	
				1					Output 0 - 10 V			
				2					Output 0 - 20 mA			
				3					Output 4 - 20 mA			
				4					Output 4 - 20 mA	2 - wire connection		
				5					Output 0 - 100 Ω	1x		Resistance output signal
				6					Output 0 - 100 Ω	2x		
				7					Output of capacity transmitter 4 - 20 mA			
				1					Flange with columns M20	Pitch 132 mm	Clutch M 10x1	
				2					Flange with columns M20	Pitch 132 mm	Clutch M 16x1,5	
				0					MO; MZ		Number of microswitches	
				2					MO; MZ; KPZ			
				5					MO; MZ; KPO			
				6					MO; MZ; SO; SZ; KPO			
					4				16		Draw bar stroke [mm]	
					5				25			
					7				40			

NOTE:

Table applies to actuator with 3-position control.

It is possible to supply actuator with control signal of 0 - 10 V, 0 - 20 mA, 4 - 20 mA
(example of marking: PTN 6 - XX.XX.XX.XX / control signal 4 - 20 mA)

Dimensions of actuator PTN 6

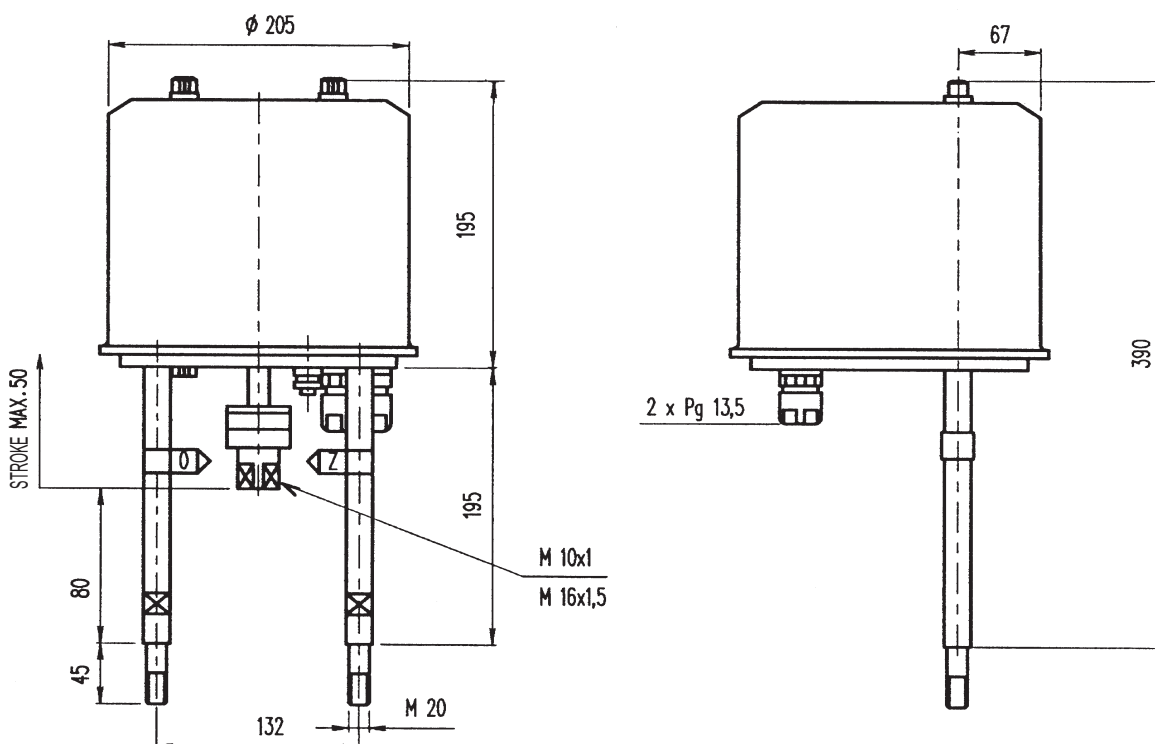



Electric actuators PTN 7 Ekorex

Technical data

Type	PTN 7 XX.XX.XX.XX
Marking in valve specification No.	ERG
Voltage	230 V or 24 V 24 V \pm 10 % (AC)
Frequency	50 Hz
Power consumption	max. 120 VA, heat resistor max. 9A
Control	3 - position control, continuous with positioner
Nominal force	16000 N or 20000 N
Travel	40, 80 mm
Enclosure	IP 65
Process medium max. temperature	Acc. to used valve
Ambient temperature range	-20 to 60°C
Ambient humidity range	10 - 100 % with condensation
Weight	10 kg
Hand wheel	As standard equipment of actuator

Wiring diagram of actuator

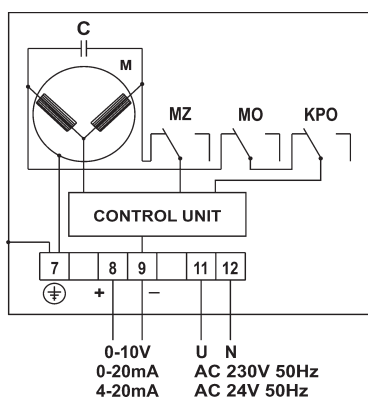
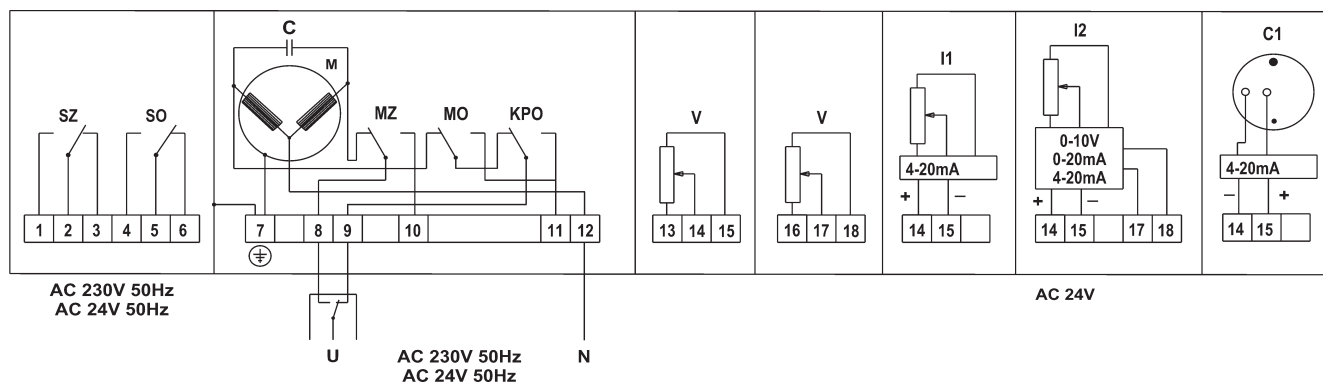

- MO - power switch for "OPEN" position
- MZ - power switch for "CLOSED" position
- SO - signalisation switch for "OPEN" position
- SZ - signalisation switch for "CLOSED" position
- KPO - terminal position switch for "OPEN" position
- M - motor
- C - capacitor
- V - resistance transmitter 100 Ω
- I1 - resistance transmitter with convertor 4-20 mA - 2-wire execution
- I2 - resistance transmitter with convertor - separate feeding 24V AC
- C1 - capacitive transmitter with convertor 4-20 mA

Specification of actuator PTN 7

PTN 7	X	X	X	X	X	X	X	X		
	1								16	Nominal force [kN]
	2								20	
	9								Acc. to contract	
	1								20	Resetting force [mm.min ⁻¹]
	2								25	
	3								32	
	4								50	
	5								80 (for 16 kN only)	
	0								230 V, 50 Hz, 60 Hz	Motor supply voltage At 60 Hz is the speed increased for 20%
	2								24 V, 50 Hz, 60 Hz	
	2								MO; MZ; KPO	Number of microswitches
	6								MO; MZ; SO; SZ; KPO	
	9								Acc. to contract	
	0								Without equipment	Independent feeding 24 V (AC)
	1								Output 0 - 10 V	
	2								Output 0 - 20 mA	
	3								Output 4 - 20 mA	
	4								Output 4 - 20 mA	
	5								Output 0 - 100 Ω 1x	Resistance output signal
	6								Output 0 - 100 Ω 2x	
	7								Output of capacity transmitter 4 - 20 mA	2 - wire connection
	9								Acc. to contract	
	2								40	Draw bar stroke [mm]
	6								80	
	1 0								Columns M20, clutch M16x1,5 (for valves DN 80 - 150, H = 40 mm)	
	3 0								Columns M20, clutch M20x1,5 (for valves DN 200 - 300, H = 80 mm)	

Note:

Table applies to actuator with 3-position control.

It is possible to supply actuator with control signal of 0 - 10 V, 0 - 20 mA, 4 - 20 mA and manual operation outside the cover (example of marking: PTN 7 - XX.XX.XX.XX / control signal 4 - 20 mA / RO)

Dimensions of actuator PTN 7

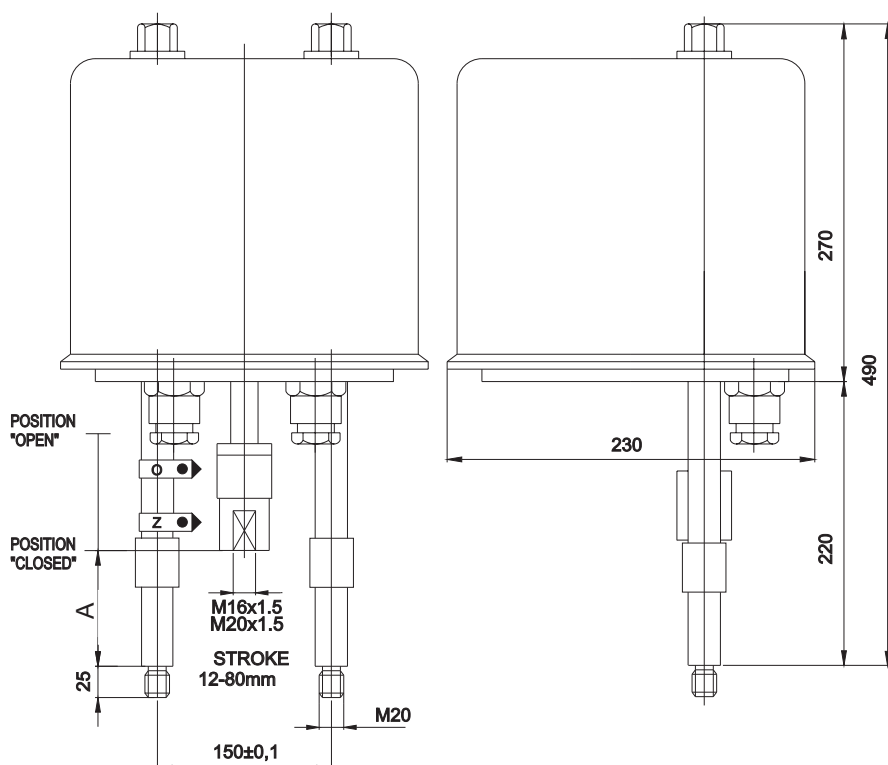

Connection	A
1	74
3	140



Electric actuator Zepadyn 670 ZPA Nová Paka

Technical data

Type	Zepadyn 670 XXX
Marking in valve specification No.	ENC
Voltage	230 V or 24 V AC
Frequency	50 Hz
Power consumption	40 VA
Control	3 - position control, 0 - 10 V, 0(4) - 20 mA
Nominal force	6300 and 10000 N
Travel	16, 25, 40 mm
Enclosure	IP 65
Process medium max. temperature	Acc. to used valve
Ambient temperature range	-25 to 55°C
Ambient humidity range	10 - 100 % with condensation
Weight	11 kg

Wiring diagram of actuator

3-position control, feeding voltage 230 V/50 Hz

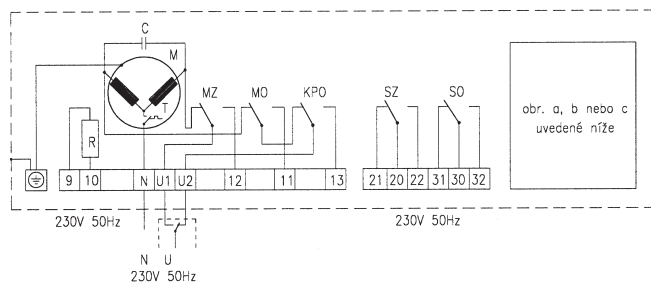

Version with positioner, feeding voltage 230 V/50 Hz

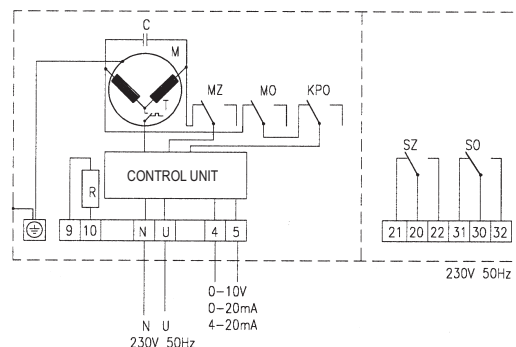

3-position control, feeding voltage 24 V/50 Hz

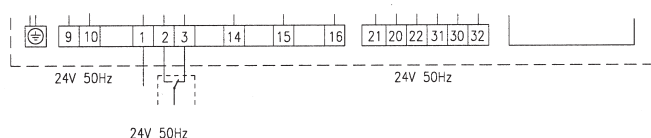

Version with positioner, feeding voltage 24 V/50 Hz

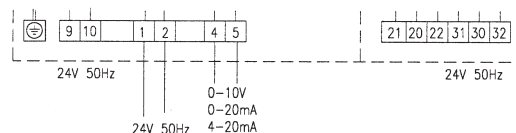

Execution:
with resistance transmitter with capacity transmitter

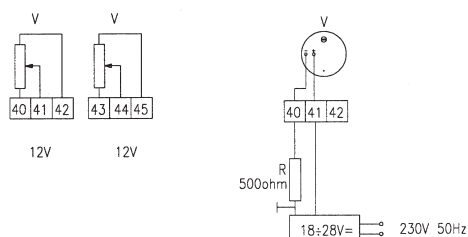

with converter
4-20mA

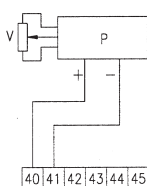

MO power switch for position "Open"
 MZ power switch for position "Closed"
 SO signalization switch for position "Open"
 SZ signalization switch for position "Closed"
 KPO end position switch for position "Open"
 V transmitter
 R heater
 M motor type FCJ2B52D-00
 C capacitor TC 846 S 60μF (2x)
 P converter 4 - 20 mA for 2-wire conductor, connection to measuring loop (feeding directly from measured signal)

Specification of Zepadyn 670

		Zepadyn 670	X	X	X	/
Voltage AC	230 V (50/60 Hz)		1			
	24 V (50/60 Hz)		2			
Nominal force [kN]	6,3			2		
	10			4		
Resetting speed mm.min ⁻¹	6,3				1	
	16				2	
	25				3	
	32 (not on execution with OP1)				4	
Accessories	Positioner 0-1 V, 0-10 V, 0(4)-20 mA - without R2					OP1
	Signalization SO a SZ					S1
	1 resistance transmitter 100Ω					R1
	2 resistance transmitters 100Ω - without OP1, I1 and C1					R2
	Converter 4 - 20 mA - without R2 and C1					I1
	Capacity transmitter CPT1 - without R2 and I1					C1
	Heater					T1
	Connection - pitch 132, M20, coupling M10x1, M16x1,5					P3
Adapter with setting program for actuators with OP1					ANP1	
Stroke for valve - xx = 16, 20, 25, 32, 40, 52 mm						ZDxx

Basic execution: 3-position control, manual operating, limit switches for Open and Closed positions and end position switch without transmitter and connection elements.

Dimensions of Zepadyn 670

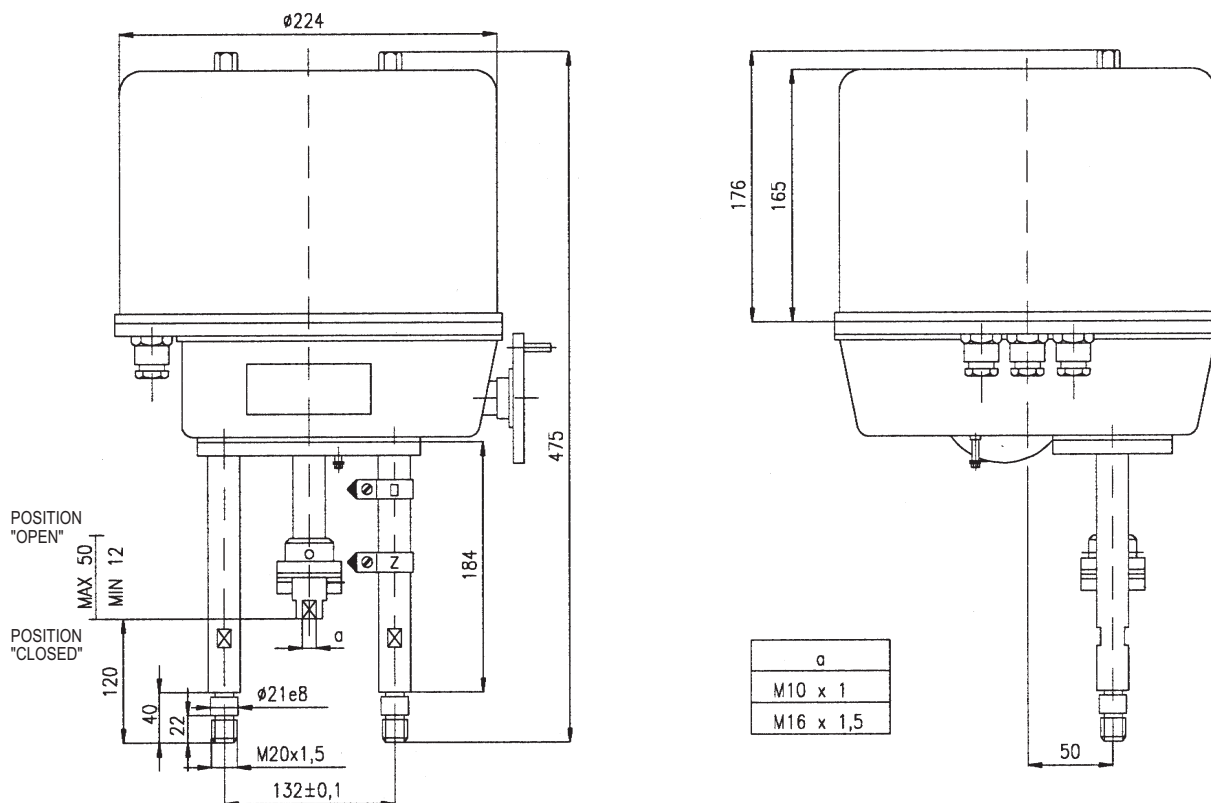



Electric actuator Zepadyn 671 ZPA Nová Paka

Technical data

Type	Zepadyn 671 XXX
Marking in valve specification No.	ENE
Voltage	230 V AC or 24 V AC
Frequency	50 Hz
Power consumption	max 120 VA, heat resistor 15 W
Control	3 - position control, 0 - 10 V, 0(4) - 20 mA
Nominal force	16000 and 20000 N
Travel	max. 80 mm
Enclosure	IP 65
Process medium max. temperature	Acc. to used valve
Ambient temperature range	-25 to 55°C
Ambient humidity range	10 - 100 % with condensation
Weight	12,5 kg

Note:

Detail technical informations can be found in producer's data sheet or on thr webside www.zpanp.cz

Specification of Zepadyn 671

		Zepadyn 671				X	X	X	/
Voltage AC	230 V (50/60 Hz)				1				
	24 V (50/60 Hz)				2				
Nominal force [kN]	16					1			
	20					2			
Resetting speed mm.min ⁻¹	16						1		
	25						2		
	32						3		
	50						4		
Accessories	Positioner 0-1 V, 0-10 V, 0(4)-20 mA - without R2 and I1								OP1
	Signalization SO a SZ								S1
	1 resistance transmitter 100Ω								R1
	2 resistance transmitters 100Ω - without OP1, I1 and C1								R2
	Converter 4 - 20 mA - without R2 and C1								I1
	Capacity transmitter CPT1 - without R2 and I1								C1
	Heater								T1
	Connection - pitch 150, M20, coupling M16x1,5								P3
	Connection - pitch 150, 4 columns M20, coupling M20x1,5								P5
	Adapter with setting program for actuators with OP1								ANP1
Stroke for valve - xx = 40, 80 mm								ZDxx	

Basic execution: 3-position control, manual operating, limit switches for Open and Closed positions and end position switch without transmitter and connection elements.

* Connection for LDM valves

P3	RV 2xx DN 80 - 150
P5	RV 2xx DN 200 - 300

Wiring diagram of actuator Zepadyn 671

- a) execution with resistance transmitter
- b) execution with position capacitive transmitter
- c) execution with convertor 4 - 20 mA

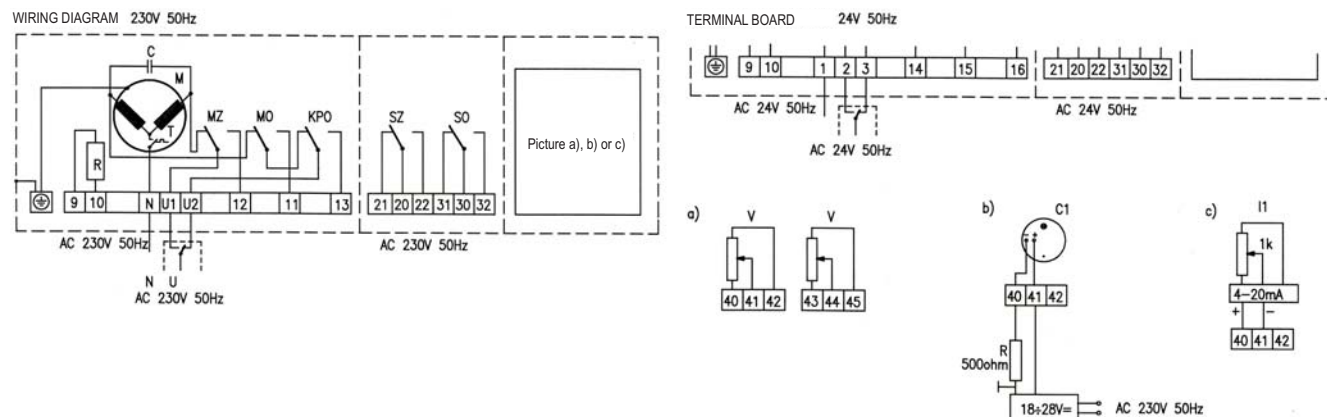

Control 0-10 V, 0 - 20 mA, 4 - 20 mA

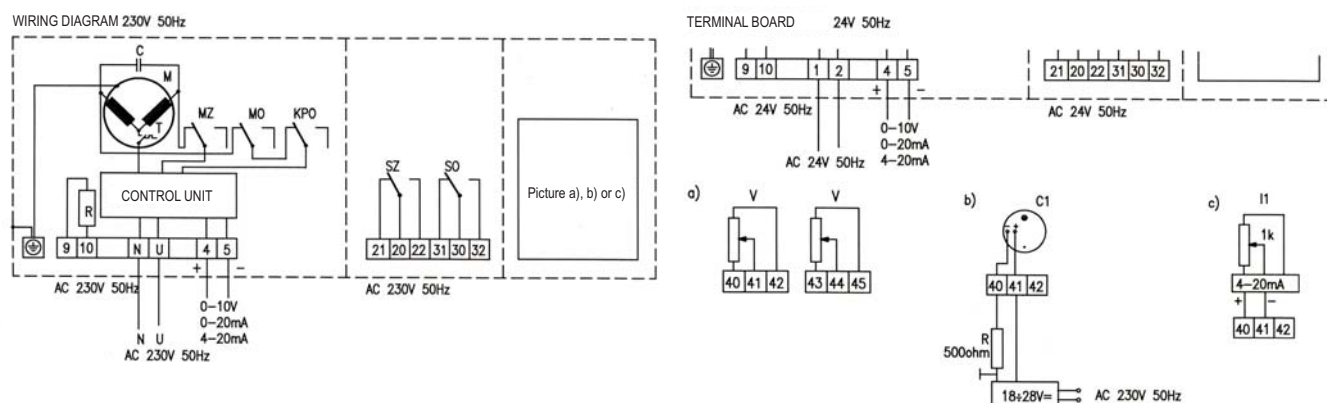

- KPO end position switch for position "Open"
- MO power switch for position "Open"
- MZ power switch for position "Closed"
- SO signalization switch for position "Open"
- SZ signalization switch for position "Closed"
- V transmitter
- R heater
- M motor
- C capacitor
- I1 converter 4 - 20 mA for 2-wire conductor, connection to measuring loop (feeding directly from measured signal)
- C1 capacitive transmitter with convertor 4-20 mA

Dimensions of actuator Zepadyn 671

Connection P3 - pitch 150; 2 columns M20; clutch M16x1,5; stroke 12...62

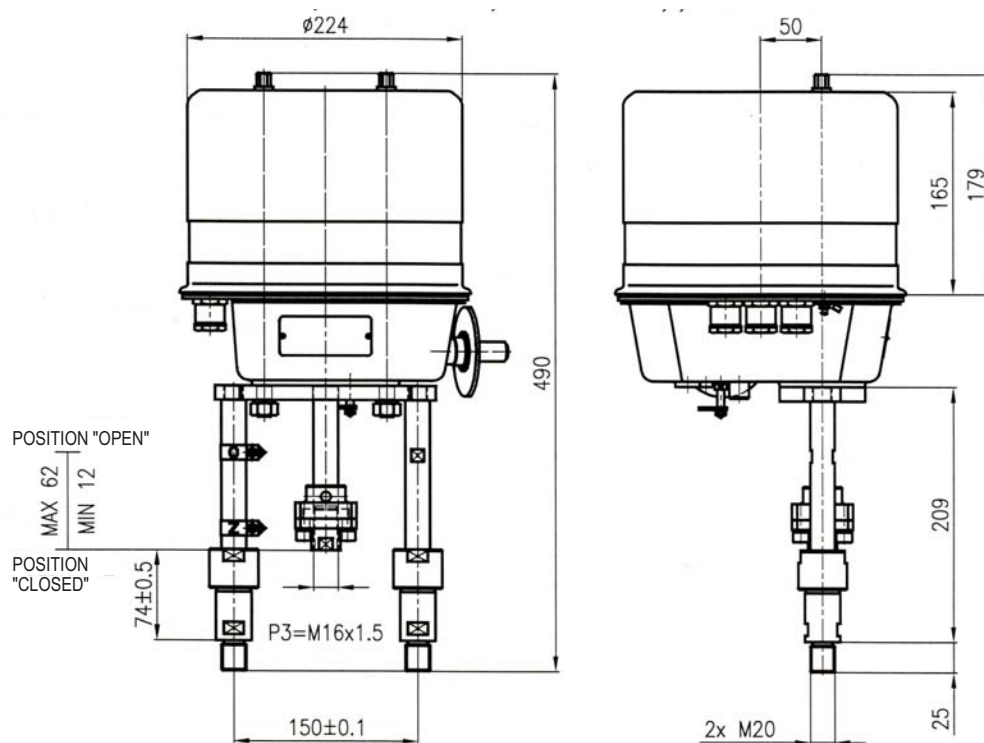

Connection P5 - pitch 150; 4 columns M20; clutch M20x1,5; stroke 80

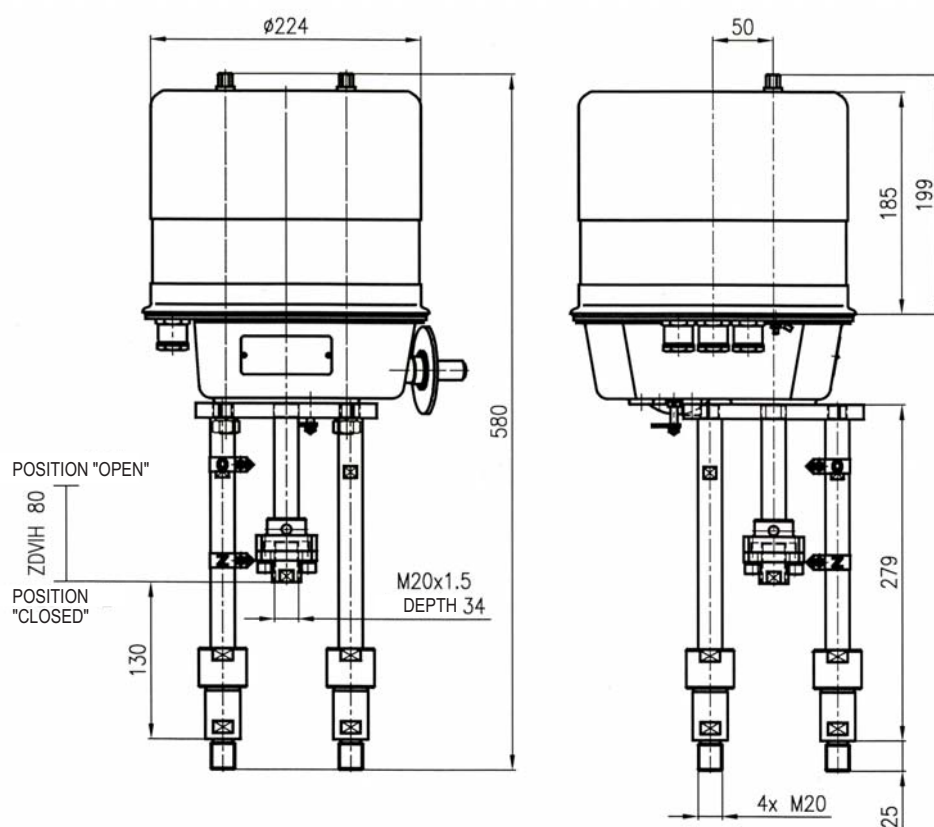



EYA
EYB

**Electric actuators Modact MTN, MTP
and Modact MTN, MTP Control, type 52 442
ZPA Pečky**

Technical data

Type	Modact MTN Control	Modact MTN	Modact MTP Control	Modact MTP
Marking in valve specification No.	EYA	EYB	EYA	EYB
Voltage	3 x 230 V / 400 V AC			
Frequency	50 Hz			
Motor power	See specification table			
Control	3 - position, with regulator ZP2.RE5			
Nominal force	11500 to 25000 N			
Travel	10 to 100 mm			
Enclosure	IP 55		IP 65	
Process medium max. temp.	Acc. to used valve			
Ambient temperature range	-25 to 55°C			
Ambient humidity range	5 - 100 % with condensation			
Weight	33 kg			

Wiring diagram of actuators *)

*) Detail technical informations and wiring diagrams can be found in producer's datasheet or on the website www.zpa-pecky.cz.

Specification of actuators Modact MTN, MTP and Modact MTN, MTP Control

Basic equipment	2 power switches MO, MZ 2 limit switches PO, PZ 2 limit and signalisation switches SO, SZ	1 position transmitter - resist. 2x100 Ω or current 2 limit switches PO, PZ 2 limit and signalisation switches SO, SZ
-----------------	---	---

Basic technical parameters

Type	Power switch setting range kN	Direct power kN	Resetting speed mm.min ⁻¹	Travel mm	Power W	Electromotor MTN			Electromotor MTP			Weight Aluminium [kg]	Specification No.	
						rpm 1/min	In (400V) A	Iz In	rpm 1/min	In (400V) A	Iz In		Basic	Additional ²⁾
MTN 15 MTP 15	11,5 - 15	17	50	10 - 100	180	850	0.74	2.3	835	0.62	2.3	33	52 442	XX0XXM
			80		180	850	0.74	2.3	835	0.62	2.3			XX1XXM
			125		250	1350	0.77	3.0	1350	0.76	3.0			XX3XXM
			36		120	645	0.51	2.2	645	0.51	2.2			XX2XXM
			27		120	645	0.51	2.2	645	0.51	2.2			XXAXXM
MTN 25 MTP 25	15 - 25	32,5	50	10 - 100	180	835	0.74	2.3	835	0.62	2.3	33		XX4XXM
			80		180	835	0.74	2.3	835	0.62	2.3			XX5XXM
			125		250	1350	0.77	3.0	1350	0.76	3.0			XX6XXM
			36		120	645	0.51	2.2	645	0.51	2.2			XX7XXM
			27		120	645	0.51	2.2	645	0.51	2.2			XX8XXM

Execution, electric connection

Via terminal board	6XXXXM
With conector HARTING	7XXXXM
Execution Modact MTN; Modact MTN Control ... enclosure IP55	XXXXNM
Execution Modact MTP; Modact MTP Control ... enclosure IP67	XXXXPM

		Current transmitter CPT without source	Current transmitter DCPT with source
Position transmitter	current 4 - 20 mA	XXX0XM	XXXRXM
	current 4 - 20 mA with BMO	XXX1XM	XXXSXM
	resistance transmitter 2x 100 Ω	XXX2XM	
	resistance transmitter 2x 100 Ω s BMO	XXX3XM	
	without transmitter, with BMO	XXXPXM	
	without transmitter, without BMO	XXXZXM	

Additional electric equipment ¹⁾

		Resistance transmitter 2x 100 ohm	Current transmitter CPT without source	Current transmitter DCPT with source	
Modact Control execution (with built-in contactor combination)	without BMO	Without brake BAM and positioner	XXX4XM	XXXKXM	
		With brake BAM, without positioner	XXX5XM	XXXLXM	
		With brake BAM and with positioner		XXXCX5M ³⁾	
	with BMO	Without brake BAM and positioner	XXX7XM	XXXDXM	XXXMXM
		With brake BAM, without positioner	XXX8XM	XXXEXM	XXXNXM
		With brake BAM and with positioner		XXXFX5M ³⁾	

Notes:

- ¹⁾ When execution with flasher is requested, specify this requirement in writing: Execution with flasher
- ²⁾ Design without force locking after reversion have at end position capital letter M (for example: 52442.6211NM)
- ³⁾ For actuators MODACT MTN Control s with position controllers ZP2.RE5 specify number 5 on place 11

Connection dimensions - details of additional specification No. 52 442

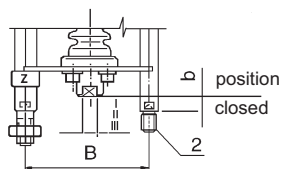

Pitch of columns	B	150
Position "closed"	b	74
	g	130
	I	M 20x1,5
Clutch thread	II	M 16x1,5
	III	M 10x1

Execution	Specification No.		For valves
	basic	additional	
Bb2I	52 442	XLXXXM	---
Bb2II	52 442	XMXXXM	RV 2xx DN 80 to 150
Bb2III	52 442	XPXXXM	RV 2xx DN 15 to 65
Bg2I	52 442	XRXXXM	RV 2xx DN 200 to 400

Dimensions of actuator Modact MTN, MTP

- with terminal board

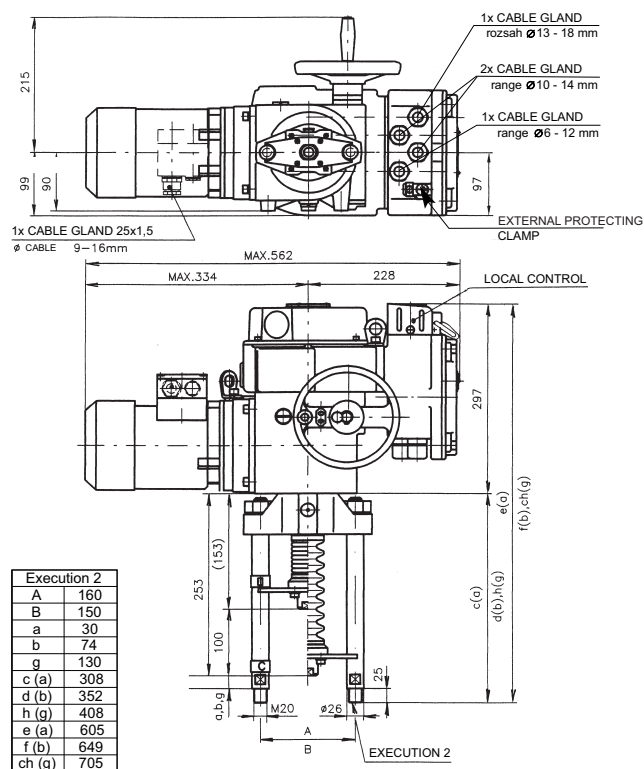

Dimensions of actuator Modact MTN, MTP and Modact MTN, MTP Control

- with conector

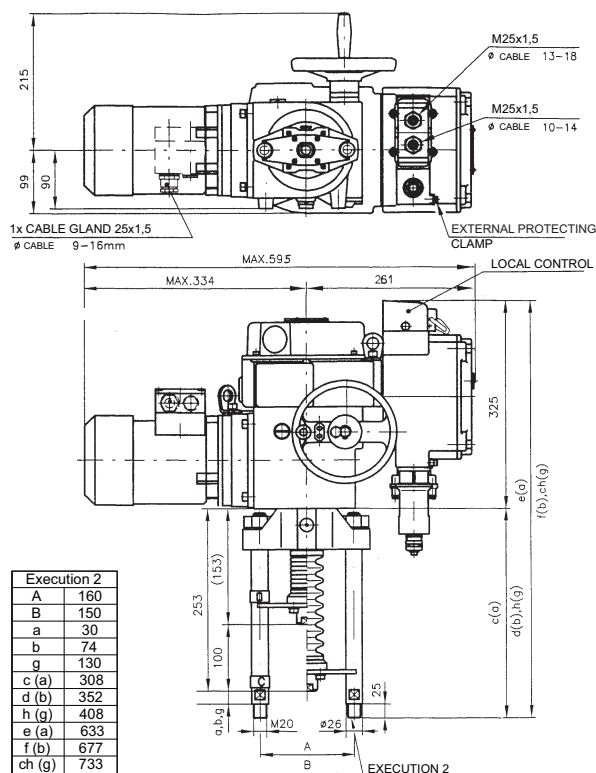

Dimensions of actuator Modact MTN, MTP Control

- with terminal board

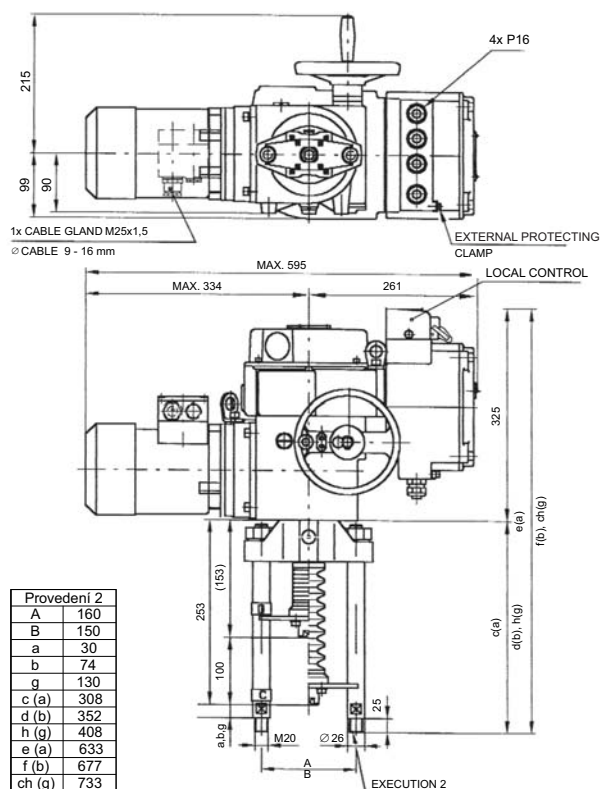

Detail of coupling

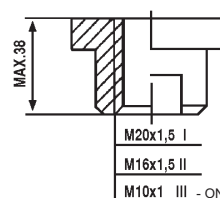



Electric actuators Modact MTNED and Modact MTPED, typ 52 442 ZPA Pečky

Technical data

Type	Modact MTNED	Modact MTPED
Marking in valve specification No.	EYA	
Execution	The actuator equipped with electronic system DMS2 or DMS2 ED	
Voltage	3 x 230 V / 400 V AC	
Frequency	50 Hz	
Motor power	See specification table	
Control	3 - position, or continuous	
Nominal force	11500 to 25000 N	
Travel	10 to 100 mm	
Enclosure	IP 55	IP 65
Process medium max. temp.	Acc. to used valve	
Ambient temperature range	-25 to 55°C	
Ambient humidity range	5 - 100 % with condensation	
Weight	33 kg	

Wiring diagram of actuators *)

*) Detail technical informations and wiring diagrams can be found in producer's datasheet or on the website www.zpa-pecky.cz.

Elektric equipment

System DMS2 ED

The more simple system DMS2 ED substitutes electromechanical parts and/or provides for controlling the electric actuator by input analog signal as in the version Control.

Basic equipment	
Control unit	It also contains the sensor of position of the output shaft, 4 push-buttons and 3 signal LEDs for setting and checking the actuator.
Torque-limit unit	
Source unit	Contacts of seven relays (MO, MZ, PO, PZ, SO, SZ, READY) are connected to the terminal board; state of each relay is signalized by LED. The unit enables the heating resistor to be connected and controlled by the thermostat.
Optional equipment	
Feedback signal	4-20 mA
Analog regulator	
Position Indicator	LED display
Relay control or contactless control unit	
Electronic brake	

System DMS2

The system DMS2 enables the electric actuator to be used for two-position and three-position regulation or to be connected to the industrial bus bar Profibus.

Basic equipment	
Control unit	It also includes a sensor of the output shaft position 2 signal LED
Torque-limit unit	
Source unit	- 2 relays for electric motor control - Relay <i>Ready</i> with change-over contact connected to the terminal board - Signalling relays 1 - 4 with one pole of the switching contact connected to the terminal board Second poles of the switching contacts of relays 1 - 4 are interconnected and brought out to the terminal COM Heating resistor switched by a thermostat is connected to the unit The unit controls power switches of the electric motor (reversing relay) To the unit can be connected an electronic brake
Unit of display	Two-row display, 2 x 12 alpha-numeric characters
Unit of push-buttons	Push-buttons "Open", "Close", "Stop"; Selector switch "Local", "Remote", "Stop"
Recommended equipment	
Electronic brake	After switching-off the motor reduces running down and precises the control
Optional equipment (<i>the electric actuator must be fitted with one of these units</i>)	
Unit of two- and three-position control	Control of the electric actuator by shifting to position Open and Close or by analog signal 0(4) - 20 mA
Unit of connection Profibus	Control of the electric actuator by industrial bus bar Profibus

Note: The electronic control DMS2 checks, within its function, sequence and fall-out of phases of supply voltage.

Specification of actuators Modact MTNED a MTPED

Basic technical parameters

Type	Power switch setting range kN	Direct power kN	Resetting speed mm.min ⁻¹	Travel mm	Power W	Electric motor MTN			Electric motor MTP			Weight Aluminium [kg]	Specification No.	
						rpm 1/min	In (400V) A	Iz In	rpm 1/min	In (400V) A	Iz In		Basic	Additional
MTNED 15 MTPED 15	11,5 - 15	17	50	10 - 100	180	850	0.74	2.3	835	0.62	2.3	33	52 442	XX0XXED
			80		180	850	0.74	2.3	835	0.62	2.3			XX1XXED
			125		250	1350	0.77	3.0	1350	0.76	3.0			XX3XXED
			36		120	645	0.51	2.2	645	0.51	2.2			XX2XXED
			27		120	645	0.51	2.2	645	0.51	2.2			XXAXXED
MTNED 25 MTPED 25	15 - 25	32,5	50	10 - 100	180	835	0.74	2.3	835	0.62	2.3	33		XX4XXED
			80		180	835	0.74	2.3	835	0.62	2.3			XX5XXED
			125		250	1350	0.77	3.0	1350	0.76	3.0			XX6XXED
			36		120	645	0.51	2.2	645	0.51	2.2			XX7XXED
			27		120	645	0.51	2.2	645	0.51	2.2			XX8XXED
Execution Modact MTNED ... enclosure IP55													XXXXNED	
Execution Modact MTPED ... enclosure IP67													XXXXPED	

Execution, circuitry, electronic equipment

	Terminal board	Conector	Terminal board, brake	Conector, brake
DMS2, ED electronics	EXXXXED	FXXXXED	HXXXXED	KXXXXED
DMS2, Profibus electronics	PXX0XED	TXX0XED	UXX0XED	YXX0XED
DMS2, 2-position or 3-position control *)	RXX0XED	VXX0XED	WXX0XED	XXX0XED

*) Producer will set in production 2- or 3- position control. If not specified in the order, the gearmotor is set to 3-position control (signal control 4-20 mA).

Equipment of DMS2ED electronics

Equipment	Character at the 9. position (52 442 xxxXxED)																							
	0	1	2	3	4	5	6	7	8	9	A	B	C	D	E	F	H	J	K	L	M	N	P	R
Local control		x		x		x		x		x		x		x		x		x		x		x		x
Display			x	x			x	x			x	x			x	x			x				x	x
Relay					x	x	x	x					x	x	x	x					x	x	x	x
Analog module	Transmitter								x	x	x	x	x	x	x	x	x	x	x	x	x	x	x	x
	Regulator																x	x			x	x	x	x

Note: In the case of using an electronic DMS2 is the character at the 9. position 0

Connection dimensions - details of additional specification No. 52 442

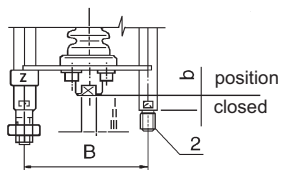

Pitch of columns	B	150
Position "closed"	b	74
	g	130
	I	M 20x1,5
Clutch thread	II	M 16x1,5
	III	M 10x1

Execution	Specification No.		For valves
	basic	additional	
Bb2I	52 442	XLXXXM	---
Bb2II	52 442	XMXXXM	RV 2xx DN 80 to 150
Bb2III	52 442	XPXXXM	RV 2xx DN 15 to 65
Bg2I	52 442	XRXXXM	RV 2xx DN 200 to 400

Dimensions of actuator Modact MTNED/MPED

- with conector

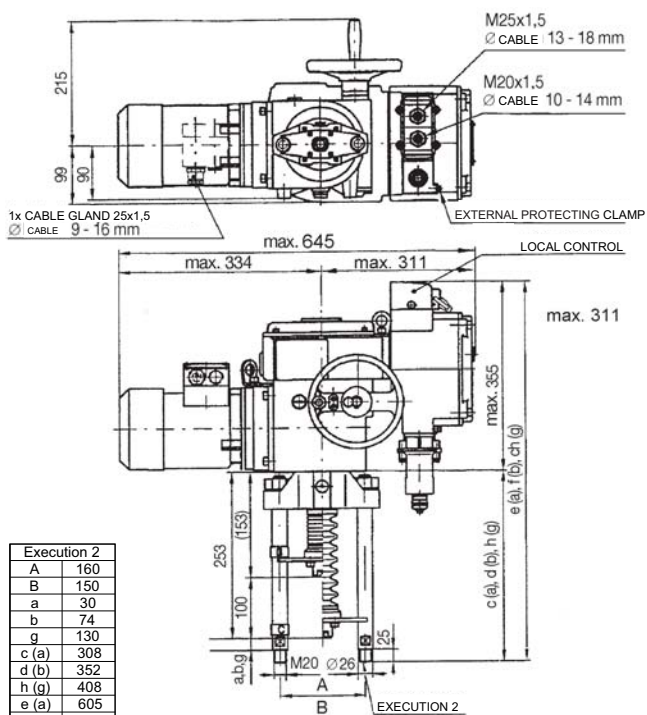

Execution 2	
A	160
B	150
a	30
b	74
g	130
c (a)	308
d (b)	352
h (g)	408
e (a)	605
f (b)	649
ch (g)	705

- with terminal board

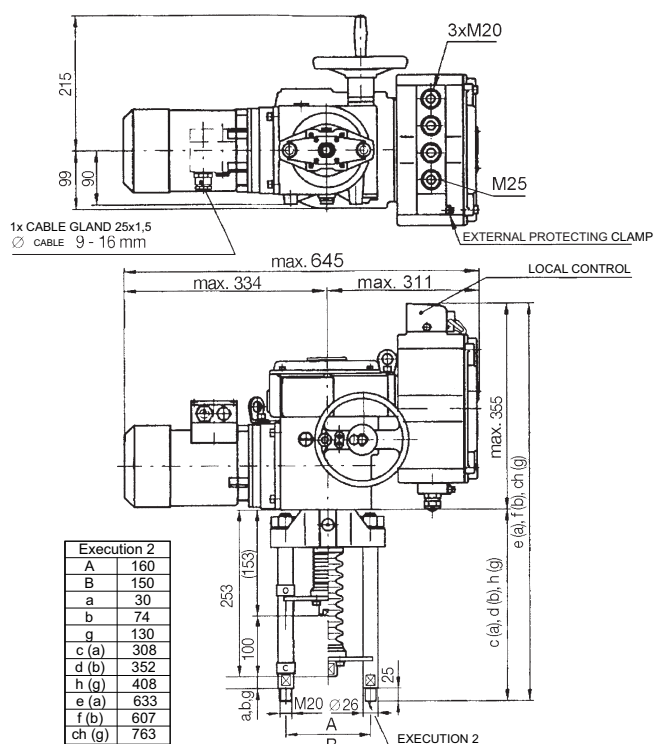

Execution 2	
A	160
B	150
a	30
b	74
g	130
c (a)	308
d (b)	352
h (g)	408
e (a)	633
f (b)	607
ch (g)	763

Detail of coupling

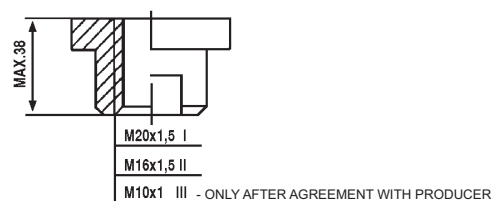



EAA, EAB, EAC, EAD EAE, EAF, EAG, EAH

Electric actuators
SA 07.1, SA ExC 07.1, SAR 07.1, SAR ExC 07.1
SA 07.5, SA ExC 07.5, SAR 07.5, SAR ExC 07.5
Auma

Technical data

Type	SA 07.1	SA ExC 07.1	SAR 07.1	SAR ExC 07.1	SA 07.5	SA ExC 07.5	SAR 07.5	SAR ExC 07.5
Marking in valve specification No.	EAA	EAB	EAC	EAD	EAE	EAF	EAG	EAH
Voltage	380 or 400 V AC							
Frequency	50 Hz							
Motor power	See specification table							
Control	3 - position control or with signal 4 - 20 mA							
Nominal force	10 Nm ~ 5 kN; 15 Nm ~ 7,5 kN; 20 Nm ~ 10 kN				30 Nm ~ 15 kN; 40 Nm ~ 20 kN			
Travel	acc to valve stroke 16, 25, 40 mm				acc to valve stroke 80, 100 mm			
Enclosure	IP 67							
Process medium max. temperat.	Acc. to used valve							
Ambient temperature range	-25 to 80°C	-20 to 40°C	-25 to 60°C	-20 to 40°C	-25 to 80°C	-20 to 40°C	-25 to 60°C	-20 to 40°C
Ambient humidity limit	100 %							
Weight	20 kg							

Specification of Auma actuators

Type	SA	X	XXX	07.X
Duty	SA	R		
Execution	Standard		ExC	
Actuator' s size				07.1 07.5

Output shaft type A (thread TR 16x4 LH, connection flange F07) ... for RV 2xx DN 15 to 150

Output speed (rpm)	Tripping torque	SA 07.1	SAR 07.1	SA 07.1	SA ExC 07.1	SAR 07.1	SAR ExC 07.1
		SAExC 07.1	SARExC 07.1				
4	10-30 Nm 15-30 Nm			0,025	0,025	0,025	0,025
5,6				0,025	0,025	0,025	0,025
8				0,045	0,045	0,045	0,045
11				0,045	0,045	0,045	0,045
16				0,09	0,09	0,09	0,09
22				0,09	0,09	0,09	0,09
32				0,18	0,18	0,18	0,18
45				0,18	0,18	0,18	0,18

Output shaft type A (thread TR 20x4 LH, connection flange F10) ... for RV 2xx DN 80 to 400

Output speed (rpm)	Tripping torque	SA 07.5	SAR 07.5	SA 07.5	SA ExC 07.5	SAR 07.5	SAR ExC 07.5
		SAExC 07.5	SARExC 07.5				
4	20-60 Nm 30-60 Nm			0,045	0,045	0,045	0,045
5,6				0,045	0,045	0,045	0,045
8				0,09	0,09	0,09	0,09
11				0,09	0,09	0,09	0,09
16				0,18	0,18	0,18	0,18
22				0,18	0,18	0,18	0,18
32				0,37	0,37	0,37	0,37
45				0,37	0,37	0,37	0,37

Accessories

2 TANDEM switches

Gearing for signalisation of position

Mechanical position indicator

Potentiometer 1x200 Ω

Electronic position transmitter RWG (potentiometer included), 4 - 20 mA, 2-wire

Electronic position transmitter RWG (potentiometer included), 4 - 20 mA, 3/4-wire

Inductive position transmitter IWG, 4 - 20 mA

MATIC - or continuous control (specification of accessories acc. to catalogue of producer), weight + 7 kg

AUMATIC - or continuous control (specification of accessories acc. to catalogue of producer), weight + 7kg

Other accessories acc. to catalogue of producer of actuators.

Dimension of Auma actuators 07.1 and 07.5

Standard execution

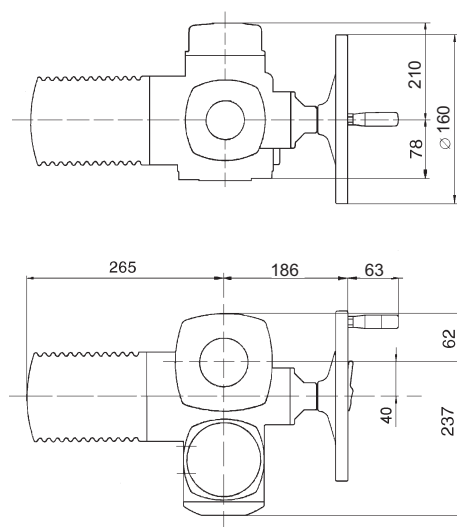

ExC execution

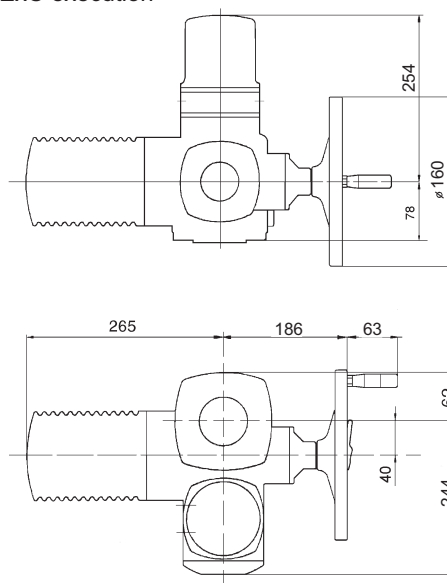

Version with MATIC / AUMATIC

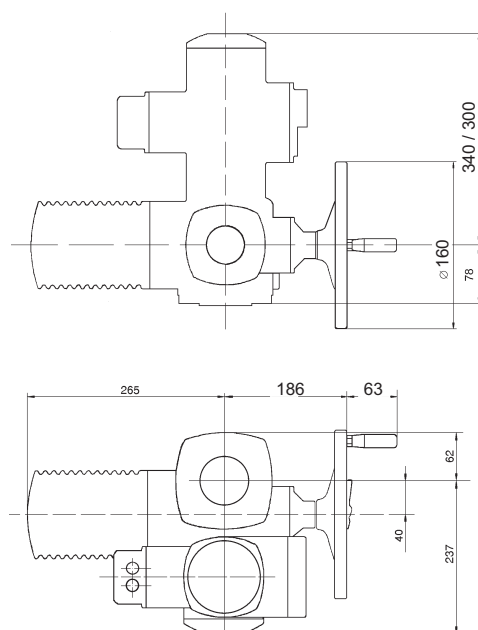

Output drive type A

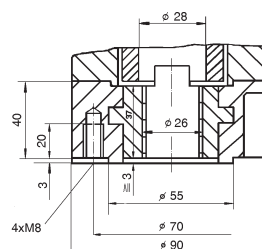

Attachment yoke (2 or 4 columns)

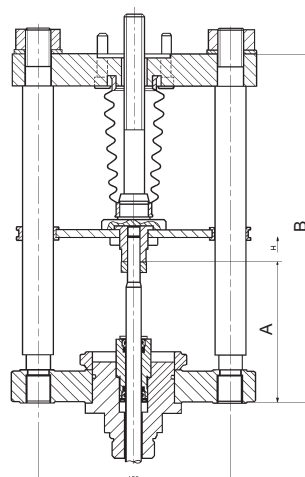

For valves	Number of columns	A	B	Weight
RV 2xx DN 15 to 150	2	110	272	~ 8 kg
RV 2xx DN 200 to 400	4	140	420	~ 15 kg

EAI, EAJ EAK, EAL



Electric actuators SA 10.1, SA ExC 10.1 SAR 10.1, SAR ExC 10.1 Auma

Technical data

Type	SA 10.1	SA ExC 10.1	SAR 10.1	SAR ExC 10.1
Marking in valve specification No.	EAI	EAL	EAJ	EAK
Voltage	380 or 400 V			
Frequency	50 Hz			
Motor power	See specification table			
Control	3 - position control or with signal 4 - 20 mA			
Nominal force	80 Nm ~ 21,6 kN; 100 Nm ~ 27 kN; 120 Nm ~ 32 kN			
Travel	Acc. to used valve 80, 100 mm			
Enclosure	IP 67			
Process medium max. temperatur.	Acc. to used valve			
Ambient temperature range	-25 to 80°C	-20 to 40°C	-25 to 60°C	-20 to 40°C
Ambient humidity limit	100 %			
Weight	24 to 27 kg			

Specification of Auma actuators

Type	SA	X	XXX	10.1
Duty	SA	R		
Execution	Standard			
Actuator's size	Non-explosive		ExC	10.1

Output shaft type A (thread TR 36x4 LH, connection flange F10) ... for RV 2x4 DN 200 to 600

Output speed (rpm)	Tripping torque	SA 10.1	SAR 10.1	SA 10.1	SA ExC 10.1	SAR 10.1	SAR ExC 10.1
		SAExC 10.1	SARExC 10.1				
4	40-120 Nm 60-120 Nm			0,09	0,09	0,09	0,09
5,6				0,09	0,09	0,09	0,09
8				0,18	0,18	0,18	0,18
11				0,18	0,18	0,18	0,18
16				0,37	0,37	0,37	0,37
22				0,37	0,37	0,37	0,37
32				0,75	0,75	0,75	0,75
45				0,75	0,75	0,75	0,75

Accessories

2 TANDEM switches

Gearing for signalisation of position

Mechanical position indicator

Potentiometer 1x200 Ω

Electronic position transmitter RWG (potentiometer included), 4 - 20 mA, 2-wire

Electronic position transmitter RWG (potentiometer included), 4 - 20 mA, 3/4-wire

Inductive position transmitter IWG, 4 - 20 mA

AUMATIC - for continuous control (specification of accessories acc. to catalogue of producer)

Other accessories acc. to catalogue of producer of actuators.

Dimension of Auma actuators 10.1

Standard execution

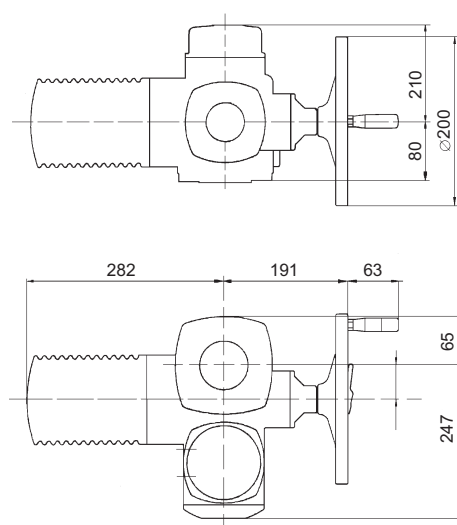

ExC execution

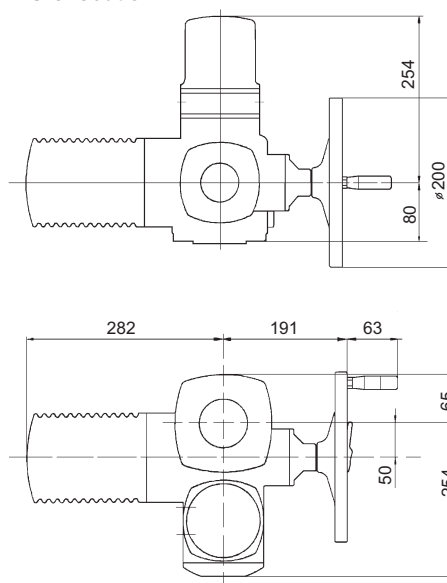

Version with MATIC / AUMATIC

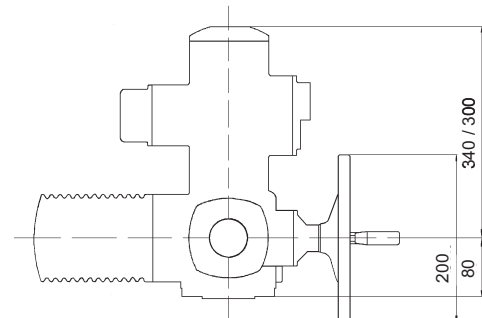

Output drive type A, F 10

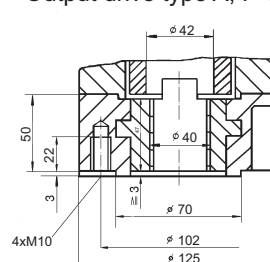

Attachment yoke DN 200 - 400 Attachment yoke DN 600
Output drive type A, F10, Tr36x6-LH Output drive type A, F10, Tr36x6-LH

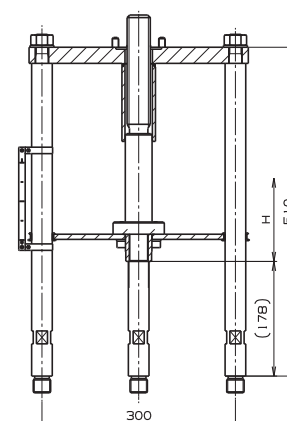
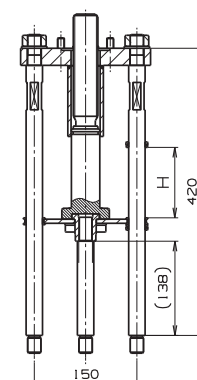
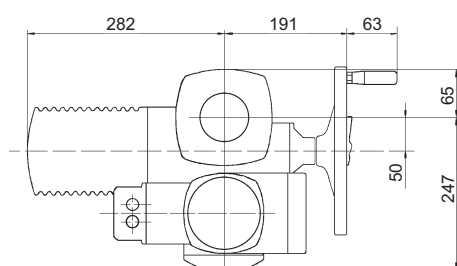



**EZA, EZB
EZE, EZF
EZE, EZF
EZG, EZH**

Electric actuators ...AB3, ...AB5 Schiebel

Technical data

Type	AB3	AB5	exAB3	exAB5	rAB3	rAB5	exrAB3	exrAB5
Mark in valve's spec. No.	EZA	EZE	EZB	EZF	EZC	EZG	EZD	EZH
Voltage AC	400 / 230 V; 230 V		400 / 230 V		400 / 230 V; 230 V		400 / 230 V	
Frequency	50 Hz							
Motor power	See specification table							
Control	3 - position control of continuous 4 - 20 mA							
Nominal force	80 Nm ~ 32 kN							
Stroke	Acc. to the valve stroke 16, 25, 40, 80, 100 mm							
Enclosure	IP 66		IP 65		IP 66		IP 65	
Process medium max. t.	Acc. to used valve							
Ambient temp. range	-25 to 80°C		-20 to 40°C		-25 to 80°C		-20 to 40°C	
Ambient humidity limit	90 % (tropical version: 100 % with condensation)							
Weight	16 kg		12 kg		16 - 18 kg		16 kg	

Specification of actuators

						XX	X	AB3	A	X	+	XXX	
Execution		Non-explosive				Ex							
		Standard											
Duty		Control					R						
		ON - OFF											
Actuator's torque								AB3					
								AB5					
Output shaft type A (thread TR 16x4 LH, connection flange F07 ... for RV 2x4 DN 200 to 400)									A				
Output speed (rpm)	Tripping torque	AB3	rAB3	AB3		rAB3		exAB3	exrAB3				
		exAB3	exrAB3	400/230V	230V	400/230V	230V	400/230V	400/230V				
		10-30 Nm	Tripping 7 - 30 Nm	Motor power [kW]	0,09	0,09	0,09	0,09	0,09	0,09			2,5
					0,03	0,12	0,03	0,12	0,12	0,12			5
					0,09	0,09	0,09	0,09	0,09	0,09			7,5
					0,09	0,09	0,09	0,09	0,09	0,09			10
					0,09	0,09	0,09	0,18	0,09	0,09			15
					0,09	0,18	0,09	0,37	0,09	0,09			20
0,55	0,25				0,25	0,25	0,37	0,18			30		
0,55	0,25	0,25	0,25	0,37	0,18			40					
Output speed (rpm)	Tripping torque	AB5	rAB5	AB5		rAB5		exAB5	exrAB5				
		exAB5	exrAB5	400/230V	230V	400/230V	230V	400/230V	400/230V				
		10-60 Nm	Tripping 30 - 60 Nm	Motor power [kW]	0,09	0,09	0,09	0,09	0,09	0,09			2,5
					0,12	0,12	0,12	0,12	0,12	0,12			5
					0,09	0,12	0,09	0,09	0,09	0,09			7,5
					0,12	0,25	0,12	0,12	0,18	0,18			10
					0,18	0,25	0,18	0,18	0,18	0,18			15
					0,18	0,55	0,18	0,18	0,37	0,37			20
0,37	0,75				0,37	0,37	0,37	0,37			30		
0,37	1,10	0,37	0,37	0,37	0,37			40					
Accessories		Potentiometer 1x1000 Ω										F	
		Double potentiometer											FF
		Electronic transmitter 4 - 20 mA											ESM21
		Positioner ACTUMATIC R											CMR
		SMARTCON control unit											CSC

Dimension of actuators ...AB3, ...AB5

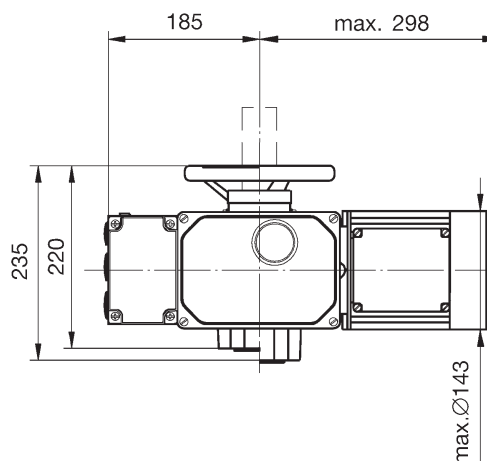
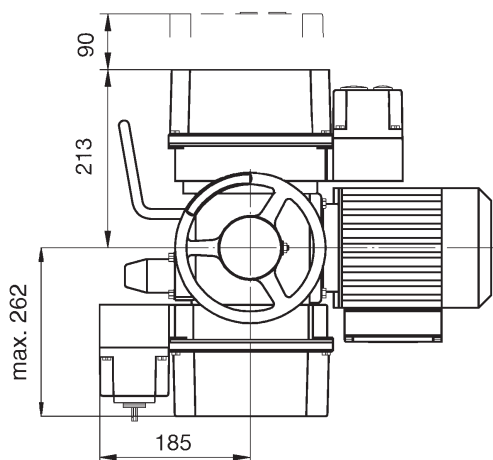

Output drive type A

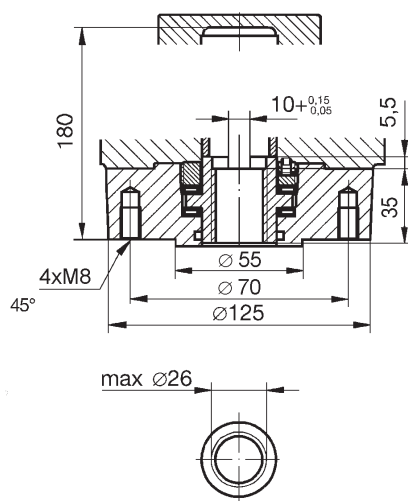

Attachment yoke

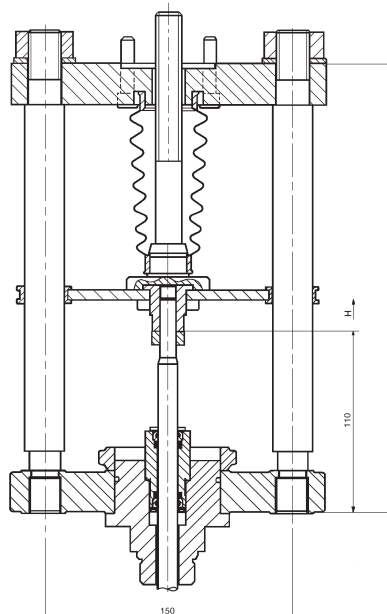

For valves	Number of columns	A	B	Weight
RV 2xx DN 15 až 150	2	110	272	~ 8 kg
RV 2xx DN 200 až 400	4	140	420	~ 15 kg



**EZK
EZL**

Electric actuators ...AB8 Schiebel

Technical data

Type	rAB8	exrAB8
Marking in valve's specification No.	EZK	EZL
Voltage AC	400 / 230 V; 230 V	400 / 230 V; 230 V
Frequency	50 Hz	
Motor power	See specification table	
Control	3 - position or with signal of 4 - 20 mA	
Nominal force	(Tr 20x4 LH) 30 Nm ~ 15 kN; 40 Nm ~ 20 kN (Tr 36x6 LH) 80 Nm ~ 21,6 kN; 100 Nm ~ 27 kN; 120 Nm ~ 32 kN	
Stroke	IP 66	25 mm
Enclosure		IP 65
Process medium max. temp.	-25 to 80°C	Acc. to used valve
Ambient temperature range		-20 to 40°C
Ambient temperature limit	90 % (tropical version 100 % with condensation)	
Weight	24 kg	20 kg

Specification of actuator

Execution		Non-explosive	XX	X	AB8	A	X	+	XXX	
Duty		Normal	ex							
Actuator size		Control		r	AB8					
Output shaft type (connection flange size F10, thread 20x4... for RV 2xx DN 250 to 600)						A				
Output speed [rpm]	Tripping torque	rAB8 30-80 Nm	Motor power [kW]	rAB8		exrAB8				
				400/230V	230V	400/230V				
				2,5	0,12	0,12	0,12			2,5
				5	0,12	0,12	0,12			5
				7,5	0,18	0,18	0,18			7,5
				10	0,37	0,37	0,18			10
				15	0,37	0,37	0,37			15
				20	0,55	0,75	0,37			20
				30	0,75	1,10	0,75			30
40	1,10	1,10	1,10			40				
Accessories		Potentiometer 1x1000 Ω							F	
		Double potentiometer							FF	
		Electronic transmitter 4 - 20 mA								ESM21
		Positioner ACTUMATIC R								CMR
		SMARTCON control unit								CSC

*) for switching torques exceeding 40 Nm the thread TR 36x6 LH, flange F10 is applied

Dimensions of actuators ...AB8

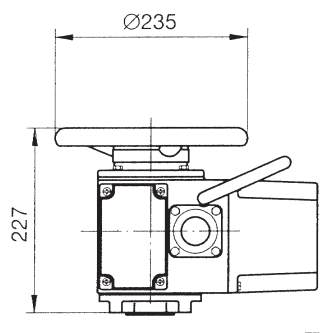
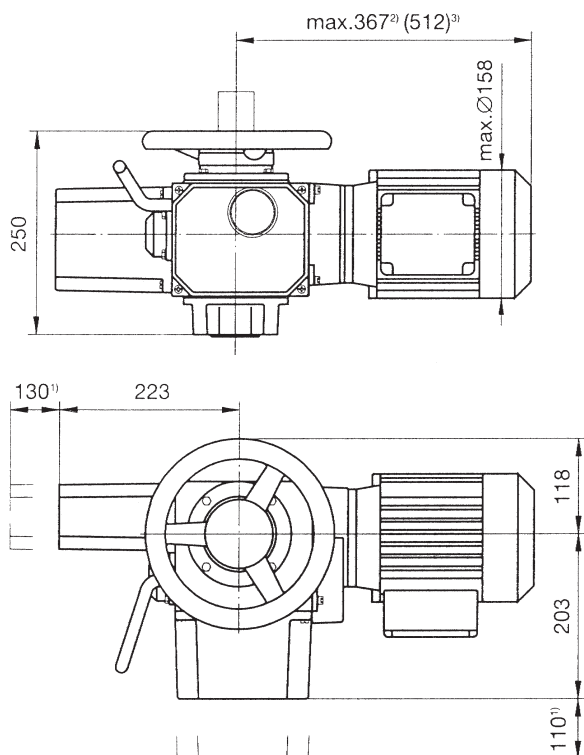

Output shaft type A, flange F10

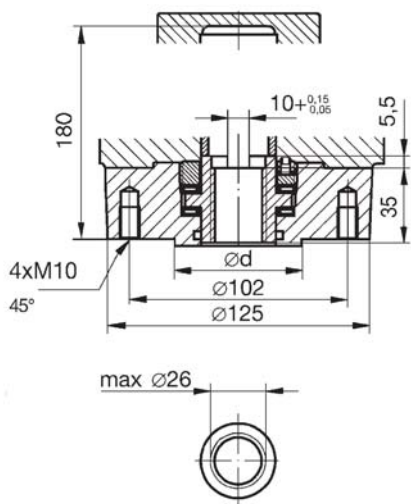

Attachment yoke DN 200 - 400 Attachment yoke DN 600
Output drive type A, F10, Tr36x6-LH Output drive type A, F10, Tr36x6-LH

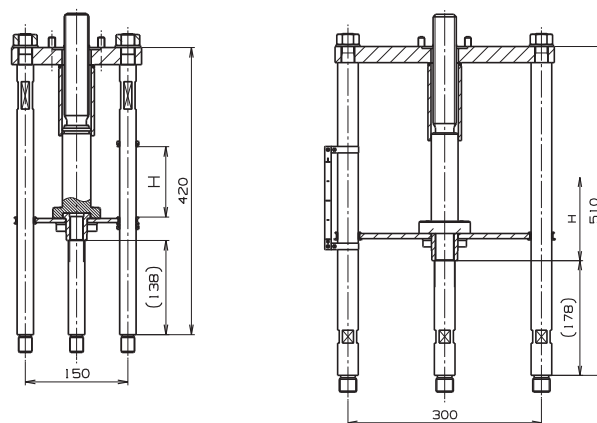



EDA, EDB, EDC EDD, EDI, EDK

Electric actuators D, DR, DMI, DMI R EMG - Drehmo

Technical data

Type	D30	DMI30	DR30	DMIR30	DR30Ex	DMIR30Ex
Mark in valve's spec. No.	EDA	EDC	EDB	EDD	EDI	EDK
Voltage	380 / 400 V; 230 V AC					
Frequency	50 Hz					
Motor power	See specification table					
Control	3 - position control or continuous 4 - 20 mA					
Nominal force	15 Nm ~ 7,5 kN; 20 Nm ~ 10 kN; 30 Nm ~ 15 kN					
Stroke	Acc. to the valve stroke: 16, 25, 40, 63 mm					
Enclosure	IP 67					
Process medium max.t.	Acc. to used valve					
Ambient temp. range	-25 to 80°C	-25 to 70°C	-25 to 40°C			
Ambient humidity limit	100 % with condensation					
Weight	18 kg	28 kg	18 kg	28 kg	18 kg	28 kg

Specification of actuators EMG - Drehmo

Type	Drehmo Standard		XXX	X	XX	A	XXX	XX
	Drehmo Matic		D					
Duty	Control		DMI					
	ON - OFF			R				
Actuator's torque	30 [Nm]				30			
Output shaft type A (thread TR 16x4 LH, connection flange F07; thread TR 20x4 LH, flange F10)								
Output speed (rpm)	Tripping torque	D30... DMI30... DR30... DMIR30...	Motor power [kW]	D 30	DMI R 30			
		DR 30		DMIR30Ex				
		DMI 30						
		D R 30 Ex						
		0,12		0,12	5			
		0,12		0,12	10			
		0,12		0,12	16			
		0,12		0,12	25			
		0,34		0,34	32			
		0,25		0,25	40			
0,34	---	50						
0,34	---	80						
0,34	---	120						
0,75	---	160						
Execution		Normal						
		Non-explosive						Ex

Accessories

1. Torque switches in closing and opening direction DR11/DL21
2. Resistance sensor 22 Ω, B1
3. Electronic transmitter, feeding 24 V; feedback 0/4 - 20 mA
4. Mechanical position indicator
5. Position signalisation drive (necessary for item No. 2 and 4)

Dimension of actuators EMG - Drehmo

Standard execution

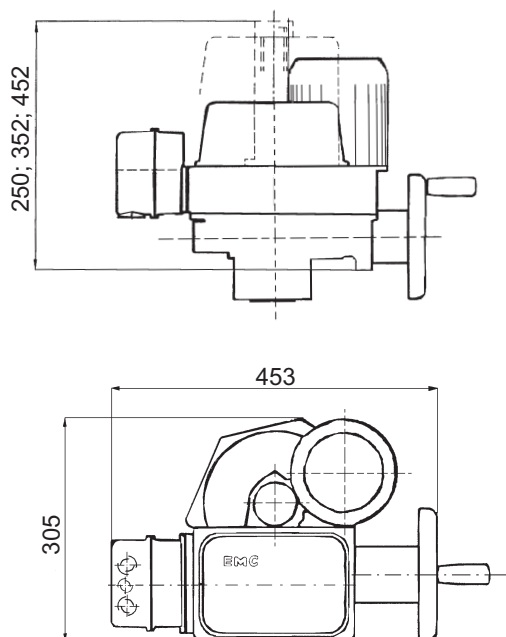

Version with MATIC

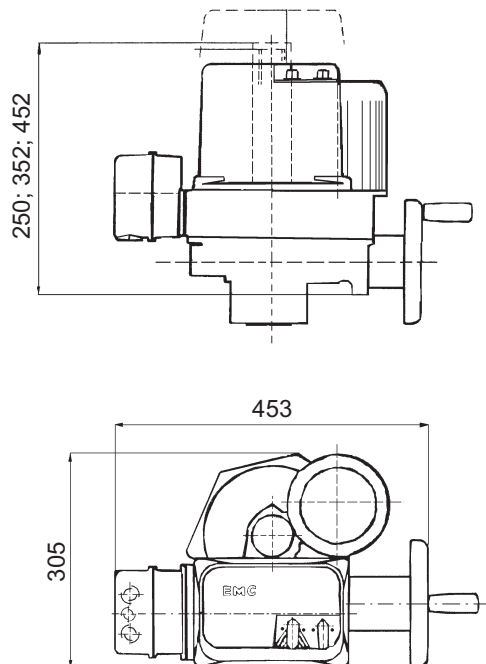

Output drive type A, flange F07

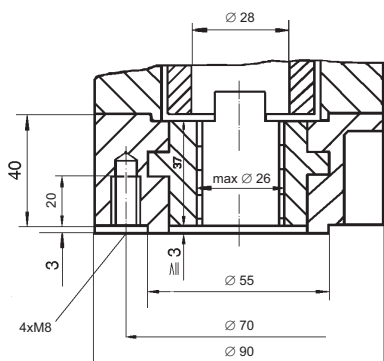

Attachment yoke

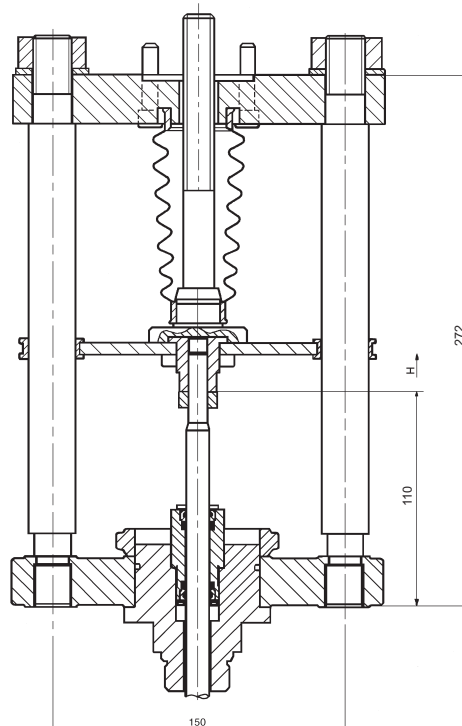

EQA, EQB



Elektric actuators ...IQM7 Rotork

Technical data

Type	IQM7	Ex IQM7
Marking in valve specification No.	EQA	EQB
Voltage	400 V AC	
Frequency	50 Hz	
Motor power	See specification table	
Control	0 - 5, 0 - 10, 0 - 20 and 4 - 20 mA; 0 - 5, 0 - 10 and 0 - 20 V	
Torque	15 Nm ~ 7,5 kN; 20 Nm ~ 10 kN; 30 Nm ~ 15 kN	
Stroke	Acc. to valve stroke 16, 25, 40 mm	
Enclosure	IP 68	
Process medium max. temperature	Acc. to used valve	
Ambient temperature range	-20 to 70 °C	
Weight	30 kg	

Specification of actuator

		XX	IQM7	A	X	+	XXX
Execution	Non-explosive		Ex				
	Standard						
Actuator's size			IQM7				
Output drive type (thread TR 20x4 LH, connection flange F10)				A			
Output speed (rpm)	18	Tripping torque	IQM7				
			13,6-34 Nm				
		Motor power [kW]	IQM7	Ex IQM7			
			0,05	0,05		18	
Accessories		Positioner Folomatic					Folomatic
		Position transmitter 4 - 20 mA					CPT
		Output torque transmitter 4 - 20 mA					CTT

Dimensions of actuators ... IQM7

Actuator ... IQM7

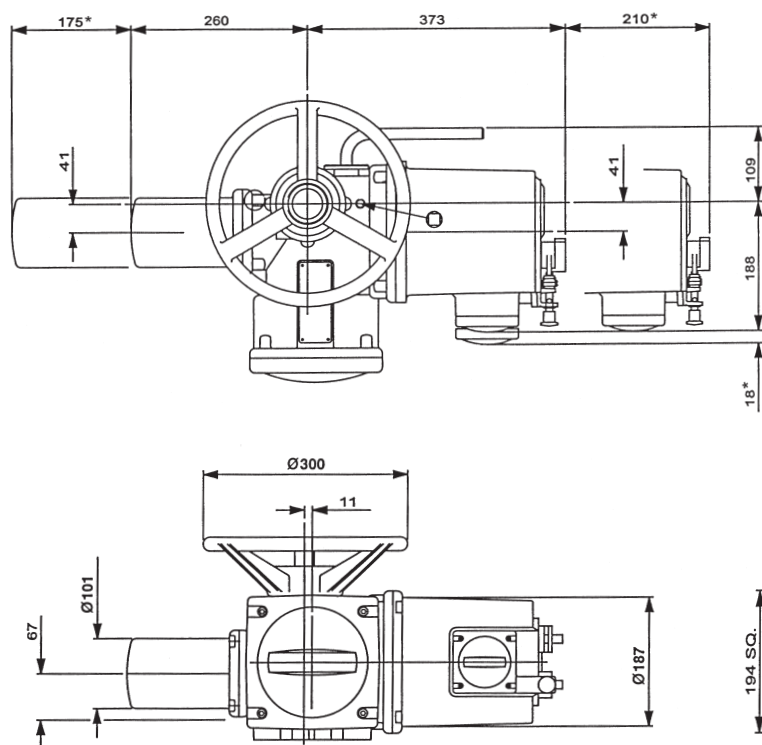

Output drive type A

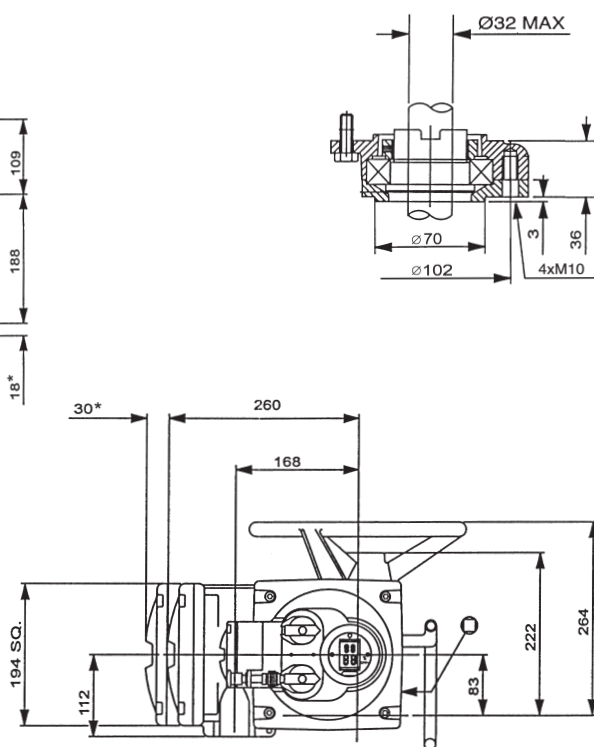

Dimension marked * - free place for dismantling of actuator's housing

Attachment yoke

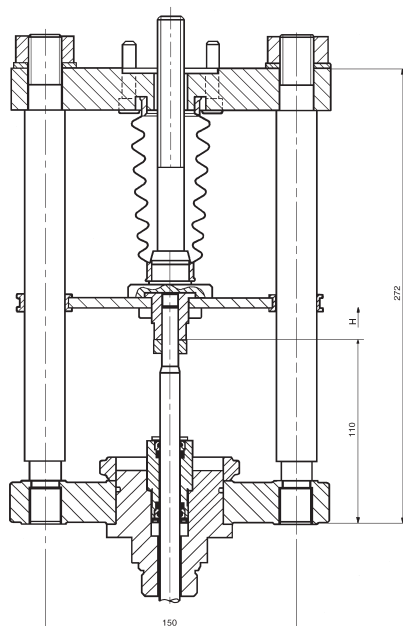



Electric actuator Modact MTR Regada

Technical data

Type	Modact MTR
Marking in valve specification No.	EPD
Voltage	230 V AC
Frequency	50 / 60 Hz
Motor power	16 or 25 W
Control	3 - pos. c. (in connection with NOTREP positioner - continuous)
Nominal force	6.3, 10, 16, 25 kN
Travel	12,5 to 100 mm
Enclosure	IP 54 (IP 65 on request)
Process medium max. temperature	Acc. to used valve
Ambient temperature range	-25 to 50°C
Ambient humidity limit	90 %
Weight	27 to 31 kg

Dimensions of Modact MTR

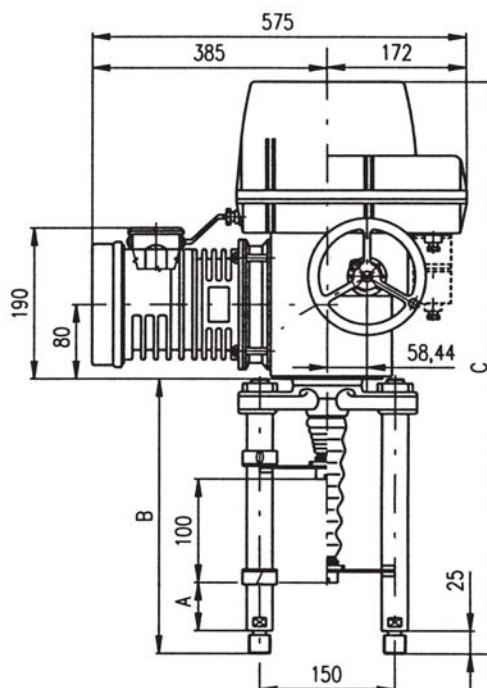
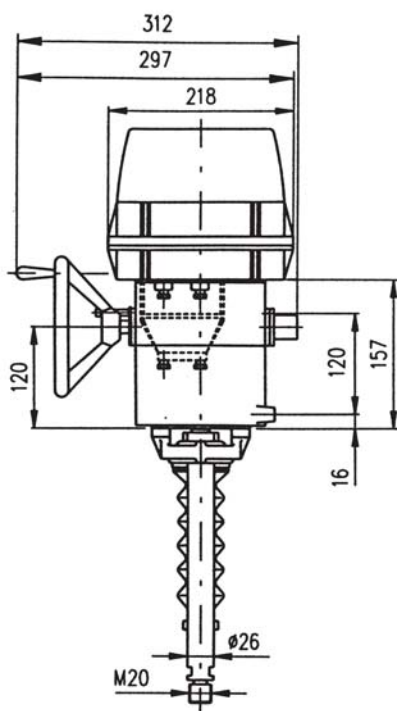

Detail of coupling

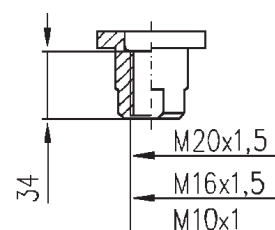

columns	with acme thread			columns	with ball bolt			for valves
	version	A	B		C	version	A	
P-1045a/B	74	320	649	P-1045a/E	74	344	673	RV 2xx DN 15 to 150
P-1045a/C	130	378	707	P-1045a/H	130	400	729	RV 2xx DN 200 to 400

Specification of Modact MTR

Electric actuator MTR, linear					52 420.	X	-	X	X	X	X	X	/	X	X				
Mild up to hot dry with temperature range (-25 °C to +50 °C)					0														
Electric connection		Voltage			Wiring diagram														
To terminal board		230 V AC			Z296														
To connector									9										
Screw version		Switching-off thrust ^{1) 2)}	Rated operating speed	Operating speed	Electric motor														
					Power	Speed	Current												
trapezoidal thread	6 300/32	4.0 - 6.3 kN	32 mm/min.	38 - 32 mm/min.	16 W	1 150	0.31 A							A					
	4 000/50	2.4 - 4.0 kN	50 mm/min.	60 - 50 mm/min.													B		
	10 000/32	6.3 - 10.0 kN	32 mm/min.	38 - 32 mm/min.	25 W	1 250	0.41 A							C					
	6 300/50	4.0 - 6.3 kN	50 mm/min.	60 - 50 mm/min.													D		
ball screw	16 000/32-G	10.0 - 16.0 kN	32 mm/min.	38 - 32 mm/min.	16 W	1 150	0.31 A							E					
	10 000/50-G	6.3 - 10.0 kN	50 mm/min.	60 - 50 mm/min.													F		
	25 000/32-G	10.0 - 25.0 kN	32 mm/min.	38 - 32 mm/min.	25 W	1 250	0.41 A							G					
	16 000/50-G	10.0 - 16.0 kN	50 mm/min.	60 - 50 mm/min.													H		
	10 000/63-G	6.3 - 10.0 kN	63 mm/min.	75 - 63 mm/min.													J		
	6 300/100-G	4.0 - 6.3 kN	100 mm/min.	120 - 100 mm/min.														K	
Control board version		Operating stroke			Wiring diagram														
Electromechanical control board - without local control		16 mm			Z298									B					
		25 mm															C		
		40 mm																E	
		63 mm																F	
		80 mm																G	
		100 mm																H	
Transmitter		Connection		Output		Wiring diagram													
Without transmitter		—		—		—								A					
Resistive	Single		—		1x100 Ω		Z5a							B					
	Double				2x100 Ω		Z6a								C				
	Single				1x2000 Ω		Z5a								F				
	Double				2x2000 Ω		Z6a								P				
Resistive with current converter	Without power supply		2-wire		4 - 20 mA		Z10a							S					
	With power supply				Z269a										Q				
	Without power supply		3-wire		0 - 20 mA		Z257a							T					
	With power supply				Z260a										U				
	Without power supply				4 - 20 mA		Z257a									V			
	With power supply				Z260a											W			
	Without power supply		3-wire		0 - 5 mA		Z257a								Y				
	With power supply				Z260a											Z			
Capacitive CPT	Without power supply		2-wire		4 - 20 mA		Z10a							I					
	With power supply				Z269a										J				
Mechanical connection	Connecting height / stroke		Pillar spacing / Bore of flange		Thread of stem ³⁾		Dimensional drawing												
Columns	74/100		150/ —		M20x1.5		P-1045a/B; P-1045a/E							B					
	130/100				M16x1.5, M10x1		P-1045a/C; P-1045a/H									C			
Additional equipment					Wiring diagram														
	Without additional equipment; adjusted max. switching-off thrust from range														0 1				
A	2 additional position switches S5,S6					Z298									0 2				
B	Adjustment of switching-off thrust for required value														0 3				

Possible combinations and execution: A+B = 07

Notes:

- 1) State the switching-off thrust in your order by words. If not stated it is adjusted to the maximum rate of the corresponding range. The load torque equals minimally the maximum switching-off thrust of the choosing range multiplied by 1.3.
- 2) The maximum load thrust equals the max. Switching-off thrust multiplied by:
 - 0.8 for duty cycle S2-10 min., or S4-25%, 6 - 90 cycles per hour
 - 0.6 for duty cycle S4-25%, 90 - 1200 cycles per hour
- 3) The thread in the coupling is to be specified in the order by words.

Wiring diagram of actuator Modact MTR

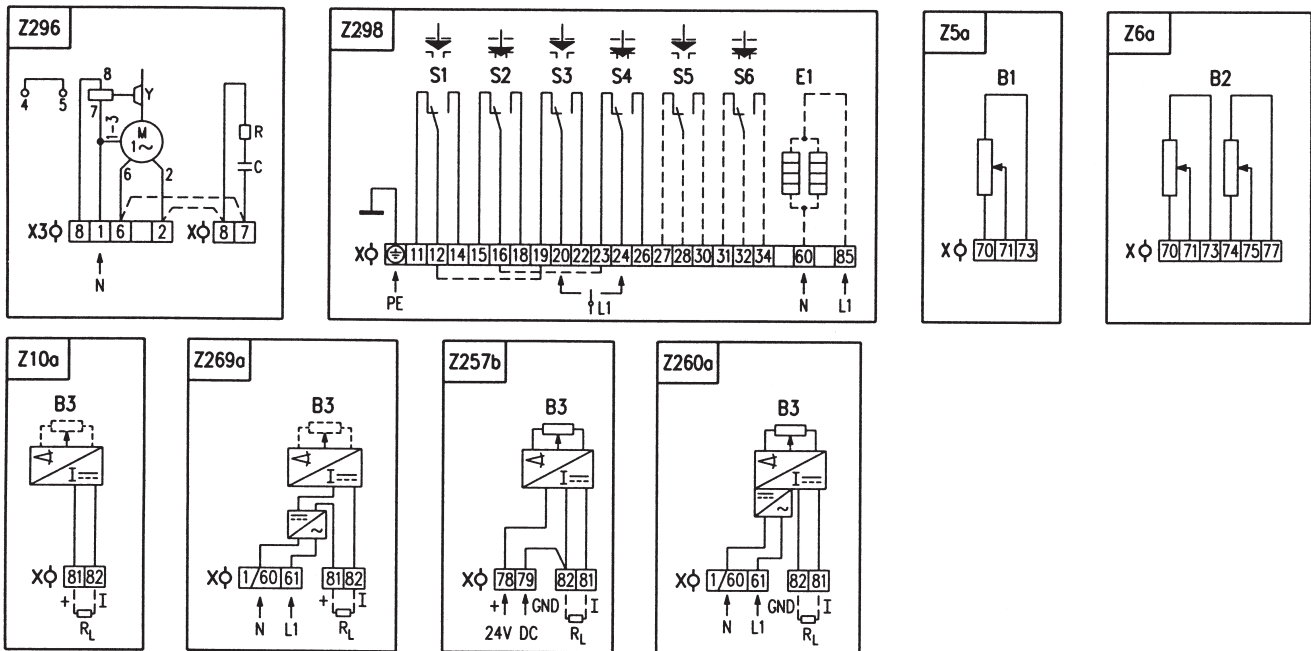

Notes:

1. For the EA version with connection to the terminal board, the terminal 1/60 (the wiring diagrams Z269a and Z260a) is leaded out to the terminal No. 1.
2. For EA version with connection to the terminal board the actuator is not equipped by the jumper X3:6-X:7 and X3:2-X:8 (Z296) from manufacturing plant (it is necessary to connect it by customer).

Legend:

- Z5a connection of single resistive transmitter
 Z6a connection of double resistive transmitter
 Z10a connection of resistive with current converter of capacitive transmitter - 2-wire without supply
 Z257b connection of resistive transmitter with current converter - 3-wire
 Z260a connection of resistive transmitter with current converter - 3-wire with power supply
 Z269a connection of resistive transmitter with current converter or capacitive transmitter - 3-wire with power supply
 Z296 connection of 1-phase electric motor
 Z298 connection of thrust and position switches and space heater

- B1 resistive transmitter (potentiometer) single
 B2 resistive transmitter (potentiometer) double
 B3 capacitive transmitter
 S1 thrust switch "open"
 S2 thrust switch "closing"
 S3 position switch "open"
 S4 position switch "closed"
 S5 additional position switch "open"
 S6 additional position "closed"
 M motor
 C capacitor
 Y motor's brake
 E1 space heater
 X terminal board
 X3 electric motor's terminal board
 I/U input (output) current (voltage) signals
 R reducing resistor
 R_L loading resistor



Electric actuators ST 0 Regada

Technical data

Type	ST 0
Marking in valve specification No.	EPK
Voltage	230 V AC, 24 V AC
Frequency	50 / 60 Hz
Motor power	1 W
Control	3 - position (0 - 10 V, (0)4 - 20 mA)
Nominal force	2,9 kN and 4,5 kN
Travel	16, 25 mm
Enclosure	IP 54
Proces medium max. temperature	acc. to used valve
Ambient temperature range	-25 to 55° C
Ambient humidity range	5 - 100% with condensation
Weight	2,5 to 4,5 kg

Dimensions of actuators

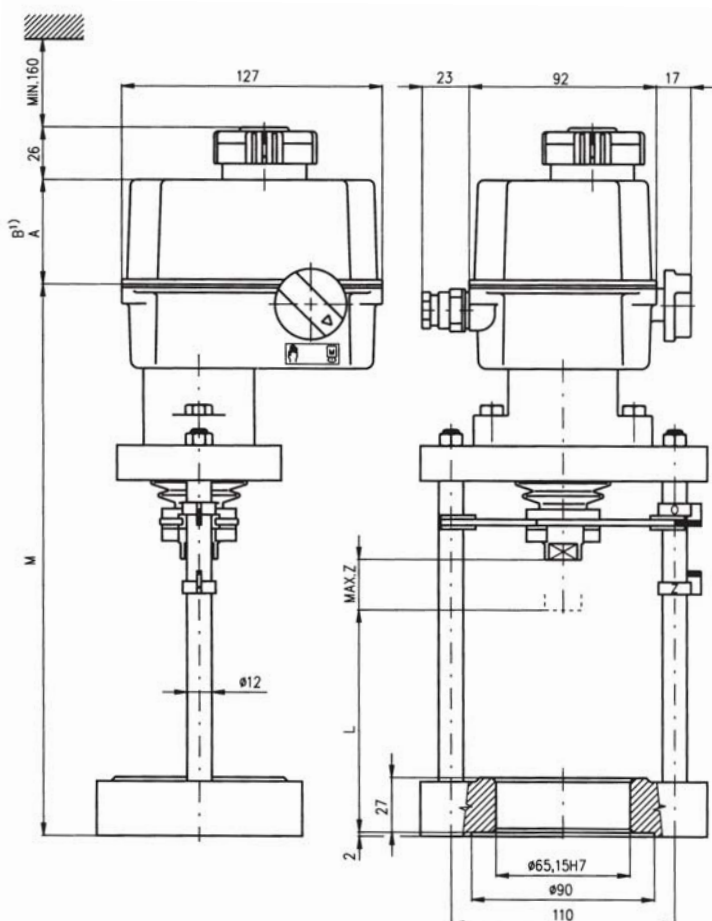

Dimensions of coupling

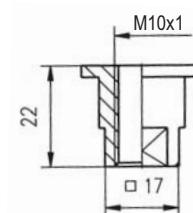

Execution	L	Z	M	A	B
P-1182/A	110	25	275	55	85

¹⁾ applies to actuators ES ST 0 with converter and to ES ST 0 with positioner

Specification of actuator ST 0

Electric actuator Isomact ST 0				490.	X	-	X	X	X	X	X	X	/	X	X		
Resistance to surroundings		Normal execution (without positioner)				0											
		S regulátorem ¹⁾		Wiring diagram		Z236, Z237											
Electric connection		Terminal board		Wiring diagram Z20		Voltage		230 V AC		0							
								24 V AC		3							
Nominal force [N]		Running speed		Motor power		4 mm/min		1 W		0							
						5 mm/min		2,75 W		A							
						10 mm/min		2,75 W		N							
						16 mm/min		2,75 W		P							
Tripping torque		One-torque		Travel		16 mm				D							
						25 mm		F									
		Two-torque				16 mm		R									
						25 mm		T									
Remote position transmitter		Without transmitter				-											
		Resistance		Single		Feedback		1 x 100 Ω		Wiring diagram		Z22					
								1 x 2000 Ω				Z23					
		Electronic - current (without generator)		2-wire		Feedback		4 - 20 mA				S					
								0 - 20 mA				T					
				3-wire				4 - 20 mA				V					
0 - 5 mA								Y									
Mechanical connection - flange, connecting height 110 mm, thread on con. stem M10x1															L		
Accessories				2 auxiliary position switches ²⁾				Z21								0 0	

Note: ¹⁾ The actuator is not equipped with hand wheel if Regada positioner is used

²⁾ The version with a positioner and with a lead-out transmitter cannot have specified also 2 additional position switches

Wiring diagram for actuator ST 0

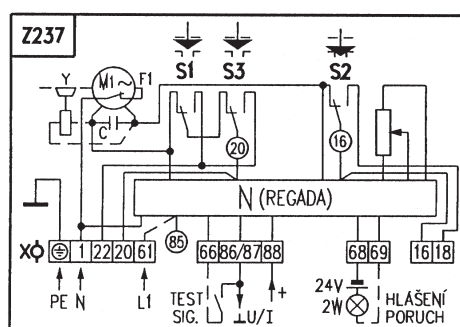
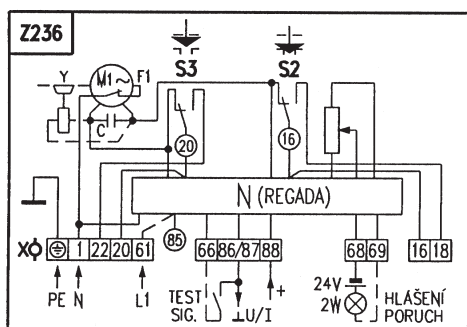
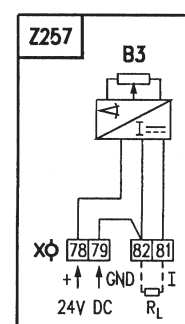
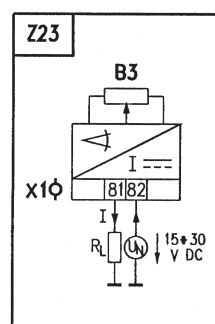
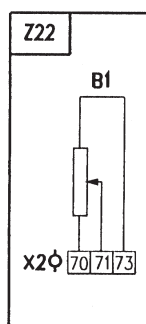
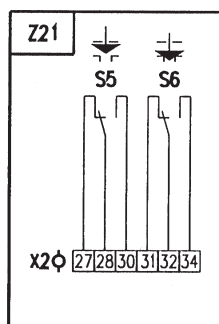
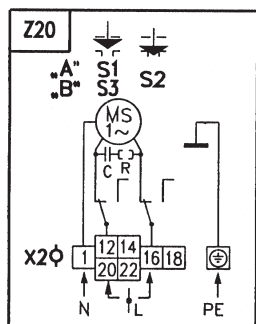

B1 remote position transmitter - resistance, single
 B3 resistance transmitter with converter
 M, MS single-phase electromotor
 C capacitor
 N positioner
 F1 heat protection of electromotor
 X, X1, X2 terminal board
 Y brake of electromotor
 R loading resistance
 RL ballast resistor

S1 power switch for "open" position
 S2 power switch for "closed" position
 S3 position switch for "open" position
 S4 position switch for "closed" position
 S5 additional limit switch for "open" position
 S6 additional limit switch for "closed" position
 I(U) input and feedback current (voltage) signals



Electric actuators ST 0.1 Regada

Technical data

Type	ST 0.1
Marking in valve specification No.	EPL
Voltage	230 V AC, 24 V AC
Frequency	50 / 60 Hz
Motor power	15W
Control	3 - position control (0 - 10 V, 4 - 20 mA)
Nominal force	4,6 a 7,2 kN
Travel	16, 25, 40 mm
Enclosure	IP 65
Proces medium max. temperature	Acc. to used valve
Ambient temperature range	-25 to 55° C
Ambient humidity range	5 - 100% with condensation
Weight	5,4 to 8 kg

Dimensions of actuators

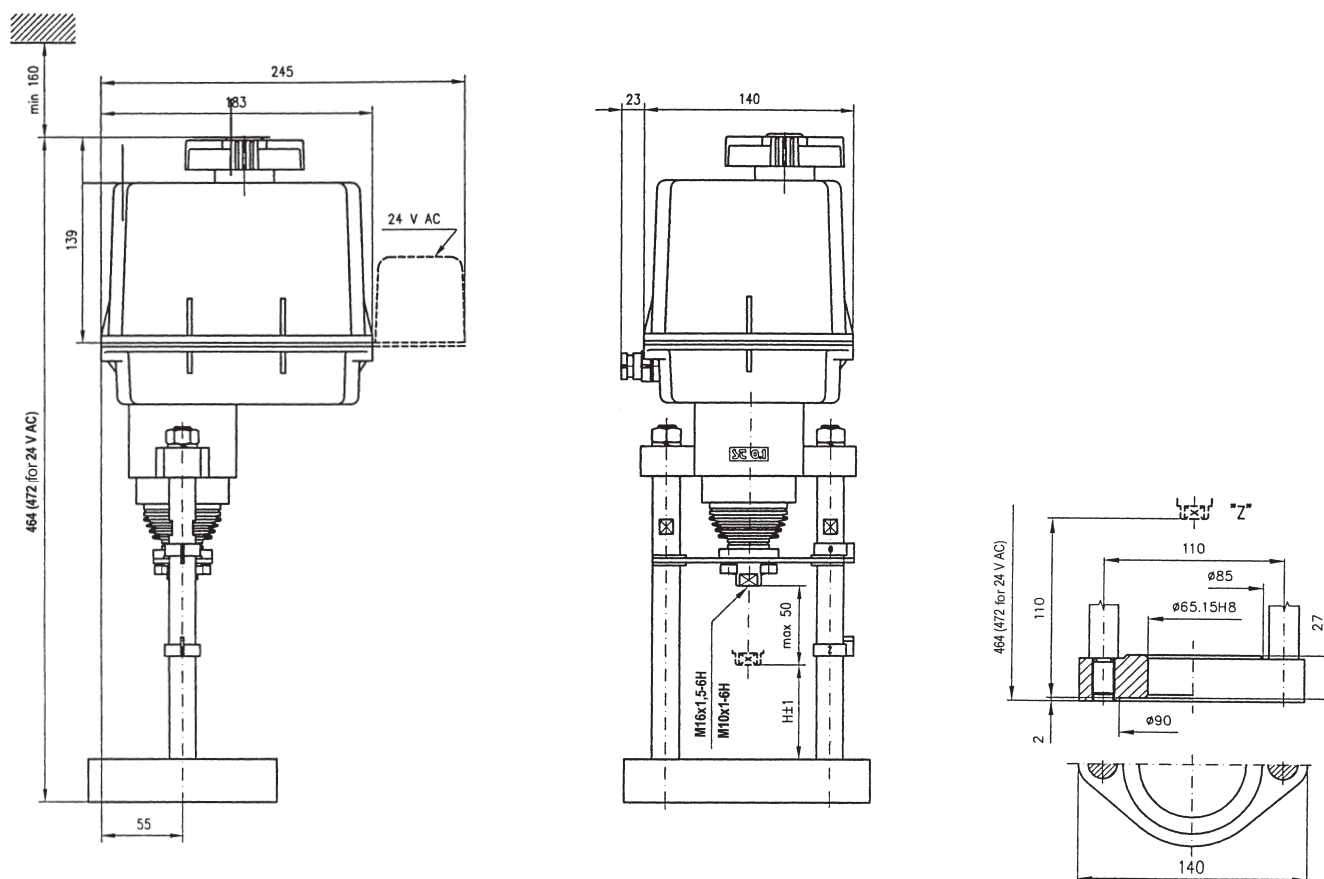

Specification of actuator ST 0.1

Electric actuator Isomact ST 0.1						498.	X	-	X	X	X	X	X	/	X	X												
Resistance to surroundings - standard		Normal execution (without positioner)				0																						
		With positioner		Resistance feedback	Wiring diagram Z237	A																						
				Current feedback	Wiring diagram Z242	C																						
Electric connection		Terminal board		Wiring diagram Z33		Voltage		230 V AC	0																			
						24 V AC		3																				
						3x400 V AC		9																				
Nominal force [N]	4600		Running speed	10 mm/min		Motor power	15 W										G											
				16 mm/min																	H							
				25 mm/min																		I						
				32 mm/min																			J					
				40 mm/min																			K					
	7200			10 mm/min																		T						
				16 mm/min																		U						
				25 mm/min																			V					
				32 mm/min																			W					
				40 mm/min																				Y				
Tripping torque Two-torque				Travel		16 mm											D											
						25 mm														F								
						40 mm															H							
Remote position transmitter		Without transmitter															A											
		Resistance		Single		1 x 100 Ω		Z22										B										
				Double ⁶⁾		1 x 2000 Ω														F								
		Electronic - current		Wiring		2 - wire		Z32											K									
						2 - wire ⁶⁾				2 x 100 Ω											P							
						Wo. its source		3 - wire ⁶⁾		4 - 20 mA		Z23									S							
						With its source		3 - wire ⁶⁾		0 - 20 mA				Z269									Q					
		Wo. its source		3 - wire ⁶⁾		4 - 20 mA		Z257										T										
		With its source		3 - wire ⁶⁾		4 - 20 mA		Z260										U										
		Wo. its source		3 - wire ⁶⁾		4 - 20 mA		Z257											V									
		With its source		3 - wire ⁶⁾		4 - 20 mA		Z260											W									
		Capacity		Wiring		2 - wire ⁶⁾		Z46											I									
2 - wire						4 - 20 mA				Z45										J								
With its source ⁵¹⁾						2 - wire				Z242																		
Mechanical connection - flange, connecting height 110 mm, thread on con. stem M10x1 or M16x1,5																												C
Accessories		A 2 auxiliary position switches				Wiring diagram Z21												0	0									
		B 2 auxiliary position switches				Wiring diagram Z1a, Z78a													0	1								
		C Heater without thermal sensor				Wiring diagram Z270, Z90a														0	3							
		D Manual ctrl without permanent standby				---															0	5						

Notes:

6) Valid for the version without any positioner

51) For a version with with current feedback only. The output signal from the capacitive transmitter is not galvanically insulated from the input signal

Wiring diagram for actuator Isomact ST 0.1

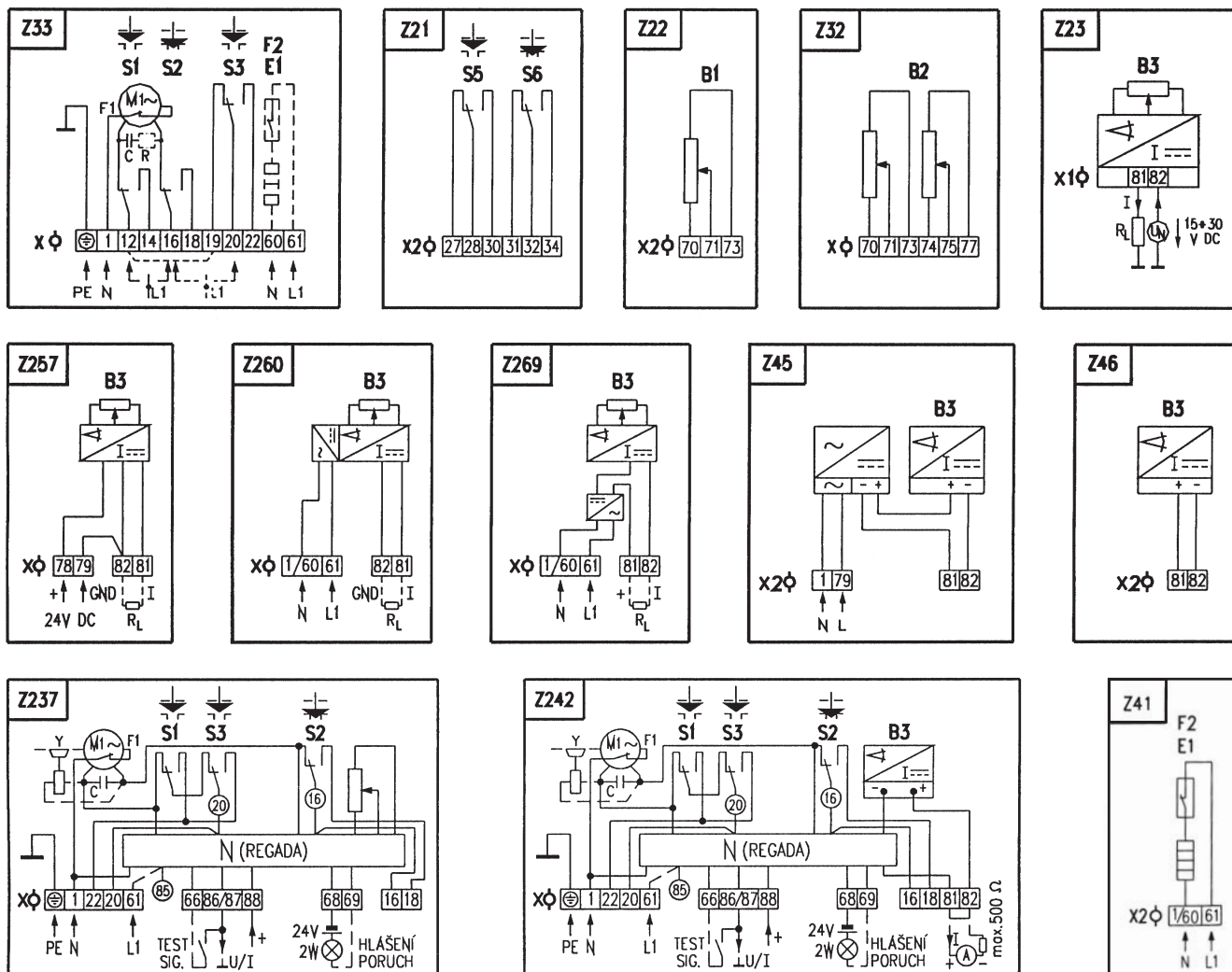

- B1 remote position transmitter - resistance, single
- B2 remote position transmitter - resistance, double
- B3 resistance transmitter with converter
- S1 power switch for "open" position
- S2 power switch for "closed" position
- S3 position switch for "open" position
- S4 position switch for "closed" position
- S5 additional limit switch for "open" position
- S6 additional limit switch for "closed" position
- M1 single-phase electromotor
- C capacitor
- E1 heater
- F1 heat protection of electromotor
- F2 thermostatic switch of heater
- X, X1, X2 terminal board
- N positioner
- I(U) input and feedback current (voltage) signals
- R loading resistance
- RL ballast resistor



Electric actuators Isomact ST 1-Ex Regada

Technical data

Type	ST 1-Ex
Marking in valve specification No.	EPJ
Voltage	230 V
Frequency	50 / 60 Hz
Motor power	15 W
Control	3 - position control, with positioner 0 - 10 V; (0) 4 - 20 mA
Nominal force	7,5 kN
Travel	16, 25, 40 mm
Enclosure	IP 54
Proces medium max. temperature	Acc. to used valve
Ambient temperature range	-25 to 55°C
Ambient humidity range	5 - 100 % with condensation
Weight	15 kg

Dimensions of actuators

Columns

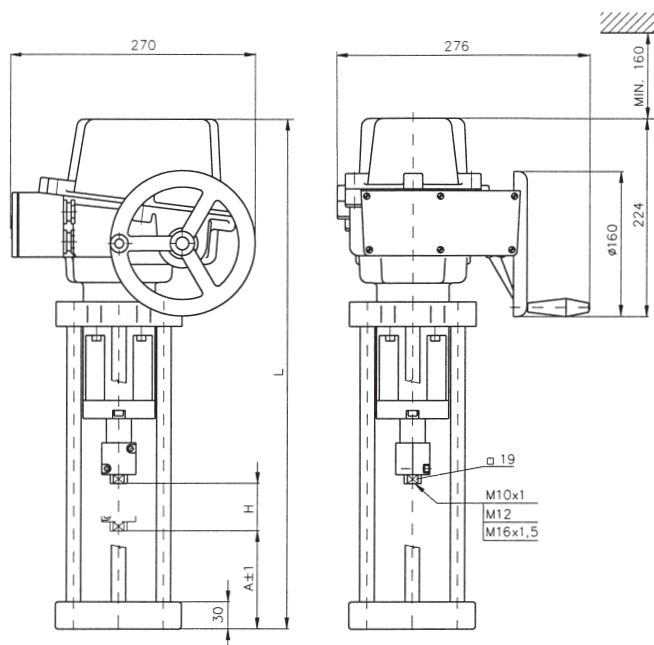

Type D

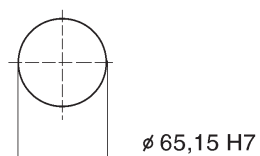

A	H	L	Connection flange type
110	50	576	D

Specification of actuator Isomact ST 1-Ex

Electric actuator Isomact ST 1-Ex			411.	X	-	X	X	X	X	X	X				
Resistance to surroundings -standard	Normal execution (without positioner)		0												
	With positioner	Resistance feedback transmitter	Wiring diagram Z249	A											
		Resistance feedback transmitter	Wiring diagram Z248	C											
Electric connection	Terminal board	Voltage	230 V AC					0							
			24 V AC					3							
			400 V AC ⁶⁾						9						
Nominal force [N]	Running speed	Voltage	8 mm/min					0							
			16 mm/min					1							
			32 mm/min					2							
			10 mm/min					5							
			20 mm/min					6							
			40 mm/min					7							
Maximal stroke (without transmitter) acc. to mechanical connection [mm]. Stroke can be adjusted in range from 0 to max. stroke value in actuators without transmitter			50							D					
Remote position transmitter	Without transmitter		Wiring diagram	16 mm							D				
	Resistance	Jednoduchý		25 mm								F			
				40 mm								H			
		Dvojitý ^{6) 56)}		P-1768								A			
	Electronic - current	Bez zdroje		Wiring	Feedback	P-1766							B		
						Z6a								F	
						74080700									K
		Se zdrojem				Z336									P
						Z258									S
						Z261									Q
	Capacity	Se zdrojem ⁵¹⁾		2 - vodič ⁶⁾	4 - 20 mA	Z258							T		
						Z261									U
74080700													V		
2 - vodič ⁶⁾	4 - 20 mA	74080600									W				
		Z248									I				
		J													

Mechanical connection - flange, connecting height 110 mm, thread on con. stem M10x1 or M16x1,5

Notes:

6) Platí jen v provedení bez regulátoru

51) Jen provedení s regulátorem s proudovou zpětnou vazbou

V tomto provedení není výstupní signál galvanicky oddělený od vstupního signálu

56) Platí jen pro provedení bez přídatných polohových spínačů S5, S6 pro 24 V AC

Schéma zapojení pohonů

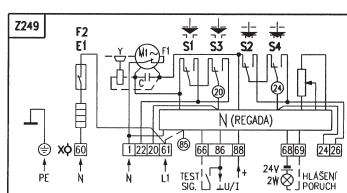
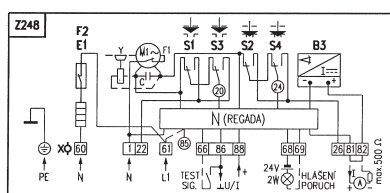
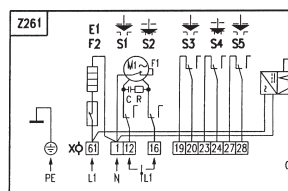
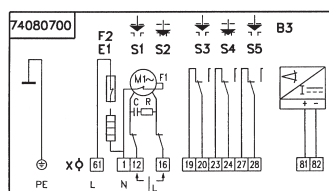
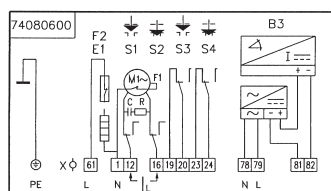
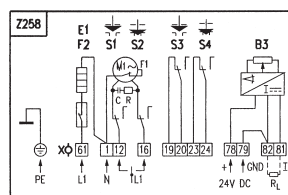
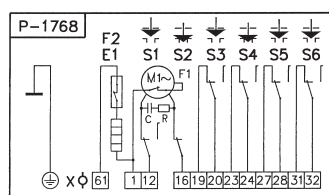
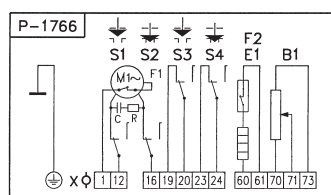

- B1 resistance transmitter 1x100Ω
- B3 position transmitter single-phase
- M1 electromotor
- C capacitor
- N positioner
- E1 heater
- F1 heat protection of electromotor
- F2 thermostatic switch of heater
- X terminal board
- R resistance
- S1 power switch for "open" position
- S2 power switch for "closed" position
- S3 position switch for "open" position
- S4 position switch for "closed" position
- S5 limit switch for "open" position
- S6 limit switch for "closed" position



Electric actuators ST 2, STR 2 Regada

Technical data

Type	ST 2, STR 2
Marking in valve specification No.	EPM
Voltage	230 V AC, 3x400 V AC
Frequency	50 / 60 Hz
Motor power	see specification table
Control	3 - position control with positioner 0 - 10 V, (0) 4 - 20 mA
Nominal force	16 a 25 kN
Travel	40 a 80 mm
Enclosure	IP 65
Proces medium max. temperature	Acc. to used valve
Ambient temperature range	-25 to 55°C
Ambient humidity range	5 - 100% with condensation
Weight	17 to 21 kg

Dimensions of actuators

RV 2xx DN 80 to 150 (Connection D)

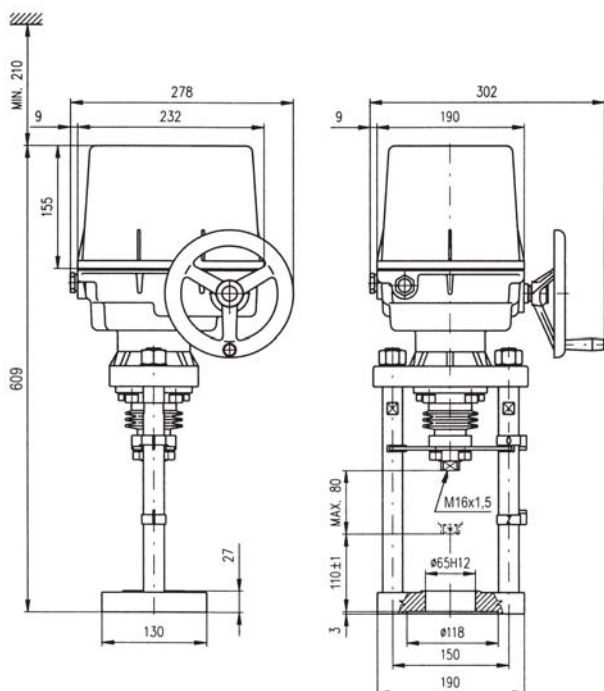

RV 2xx DN 200 to 300 (Connection M)

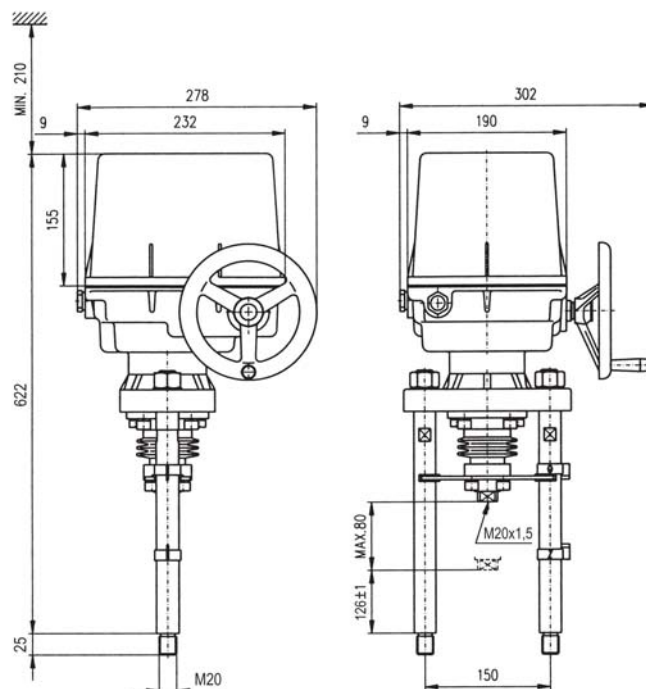

Specification of actuator ST 2

Electric actuator Isomact ST 2				492.	X	-	X	X	X	X	X	X	/	X	X											
Resistance to surroundings	Normal execution (without positioner) ST2				0																					
	With positioner STR2	Resistance feedback transmitter	Wir. diag. Z240a (230 V AC)		A																					
		Current feedback transmitter	Wir. diag. Z251a (3x400 V AC)																							
	Electric connection	To terminal board	Wiring diagram	Z344	Wiring diagram	C	24 V DC ⁴⁾										A									
Z1a + Z11a - bez N				230 V AC															0							
Z303 + Z12a - bez N				3x400 V AC ¹⁾²⁾																	2					
Z348b				24 V AC																	3					
Z78a + Z12a - bez N				3x400 V AC ¹⁾ - bez N																	9					
Z344				24 V DC ⁴⁾																		C				
To connector		Wiring diagram	Z1a + Z11a - bez N	Wiring diagram	C	230 V AC												5								
			Z348b			24 V AC														8						
			Z303 + Z12a - bez N			3x400 V AC ¹⁾²⁾															6					
			Z78a + Z12a - bez N			3x400 V AC ¹⁾ - bez N																7				
			230 V AC			3x400 V AC																				
			Nominal force [N] ³⁾			20 W	Nominal force [N] ³⁾	Motor power	90 W	Running speed	10 mm/min											A				
19 000 - 25 000	---																				J					
12 000 - 16 000	---																						B			
19 000 - 25 000	19 000 - 25 000																							L		
12 000 - 16 000	12 000 - 16 000																							C		
19 000 - 25 000	19 000 - 25 000																								R	
60 W	Nominal force [N] ³⁾	Motor power		90 W	Running speed	40 mm/min												D								
							12 000 - 16 000	---														V				
							---	12 000 - 16 000																W		
							12 000 - 16 000	---																	E	
							---	12 000 - 16 000																		Y
							12 000 - 16 000	12 000 - 16 000																		Z
Operating stroke	Max. Without transmitter ⁵⁾⁶⁾ ... 80 mm	With transmitter	40 mm														H									
			64 mm															J								
			80 mm																K							
Remote position transmitter	Without transmitter																A									
	Resistance	Single	Wiring	Feedback	Wiring diagram	Z5a												B								
		Double ⁶⁾					1 x 100 Ω														F					
	Electronic - current	Wo. its source	2-wire	Feedback	Wiring diagram	Z6a	Z10a												K							
								With its source	2 x 100 Ω														P			
		With its source	3-wire ⁶⁾	Feedback	Wiring diagram	Z269a	Z257a	Z260a												S						
									Wo. its source	2 x 2000 Ω															Q	
		With its source	3-wire ⁶⁾	Feedback	Wiring diagram	Z257a	Z257a	Z260a													T					
									Wo. its source	4 - 20 mA																U
	With its source	3-wire ⁶⁾	Feedback	Wiring diagram	Z257a	Z257a	Z260a														V					
								Wo. its source	4 - 20 mA																	W
	With its source	3-wire ⁶⁾	Feedback	Wiring diagram	Z257a	Z257a	Z260a														Y					
Wo. its source								0 - 20 mA																	Z	
Capacity	Wo. its source	2-wire ⁶⁾	Wiring	Feedback	Wiring diagram	Z10a													I							
							With its source	2-wire	Feedback	Wiring diagram	Z269a	Z260a												J		
													With its source ⁷⁾	2-wire												
Mechanical connection	flange, connecting height 110 mm, thread on con. stem M10x1																	D								
	columns, connecting height 126 mm, thread on con. Stem M20x1,5																		M							
Accessories	A	2 auxiliary position switches		Wiring diagram	Z11a, Z12a, Z21a													0 0								
	E	Space heater with terminal switch			Z1a, Z78a, Z41a														0 2							
	C	Electric local control			Z270, Z90a, Z232a														0 7							
	D	Space heater			Z1a, Z78a, Z41a															1 5						
	F	1-phase electric motor with protection			Z1a															1 9						
	G	Adjustment of switching-off thrust for required valve																		2 5						

Notes: 1) For the EA version with additional position switches a double transmitter cannot be specified; 2) Version with reverse contacts; 3) Switching thrust from the given range is needed to state by words in the order. If not specified it is adjusted to the maximum value from the given range; 4) Not recommended for the version with controller; 5) The version without any transmitter can have adjusted its stroke from 0 up to maximum stroke (10 mm, 32 mm, 80 mm); 6) Valid for the version without any controller 7) For a version with a controller with currently feedback only. The output signal from the capacitive transmitter is not galvanically insulated from the input signal

Wiring diagram of actuator ST 4

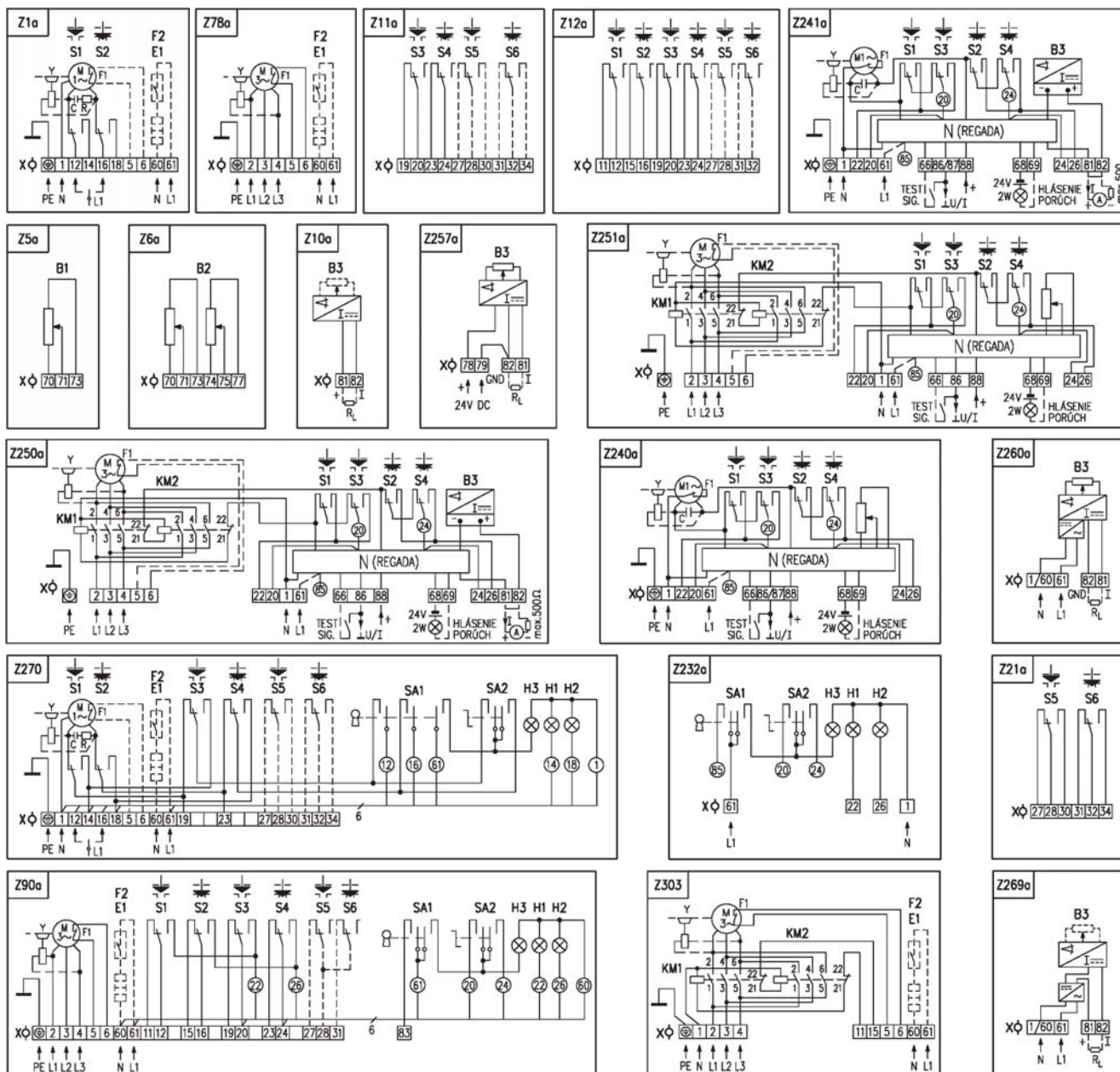

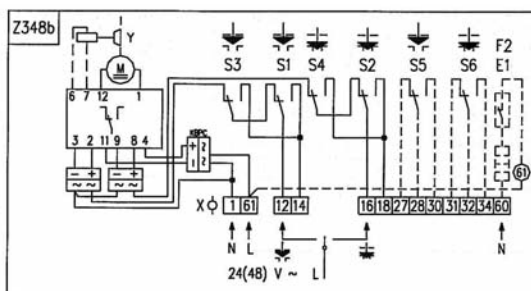
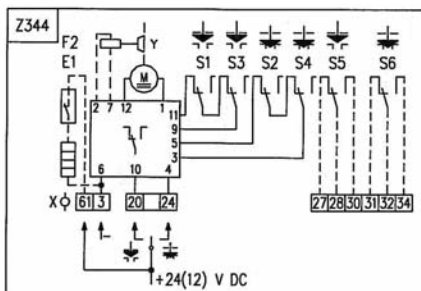
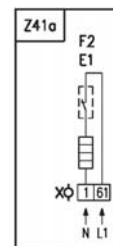
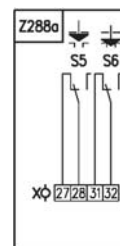
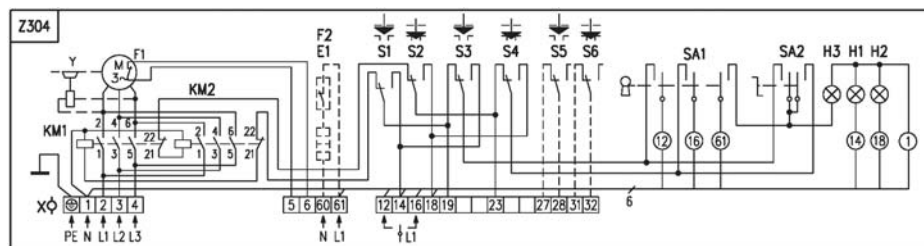

- | | | | |
|----|--|----------------|--|
| B1 | remote position transmitter - resistance, single | F1 | heat protection of electromotor |
| B2 | remote position transmitter - resistance, double | F2 | thermostatic switch of heater |
| B3 | resistance transmitter with converter | X | terminal board |
| S1 | power switch for "open" position | N | positioner |
| S2 | power switch for "closed" position | I(U) | input and feedback current (voltage) signals |
| S3 | position switch for "open" position | H1 | indication of "open" limit position |
| S4 | position switch for "closed" position | H2 | indication of "closed" limit position |
| S5 | additional limit switch for "open" position | H3 | indication of "electric local control" |
| S6 | additional limit switch for "closed" position | SA1 | rotary switch with key "remote - 0 - electric local" control |
| M | single-phase electromotor | SA2 | rotary switch with key "opening - stop - closing" |
| C | capacitor | R | loading resistance |
| Y | actuator brake | R _L | ballast resistor |
| E1 | heater | | |

Actuating of valves RV / UV 2x0, 2x2 a 2x4 with hand wheel

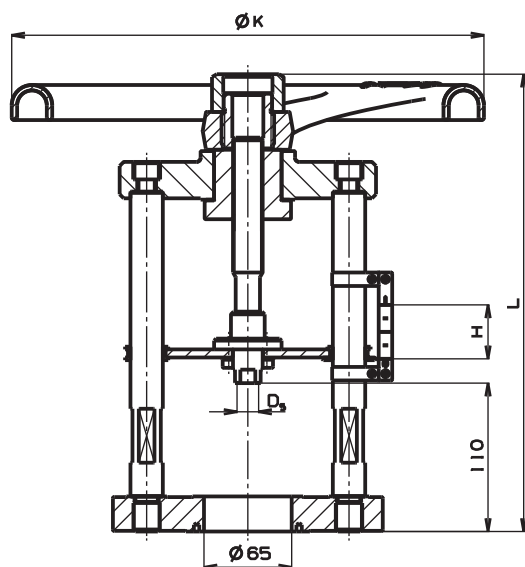

Hand wheel actuating of valves DN 15 - 150

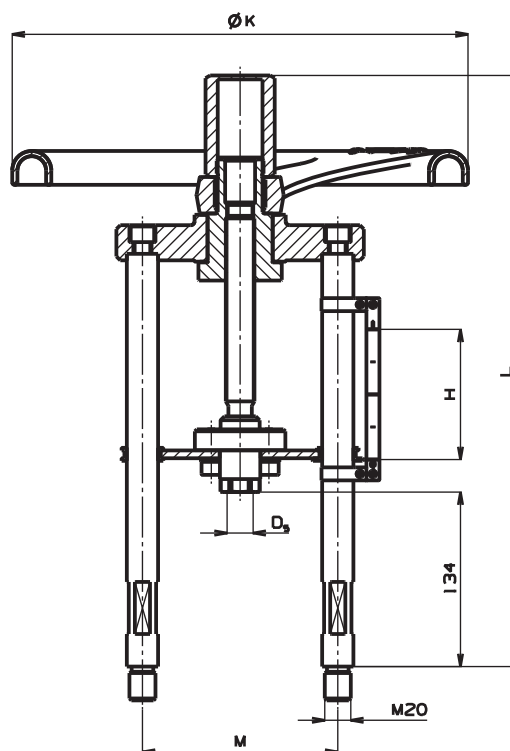

Hand wheel actuating of valves DN 200 - 400

Dimensions of hand wheel actuating:

DN	Marking	H mm	L mm	ØK mm	M mm	D _s mm	m kg	Ordering number (Part list number)				
15	R16	16	247	160	---	M10x1	5	S900 0231				
20												
25												
32												
40	R20	25	275	195	---	M16x1,5	11	S900 0115				
50												
65	R28	40	317	280	---	M16x1,5	13	S900 0116				
80												
100												
125	R35	80	339	350	150	M20x1,5	15	S900 0117				
150												
200			454					350	150	M20x1,5	15	S900 0141
250												
300												
400												

Maximal permissible operating pressures [MPa]

Material	PN	Temperature [°C]													
		RT ¹⁾	100	120	150	200	250	300	350	375	400	425	450	475	500
Brass 42 3135 (CuSn5Zn5Pb5-C)	16	1,60	1,60	1,60	1,14	---	---	---	---	---	---	---	---	---	---
		---	---	---	---	---	---	---	---	---	---	---	---	---	---
Grey cast iron EN-JL 1040 (EN-GJL-250)	16	1,60	1,60	1,60	1,44	1,28	---	---	---	---	---	---	---	---	---
		---	---	---	---	---	---	---	---	---	---	---	---	---	---
Spher.cast iron EN-JS 1025 (EN-GJS-400-18-LT)	16	1,60	1,60	1,60	1,55	1,47	1,39	1,28	1,12	---	---	---	---	---	---
	25	2,50	2,50	2,50	2,43	2,30	2,18	2,00	1,75	---	---	---	---	---	---
	40	4,00	4,00	4,00	3,88	3,68	3,48	3,20	2,80	---	---	---	---	---	---
Cast steel 1.0619 (GP240GH)	16	1,56	1,36	1,32	1,27	1,14	1,04	0,94	0,88	0,86	0,84	---	---	---	---
	25	2,44	2,13	2,07	1,98	1,78	1,62	1,47	1,37	1,35	1,32	---	---	---	---
	40	3,90	3,41	3,31	3,17	2,84	2,60	2,35	2,19	2,16	2,11	---	---	---	---
Chrommolybden 1.7357 (G17CrMo5-5)	16	1,63	1,63	1,61	1,58	1,49	1,43	1,33	1,23	1,20	1,15	1,11	1,07	1,00	0,89
	25	2,55	2,54	2,51	2,48	2,33	2,23	2,08	1,93	1,88	1,80	1,73	1,67	1,56	1,39
	40	4,08	4,07	4,02	3,96	3,74	3,57	3,33	3,09	3,00	2,89	2,77	2,67	2,50	2,23
Stainless steel 1.4581 (GX5CrNiMoNb19-11-2)	16	1,59	1,44	1,39	1,33	1,25	1,17	1,10	1,06	1,05	1,02	1,02	1,01	1,00	0,89
	25	2,49	2,25	2,18	2,08	1,95	1,84	1,72	1,66	1,63	1,60	1,59	1,58	1,56	1,39
	40	3,98	3,60	3,49	3,33	3,13	2,94	2,75	2,65	2,61	2,56	2,54	2,52	2,50	2,23
Stainless steel 1.4308 (GX5CrNi19-10)	16	1,52	1,17	1,12	1,06	0,96	0,89	0,83	0,79	0,77	0,74	0,74	0,72	0,71	0,70
	25	2,37	1,84	1,76	1,66	1,50	1,40	1,30	1,23	1,20	1,16	1,15	1,13	1,11	1,09
	40	3,79	2,94	2,82	2,65	2,41	2,24	2,08	1,97	1,91	1,86	1,84	1,80	1,78	1,74

¹⁾ -10°C to 50°C

Actuator marking in valve specification No.

Electric actuator PTN 2.20	E R B	Electric actuator Rotork IQM 7	E Q A
Electric actuator PTN 2.32; PTN 2.40	E R C	Electric actuator Rotork Ex IQM 7	E Q B
Electric actuator PTN 6	E R D	Electric actuator Schiebel AB3	E Z A
Electric actuator PTN 7	E R G	Electric actuator Schiebel exAB3	E Z B
Electric actuator 660 MIDI	E N B	Electric actuator Schiebel rAB3	E Z C
Electric actuator Zepadyn 670	E N C	Electric actuator Schiebel exrAB3	E Z D
Electric actuator Zepadyn 671	E N E	Electric actuator Schiebel AB5	E Z E
Electric actuator Modact MTR	E P D	Electric actuator Schiebel exAB5	E Z F
Electric actuator ST 0	E P K	Electric actuator Schiebel rAB5	E Z G
Electric actuator ST 0.1	E P L	Electric actuator Schiebel exrAB5	E Z H
Electric actuator Isomact ST 1 Ex	E P J	Electric actuator Schiebel rAB8	E Z K
Electric actuator Isomact ST 2	E P M	Electric actuator Schiebel exrAB8	E Z L
Electric actuator Modact MTN, MTP Control	E Y A	Electric actuator EMG Drehmo D 30	E D A
Electric actuator Modact MTN, MTP	E Y B	Electric actuator EMG Drehmo D R 30	E D B
Electric actuator Modact MTNED, MTPED	E Y A	Electric actuator EMG Drehmo DMI 30	E D C
Electric actuator Auma SA 07.1	E A A	Electric actuator EMG Drehmo DMI R 30	E D D
Electric actuator Auma SA Ex 07.1	E A B	Electric actuator EMG Drehmo D R 30 Ex	E D I
Electric actuator Auma SAR 07.1	E A C	Electric actuator EMG Drehmo DMI R 30 Ex	E D K
Electric actuator Auma SAR Ex 07.1	E A D	Hand wheel for DN 15 - 40	R 1 6
Electric actuator Auma SA 07.5	E A E	Hand wheel for DN 50 - 65	R 2 2
Electric actuator Auma SA Ex 07.5	E A F	Hand wheel for DN 80 - 100	R 2 8
Electric actuator Auma SAR 07.5	E A G	Hand wheel for DN 125 - 400	R 3 5
Electric actuator Auma SAR Ex 07.5	E A H		
Electric actuator Auma SA 10.1	E A I		
Electric actuator Auma SAR 10.1	E A J		
Electric actuator Auma SAR Ex 10.1	E A K		
Electric actuator Auma SA Ex 10.1	E A L		



LDM, spol. s r.o.
Litomyšlská 1378
560 02 Česká Třebová
Czech Republic

tel.: +420 465 502 511
fax: +420 465 533 101
E-mail: sale@ldm.cz
<http://www.ldm.cz>

LDM, spol. s r.o.
Office in Prague
Podolská 50
147 01 Praha 4

tel.: 241087360
fax: 241087192
E-mail: tomas.suchanek@ldm.cz

LDM, spol. s r.o.
Office in Ústí nad Labem
Ladova 2548/38
400 11 Ústí nad Labem
- Severní Terasa

tel.: 602708257
E-mail: tomas.kriz@ldm.cz

LDM servis, spol. s r.o.
Litomyšlská 1378
560 02 Česká Třebová
Czech Republic

tel.: +420 465 502 411-3
fax: +420 465 531 010
E-mail: servis@ldm.cz

LDM, Polska Sp. z o.o.
Modelarska 12
40 142 Katowice
Poland

tel.: +48 32 730 56 33
fax: +48 32 730 52 33
mobile: +48 601 354 999
E-mail: ldmpolska@ldm.cz

LDM Bratislava s.r.o.
Mierová 151
821 05 Bratislava
Slovakia

tel.: +421 2 43415027-8
fax: +421 2 43415029
E-mail: ldm@ldm.sk
<http://www.ldm.sk>

LDM - Bulgaria - OOD
z. k. Mladost 1
bl. 42, floor 12, app. 57
1784 Sofia
Bulgaria

tel.: +359 2 9746311
fax: +359 2 9746311
mobile: +359 888 925 766
E-mail: ldm.bg@ldmvalves.com

OOO "LDM Promarmatura"
Jubilejnyi prospekt,
dom.6a, of. 601
141400 Khimki Moscow Region
Russian Federation

tel.: +7 4957772238
fax: +7 4956662212
mobile: +7 9032254333
E-mail: inforus@ldmvalves.com

TOO "LDM"
Lobody 46/2
Office No. 4
100008 Karaganda
Kazakhstan

tel.: +7 7212 566 936
fax: +7 7212 566 936
mobile: +7 701 738 36 79
E-mail: sale@ldm.kz
<http://www.ldm.kz>

LDM Armaturen GmbH
Wupperweg 21
D-51789 Lindlar
Germany

tel.: +49 2266 440333
fax: +49 2266 440372
mobile: +49 177 2960469
E-mail: ldmarmaturen@ldmvalves.com
<http://www.ldmvalves.com>

Your partner