

**01 - 02.7**

02.14.GB

**Two-way and Three-way control valves LDM  
RV 113**



## Kv coefficient calculation

Calculation itself is carried out with respect to conditions of regulating circuit and operating medium according to equations mentioned below. Control valve must be designed to be able to regulate maximal flow quantity at given operating conditions. At the same time it is necessary to check whether minimal flow rate can be even regulated or not.

Condition is the following ratio  $r > Kvs / Kvs_{min}$

Because of possible minus tolerance 10% of  $Kvs_{100}$ , against  $Kvs$  and requirement for possible regulation within range of maximal flow (decrement and increase of flow), producer recommends to select  $Kvs$  value higher than maximal operating  $Kv$  value:

$$Kvs = 1.1 \div 1.3 Kv$$

It is necessary to take into account to which extent  $Q_{max}$  involve "precautionary additions" that could result in valve oversizing.

## Relations of Kv calculation

		Pressure drop $p_2 > p_1/2$ $\Delta p < p_1/2$	Pressure drop $\Delta p \geq p_1/2$ $p_2 \leq p_1/2$
Kv =	Liquid	$\frac{Q}{100} \sqrt{\frac{\rho_1}{\Delta p}}$	
	Gas	$\frac{Q_n}{5141} \sqrt{\frac{\rho_n \cdot T_1}{\Delta p \cdot p_2}}$	$\frac{2 \cdot Q_n}{5141 \cdot p_1} \sqrt{\rho_n \cdot T_1}$

## Flow characteristic selection in regard of valve stroke

To make right selection of valve flow characteristic, it is suitable to carry out checking of what stroke values will be reached in different operation states. We recommend to carry out such checking at least for minimal, nominal and maximal flow rates. The principle for flow characteristic selection is to avoid, if possible, 5÷10% of the beginning and end of the valve stroke range.

To calculate valve stroke at different operating conditions with different types of flow characteristics is possible with the advantage of using LDM's calculation programme VALVES. The programme serves for complete design of valve from  $Kv$  calculation to specification of a concrete valve with its actuator.

## Valve flow characteristics

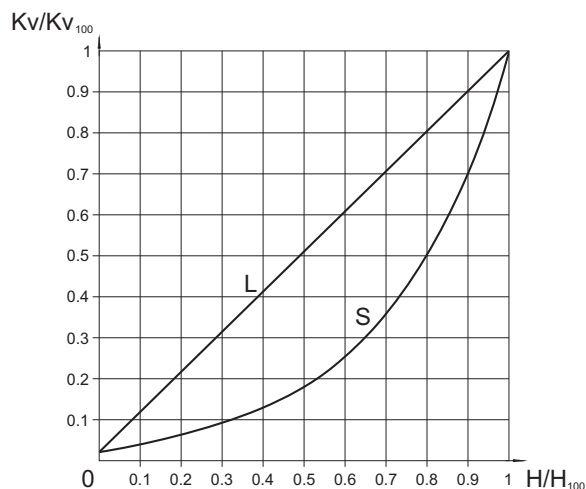

L - linear characteristic

$$Kv/Kv_{100} = 0.0183 + 0.9817 \cdot (H/H_{100})$$

S - LDMspline® characteristic

$$Kv/Kv_{100} = 0.0183 + 0.269 \cdot (H/H_{100}) - 0.380 \cdot (H/H_{100})^2 + 1.096 \cdot (H/H_{100})^3 - 0.194 \cdot (H/H_{100})^4 - 0.265 \cdot (H/H_{100})^5 + 0.443 \cdot (H/H_{100})^6$$

## Packing - O - ring EPDM

Well proven type of packing with sealing elements made of high quality EPDM is suitable for operating with temperature of +2 to +150°C. The packing excels with its reliability and long time tightness. Its properties ensure safe usage in nonmaintenance applications. Main preferences of the packing is low frictional forces, sealing capability in both ports (even when there is underpressure in the valve) and service life exceeding 500 000 cycles.

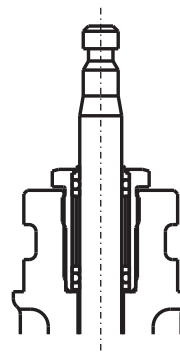

## Dimensions and units

Marking	Unit	Name of dimension
Kv	$m^3 \cdot h^{-1}$	Flow coefficient under conditions of units of flow
$Kv_{100}$	$m^3 \cdot h^{-1}$	Flow coefficient at nominal stroke
$Kv_{min}$	$m^3 \cdot h^{-1}$	Flow coefficient at minimal flow rate
Kvs	$m^3 \cdot h^{-1}$	Valve nominal flow coefficient
Q	$m^3 \cdot h^{-1}$	Flow rate in operating conditions ( $T_1, p_1$ )
$Q_n$	$Nm^3 \cdot h^{-1}$	Flow rate in normal conditions (0°C, 0.101 Mpa)
$p_1$	MPa	Upstream absolute pressure
$p_2$	MPa	Downstream absolute pressure
$p_s$	MPa	Absolute pressure of saturated steam at given temperature ( $T_1$ )
$\Delta p$	MPa	Valve differential pressure ( $\Delta p = p_1 - p_2$ )
$\rho_1$	$kg \cdot m^{-3}$	Process medium density in operating conditions ( $T_1, p_1$ )
$\rho_n$	$kg \cdot Nm^{-3}$	Gas density in normal conditions (0°C, 0.101 Mpa)
$T_1$	K	Absolute temperature at valve inlet ( $T_1 = 273 + t_1$ )
r	1	Rangeability

## Simplified procedure for designing of two-way control valve

Given: medium water, 115°C, static pressure at piping spot 600 kPa (6 bar),  $\Delta p_{AVAIL} = 40$  kPa (0,4 bar),  $\Delta p_{PIPELINE} = 7$  kPa (0,07 bar),  $\Delta p_{APPLIANCE} = 15$  kPa (0,15 bar), nominal flow rate  $Q_{NOM} = 36$  m<sup>3</sup>·h<sup>-1</sup>, minimal flow rate  $Q_{MIN} = 2,4$  m<sup>3</sup>·h<sup>-1</sup>.

$$\Delta p_{AVAIL} = \Delta p_{VALVE} + \Delta p_{APPLIANCE} + \Delta p_{PIPELINE}$$

$$\Delta p_{VALVE} = \Delta p_{AVAIL} - \Delta p_{APPLIANCE} - \Delta p_{PIPELINE} = 40 - 15 - 7 = 18 \text{ kPa (0,18 bar)}$$

$$Kv = \frac{Q_{NOM}}{\sqrt{\Delta p_{VALVE}}} = \frac{36}{\sqrt{0,18}} = 84,85 \text{ m}^3 \cdot \text{h}^{-1}$$

Precautionary additions for process tolerances (provided that flow rate Q was not oversized):

$$Kvs = (1,1 \text{ to } 1,3) \cdot Kv = (1,1 \text{ to } 1,3) \cdot 84,85 = 93,3 \text{ to } 110,3 \text{ m}^3 \cdot \text{h}^{-1}$$

Now we choose the nearest Kvs value from those available in our catalogue, i.e. Kvs = 100 m<sup>3</sup>·h<sup>-1</sup>. This value corresponds to nominal size of DN 80. Then if we choose flanged valve PN 16 made of grey cast iron, we will get the following specification No.:

**RV 113 R 4331 16/150-80**

Then we select an appropriate actuator according to the regulation demands.

## Determination of real pressure drop value of a chosen valve at fully open with given flow rate

$$\Delta p_{VALVE H100} = \left( \frac{Q_{NOM}}{Kvs} \right)^2 = \left( \frac{36}{100} \right)^2 = 0,123 \text{ bar (12,3 kPa)}$$

Scheme of typical regulation loop with the application of two-way control valve

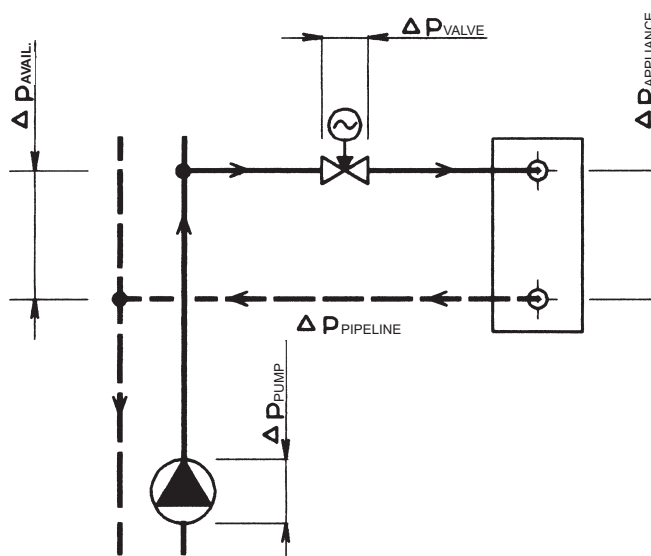

Remark: More detailed information on calculation and design of LDM control valves is mentioned in calculation instructions No. 01-12.0. Equations mentioned above apply in a simplified way to water. To reach optimum results, we recommend to use original calculation programme VALVES which is available on request free of charge.

The control valve's real pressure drop calculated this way shall be taken into account in a hydraulic calculation of regulating circuit.

## Determination of valve's real authority

$$a = \frac{\Delta p_{VALVE H100}}{\Delta p_{VALVE H0}} = \frac{12,3}{40} = 0,31$$

Value  $\underline{a}$  should be at least equal to 0,3. A chosen valve checking is then satisfactory.

**Caution:** the valve's authority calculation should be related to a valve pressure difference in its closed position i.e. disposition pressure value in a branch  $\Delta p_{AVAIL}$  when flow rate is zero, not to a pressure value of a pump  $\Delta p_{PUMP}$ , because, due to pipeline circuit pressure drops up to the spot where the regulating branch is connected, the following equation applies:  $\Delta p_{AVAIL} < \Delta p_{PUMP}$ . In such cases we consider for simplicity the following:  $\Delta p_{AVAIL H100} = \Delta p_{AVAIL H0} = \Delta p_{DISP}$ .

## Checking of rangeability

We carry out the same checking for minimal flow rate  $Q_{MIN} = 2,4$  m<sup>3</sup>·h<sup>-1</sup>. The following differential pressure values correspond to the min. flow rate:  $\Delta p_{PIPELINE QMIN} = 0,40$  kPa,  $\Delta p_{APPLIANCE QMIN} = 0,66$  kPa.  $\Delta p_{AVAIL QMIN} = 40 - 0,4 - 0,66 = 38,94 = 39$ .

$$Kv_{MIN} = \frac{Q_{MIN}}{\sqrt{\Delta p_{VALVE QMIN}}} = \frac{2,4}{\sqrt{0,39}} = 3,84 \text{ m}^3 \cdot \text{h}^{-1}$$

Necessary rangeability value

$$r = \frac{Kvs}{Kv_{MIN}} = \frac{100}{3,84} = 26$$

shall be lower than mentioned rangeability value of  $r = 50$ . Checking is then satisfactory.

## Procedure for designing of three-way mixing valve

Given: medium water, 90°C, static pressure at piping spot 600 kPa (6 bar),  $\Delta p_{\text{PUMP2}} = 35 \text{ kPa}$  (0,35 bar),  $\Delta p_{\text{PIPELINE}} = 10 \text{ kPa}$  (0,1 bar),  $\Delta p_{\text{APPLIANCE}} = 20 \text{ kPa}$  (0,2 bar), nominal flow rate  $Q_{\text{NOM}} = 12 \text{ m}^3 \cdot \text{h}^{-1}$

$$\Delta p_{\text{PUMP2}} = \Delta p_{\text{VALVE}} + \Delta p_{\text{APPLIANCE}} + \Delta p_{\text{PIPELINE}}$$

$$\Delta p_{\text{VALVE}} = \Delta p_{\text{PUMP2}} - \Delta p_{\text{APPLIANCE}} - \Delta p_{\text{PIPELINE}} = 35 - 20 - 10 = 5 \text{ kPa} (0,05 \text{ bar})$$

$$Kv = \frac{Q_{\text{NOM}}}{\sqrt{\Delta p_{\text{VALVE}}}} = \frac{12}{\sqrt{0,05}} = 53,67 \text{ m}^3 \cdot \text{h}^{-1}$$

Precautionary additions for process tolerances (provided that flow rate Q was not oversized):

$$Kvs = (1,1 \text{ to } 1,3) \cdot Kv = (1,1 \text{ to } 1,3) \cdot 53,7 = 59,1 \text{ to } 69,8 \text{ m}^3 \cdot \text{h}^{-1}$$

Now we choose the nearest Kvs value from those available in our catalogue, i.e.  $Kvs = 63 \text{ m}^3 \cdot \text{h}^{-1}$ . This value corresponds to nominal size of DN 65. Then if we choose threaded valve PN 16 made of grey cast iron, we will get the following specification No.:

**RV 113 M 6331-16/150-65**

Then we select an appropriate actuator according to the regulation demands.

Scheme of typical regulation loop with the application of three-way control valve

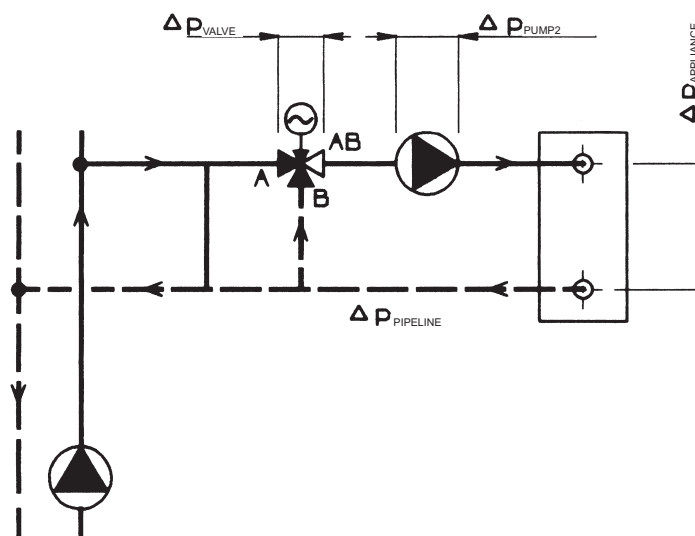

Remark: More detailed information on calculation and design of LDM control valves is mentioned in calculation instructions No. 01-12.0. Equations mentioned above apply in a simplified way to water. To reach optimum results, we recommend to use original calculation programme VALVES which is available on request free of charge.

## Determination of real pressure drop value of a chosen valve at fully open

$$\Delta p_{\text{VALVE H100}} = \left( \frac{Q_{\text{NOM}}}{Kvs} \right)^2 = \left( \frac{12}{63} \right)^2 = 0,036 \text{ bar} (3,6 \text{ kPa})$$

The control valve's real pressure drop calculated this way shall be taken into account in a hydraulic calculation of regulating circuit.

**Caution:** To ensure reliable function of three-way valves, the most important condition is to keep minimum available pressure difference between A and B ports. Three-way valves are capable to manage even high pressure difference between A and B ports but valve's flow characteristic deforms then and so regulation properties deteriorate. So if in doubt about pressure difference value between those two ports (e.g. when three-way valve is piped directly into primary side without pressure separation), we recommend to use a two-way valve in combination with a primary-secondary side short cut to ensure a reliable regulation.

# RV 113 R



**Two-way control valves**  
**DN 15 - 150, PN 16**  
**DN 15 - 40, PN 6**

## Description

Control valves RV 113 R are flanged, 2-way valves with pressure balanced plug (except DN 15 - 25) and high tightness designed for regulation and closing of the medium flow. Its design enables the valve to be applicable at high differential pressures with low-linear-force actuators. Owing to unique flow characteristic LDMspline®, optimized for regulation of thermodynamic processes, the valves are ideal for applications in heating and air-conditioning.

Flow characteristics, Kvs values and leakage rates correspond to international standards.

The valves type RV 113 R have connection to the following actuators: Siemens, Belimo, Ekorex and LDM.

## Application

Control valves RV113 are designed for applications in heating and air-conditioning. Control valves type RV113 are also available in silicone free execution (marking in a specification number SF). The maximum permissible operating pressures are specified below on this page.

## Technical data

Series	RV 113 R	
Type of valve	Three-way control valve	
Nominal size range	DN 15 to 150	
Nominal pressure	DN 15 - 150, PN 16; DN 15 - 40, PN 6	
Body material	Grey cast iron EN-JL 1040	
Plug material	Stainless steel 1.4027 (1.4028)	
Stem material	Stainless steel 1.4305	
Seat sealing	EPDM	
Packing	EPDM	
Operating temperature range	+2 to +150°C	
Connection	Flanges type B1 (raised-faced) Acc. to ČSN-EN 1092-2 (4/2002)	
Face to face dimensions	Series 1 acc. to ČSN-EN 558 (9/2008)	
Type of plug	V-ported with soft seat sealing	
Flow characteristic	LDMspline®	
Kvs values	1,6 to 360 m <sup>3</sup> /h	
Leakage rate	Class IV. - S1 acc. to ČSN-EN 1349 (5/2001) (<0.0005 % Kvs)	
Rangeability r	50 : 1	

## Maximum permissible operating pressures [ MPa]

Material	PN	Temperature [°C]										
		120	150	200	250	300	350	400	450	500	525	550
Grey cast iron EN-JL 1040 (EN-GJL-250)	16	1,60	1,44	---	---	---	---	---	---	---	---	---
	6	0,60	0,54	---	---	---	---	---	---	---	---	---

## Kvs values and differential pressures

The value  $\Delta p_{\max}$  is maximum differential pressure when reliable closing and opening is guaranteed.

Because of the seat and plug service life, it is recommended so that permanent differential pressure would not exceed 0.4 MPa.

For further info. on actuating see actuators' catalogue sheets		Actuating (actuator)			Siemens	Belimo				Ekorex			LDM	
DN	H	Linear force			700 N	800 N	1600 N	2000 N	2000 N	3200 N	4000 N	2000 N	2500 N	
		Kvs [m <sup>3</sup> /h]			$\Delta p_{\max}$	$\Delta p_{\max}$	$\Delta p_{\max}$	$\Delta p_{\max}$	$\Delta p_{\max}$	$\Delta p_{\max}$	$\Delta p_{\max}$	$\Delta p_{\max}$	$\Delta p_{\max}$	
		1	2	3	MPa	MPa	MPa	MPa	MPa	MPa	MPa	MPa	MPa	
<b>PN 6</b>														
15	20	4	2.5	1.6	0.60	0.60	0.60	---	0.60	---	---	0.60	0.60	
20		6.3	---	---	0.60	0.60	0.60	---	0.60	---	---	0.60	0.60	
25		10	---	---	0.60	0.60	0.60	---	0.60	---	---	0.60	0.60	
32		16	---	---	0.60	0.60	0.60	---	0.60	---	---	0.60	0.60	
40		25	---	---	0.60	0.60	0.60	---	0.60	---	---	0.60	0.60	
<b>PN 16</b>														
15	20	4	2.5	1.6	1.60	1.60	1.60	---	1.60	---	---	1.60	1.60	
20		6.3	---	---	1.35	1.60	1.60	---	1.60	---	---	1.60	1.60	
25		10	---	---	0.86	1.03	1.60	---	1.60	---	---	1.60	1.60	
32		16	---	---	1.60	1.60	1.60	---	1.60	---	---	1.60	1.60	
40		25	---	---	1.60	1.60	1.60	---	1.60	---	---	1.60	1.60	
50		40.0	---	---	1.60	1.60	1.60	---	1.60	1.60	1.60	1.60	1.60	
65		63.0	---	---	1.60	1.60	1.60	---	1.60	1.60	1.60	1.60	1.60	
80	100.0	---	---	1.60	1.60	1.60	---	1.60	1.60	1.60	1.60	1.60		
100	40	160.0	---	---	---	---	---	1.60	1.60	1.60	1.60	1.60	1.60	
125		250.0	---	---	---	---	---	1.60	1.60	1.60	1.60	1.60	1.60	
150		360.0	---	---	---	---	---	1.60	1.60	1.60	1.60	1.60	1.60	

## Supplied types of actuators

			stroke	
Siemens	Electric actuator SQX 32.00 a SQX 32.03	AC 230 V, 3-position control, 700 N	20 mm	
	Electric actuator SQX 82.00 a SQX 82.03	AC 24 V, 3-position control, 700 N		
	Electric actuator SQX 62	AC 24 V, control 0...10V, 4...20mA, 700 N		
Belimo	Electric actuator NV24-3	AC/DC 24 V, 3-position control, 800 N	20 mm	
	Electric actuator NV230-3	AC 230 V, 3-position control, 800 N		
	Electric actuator NVF24-MFT	AC/DC 24 V, 3-position control, ON-OFF, 0...10V fail-safe function - indirect, 800 N		
	Electric actuator NVF24-MFT-E	AC/DC 24 V, 3-position control, ON-OFF, 0...10V fail-safe function - direct, 800 N		
	Electric actuator NV24-MFT	AC/DC 24 V, 3-position control, 0...10V, 800 N		
	Electric actuator Nvy24-MFT	AC/DC 24 V, 3-position control, 0...10V, 800 N quick running time 35 s,		
	Electric actuator NVG24-MFT	AC/DC 24 V, 3-position control, 0...10V, 1600 N		
	Electric actuator AV24-3	AC/DC 24 V, 3-position control, 2000 N		
	Electric actuator AV230-3	AC 230 V, 3-position control, 2000 N		
Ekorex	Electric actuator AV24-MFT	AC 24 V, 3-position control, 0...10V, 2000 N	40 mm	
	Electric actuator AVY24-MFT	AC 230 V, 3-position control, 0...10V, 2000 N quick running time 60 s		
	Electric actuator PTN2-XX.0	AC 230 V, 3-position control, 0...10V, 4...20mA		20 - 40 mm
	Electric actuator PTN2-XX.2	AC 24 V, 3-position control, 0...10V, 4...20mA		
	LDM	Electric actuator ANT40.11		AC/DC 24 V (230 V with modul), 2500 N 3(2)-position control, 0...10V, 4...20mA
Electric actuator ANT40.11S		AC/DC 24 V (230 V s modulem), 2000 N 3(2)-position control, 0...10V, 4...20mA fail-safe function - indirect		
Electric actuator ANT40.11R		AC/DC 24 V (230 V s modulem), 2000 N 3(2)-position control, 0...10V, 4...20mA fail-safe function - direct		

## Dimensions and weights for the type RV 113 R

PN 6

DN	D <sub>1</sub>	D <sub>2</sub>	D <sub>3</sub>	d	n	a	f	D <sub>4</sub>	L	V	V <sub>1</sub>	V <sub>2</sub>	H	m
	mm	mm	mm	mm	mm	mm	mm	mm	mm	mm	mm	mm	mm	kg
15	80	55	38	11	4	12	2	44	130	147	65	96	20	2.6
20	90	65	48	11	4	14	2	44	150	147	75	96	20	3.5
25	100	75	58	11	4	14	3	44	160	147	80	96	20	4.1
32	120	90	69	14	4	16	3	44	180	157	90	96	20	6.3
40	130	100	78	14	4	16	3	44	200	167	100	96	20	7.9

PN 16

DN	D <sub>1</sub>	D <sub>2</sub>	D <sub>3</sub>	d	n	a	f	D <sub>4</sub>	L	V	V <sub>1</sub>	V <sub>2</sub>	H	m
	mm	mm	mm	mm	mm	mm	mm	mm	mm	mm	mm	mm	mm	kg
15	95	65	46	14	4	14	2	44	130	147	65	96	20	3.5
20	105	75	56	14	4	16	2	44	150	147	75	96	20	4.6
25	115	85	65	14	4	16	3	44	160	147	80	96	20	5.4
32	140	100	76	19	4	18	3	44	180	157	90	96	20	8.5
40	150	110	84	19	4	18	3	44	200	167	100	96	20	10.5
50	165	125	99	19	4	20	3	44	230	182	155	96	20	16.7
65	185	145	118	19	4	20	3	44	290	192	185	96	20	23.0
80	200	160	132	19	8	22	3	44	310	212	193	96	20	29.5
100	220	180	156	19	8	24	3	44	350	247	216	116	40	40.5
125	250	210	184	19	8	26	3	44	400	272	239	116	40	58.8
150	285	240	211	23	8	26	3	44	480	297	284	116	40	80.7

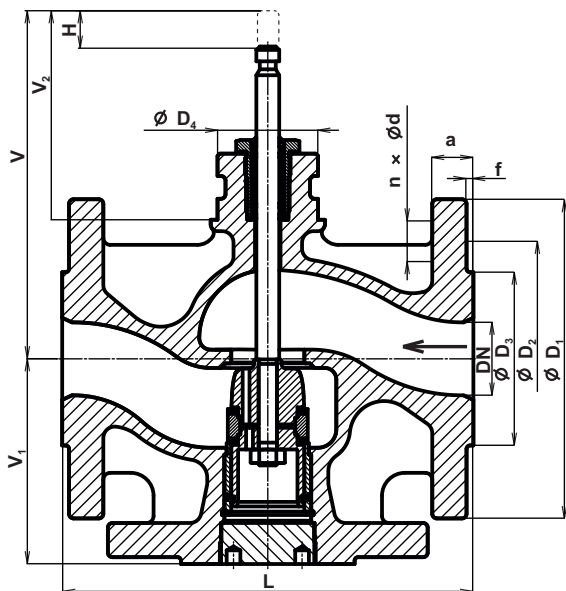

DN 15-40

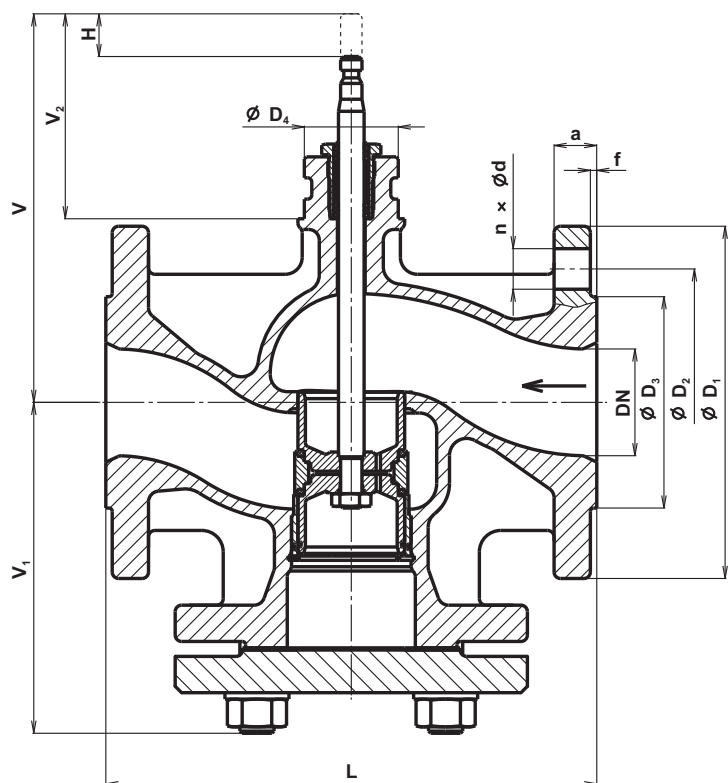

DN 50-150



## RV 113 M



**Three-way control valves**  
**DN 15 - 150, PN 16**  
**DN 15 - 40, PN 6**

### Description

Control valves RV 113 M are flanged, 3-way valves with mixing or diverting function with high tightness in both ports designed for regulation. Owing to unique flow characteristic LDMspline<sup>®</sup>, optimized for regulation of thermodynamic processes, the valves are ideal for applications in heating and air-conditioning. Flow characteristics, Kvs values and leakage rates correspond to international standards.

The valves type RV 113 M have connection to the following actuators: Siemens, Belimo and Ekorex.

### Application

Control valves RV113 are designed for applications in heating and air-conditioning. Control valves type RV113 are also available in silicone free execution (marking in a specification number SF). The maximum permissible operating pressures are specified below on this page.

### Process media

The valves RV113 are suitable for media such as water, air and other media compatible with material of body and internal parts in range +2 to +150°C.

Sealing surfaces of trim are resistant to common dirt and impurities in medium. However, for abrasive impurities it is recommended to pipe a strainer before the valve to ensure reliable function.

The valve cannot work in cavitation conditions.

### Installation

The valve in mixing function must be piped with the medium flow according to arrows indicated on the valve body (inlet ports A, B and outlet port AB). For diverting function the valve is to be piped vice versa (inlet port AB and outlet ports A, B).

The valve can be piped in any position except when the actuator is under the valve body.

### Technical data

Series	RV 113 M
Type of valve	Three-way control valve
Nominal size range	DN 15 to 150
Nominal pressure	DN 15 - 150, PN 16; DN 15 - 40, PN 6
Body material	Grey cast iron EN-JL 1040
Plug material	Stainless steel 1.4027
Stem material	Stainless steel 1.4305
Seat sealing	EPDM
Packing	EPDM
Operating temperature range	+2 to +150°C
Connection	Flanges type B1 (raised-faced) Acc. to ČSN-EN 1092-2 (4/2002)
Face to face dimensions	Series 1 acc. to ČSN-EN 558 (9/2008)
Type of plug	V-ported with soft seat sealing
Flow characteristic	LDMspline <sup>®</sup> in straight way, linear in angle way
Kvs values	1,6 to 360 m <sup>3</sup> /h
Leakage rate	Class IV. - S1 acc. to ČSN-EN 1349 (5/2001) (<0.0005 % Kvs)
Rangeability r	50 : 1

### Maximum permissible operating pressures [ MPa]

Material	PN	Temperature [°C]										
		120	150	200	250	300	350	400	450	500	525	550
Grey cast iron EN-JL 1040 (EN-GJL-250)	16	1,60	1,44	---	---	---	---	---	---	---	---	---
	6	0,60	0,54	---	---	---	---	---	---	---	---	---



## Kvs values and differential pressures

The value  $\Delta p_{\max}$  is maximum differential pressure when reliable closing and opening is guaranteed.

Because of the seat and plug service life, it is recommended so that permanent differential pressure would not exceed 0.4 MPa.

For further info. on actuating see actuators' catalogue sheets		Actuating (actuator)			Siemens	Belimo				Ekorex			LDM	
DN	H	Linear force			700 N	800 N	1600 N	2000 N	2000 N	3200 N	4000 N	2000 N	2500 N	
		Kvs [m <sup>3</sup> /h]			$\Delta p_{\max}$	$\Delta p_{\max}$	$\Delta p_{\max}$	$\Delta p_{\max}$	$\Delta p_{\max}$	$\Delta p_{\max}$	$\Delta p_{\max}$	$\Delta p_{\max}$	$\Delta p_{\max}$	
		1	2	3	MPa	MPa	MPa	MPa	MPa	MPa	MPa	MPa	MPa	
<b>PN 6</b>														
15	20	4	2.5	1.6	0.60	0.60	0.60	---	0.60	---	---	0.60	0.60	
20		6.3	---	---	0.60	0.60	0.60	---	0.60	---	---	0.60	0.60	
25		10	---	---	0.60	0.60	0.60	---	0.60	---	---	0.60	0.60	
32		16	---	---	0.60	0.60	0.60	---	0.60	---	---	0.60	0.60	
40		25	---	---	0.39	0.46	0.60	---	0.60	---	---	0.60	0.60	
<b>PN 16</b>														
15	20	4	2.5	1.6	1.60	1.60	1.60	---	1.60	---	---	1.60	1.60	
20		6.3	---	---	1.35	1.60	1.60	---	1.60	---	---	1.60	1.60	
25		10	---	---	0.86	1.03	1.60	---	1.60	---	---	1.60	1.60	
32		16	---	---	0.52	0.63	1.48	---	1.60	---	---	1.60	1.60	
40		25	---	---	0.34	0.41	0.96	---	1.24	---	---	1.24	1.58	
50		40.0	---	---	0.17	0.21	0.55	---	0.72	1.23	1.57	0.72	0.94	
65		63.0	---	---	0.10	0.13	0.33	---	0.44	0.75	0.96	0.44	0.57	
80	100.0	---	---	0.06	0.08	0.22	---	0.29	0.50	0.64	0.29	0.38		
100	40	160.0	---	---	---	---	---	0.16	0.16	0.30	0.40	0.16	0.22	
125		250.0	---	---	---	---	---	0.10	0.10	0.19	0.25	0.10	0.14	
150		360.0	---	---	---	---	---	0.07	0.07	0.13	0.18	0.07	0.10	

## Supplied types of actuators

			stroke
Siemens	Electric actuator SQX 32.00 a SQX 32.03	AC 230 V, 3-position control, 700 N	20 mm
	Electric actuator SQX 82.00 a SQX 82.03	AC 24 V, 3-position control, 700 N	
	Electric actuator SQX 62	AC 24 V, control 0...10V, 4...20mA, 700 N	
Belimo	Electric actuator NV24-3	AC/DC 24 V, 3-position control, 800 N	20 mm
	Electric actuator NV230-3	AC 230 V, 3-position control, 800 N	
	Electric actuator NVF24-MFT	AC/DC 24 V, 3-position control, ON-OFF, 0...10V fail-safe function - indirect, 800 N	
	Electric actuator NVF24-MFT-E	AC/DC 24 V, 3-position control, ON-OFF, 0...10V fail-safe function - direct, 800 N	
	Electric actuator NV24-MFT	AC/DC 24 V, 3-position control, 0...10V, 800 N	
	Electric actuator Nvy24-MFT	AC/DC 24 V, 3-position control, 0...10V, 800 N quick running time 35 s,	
	Electric actuator NVG24-MFT	AC/DC 24 V, 3-position control, 0...10V, 1600 N	
	Electric actuator AV24-3	AC/DC 24 V, 3-position control, 2000 N	
Ekorex	Electric actuator AV230-3	AC 230 V, 3-position control, 2000 N	40 mm
	Electric actuator AV24-MFT	AC 24 V, 3-position control, 0...10V, 2000 N	
	Electric actuator AVY24-MFT	AC 230 V, 3-position control, 0...10V, 2000 N quick running time 60 s	
	Electric actuator PTN2-XX.0	AC 230 V, 3-position control, 0...10V, 4...20mA	
	Electric actuator PTN2-XX.2	AC 24 V, 3-position control, 0...10V, 4...20mA	
LDM	Electric actuator ANT40.11	AC/DC 24 V (230 V with modul), 2500 N 3(2)-position control, 0...10V, 4...20mA	20 - 40 mm
	Electric actuator ANT40.11S	AC/DC 24 V (230 V s modulem), 2000 N 3(2)-position control, 0...10V, 4...20mA fail-safe function - indirect	
	Electric actuator ANT40.11R	AC/DC 24 V (230 V s modulem), 2000 N 3(2)-position control, 0...10V, 4...20mA fail-safe function - direct	

## Dimensions and weights for the type RV 113 M

PN 6

DN	D <sub>1</sub> mm	D <sub>2</sub> mm	D <sub>3</sub> mm	d mm	n mm	a mm	f mm	D <sub>4</sub> mm	L mm	V mm	V <sub>1</sub> mm	V <sub>2</sub> mm	H mm	m kg
15	80	55	38	11	4	12	2	44	130	147	65	96	20	2.6
20	90	65	48	11	4	14	2	44	150	147	75	96	20	3.5
25	100	75	58	11	4	14	3	44	160	147	80	96	20	4.1
32	120	90	69	14	4	16	3	44	180	157	90	96	20	6.3
40	130	100	78	14	4	16	3	44	200	167	100	96	20	7.9

PN 16

DN	D <sub>1</sub> mm	D <sub>2</sub> mm	D <sub>3</sub> mm	d mm	n mm	a mm	f mm	D <sub>4</sub> mm	L mm	V mm	V <sub>1</sub> mm	V <sub>2</sub> mm	H mm	m kg
15	95	65	46	14	4	14	2	44	130	147	65	96	20	3.5
20	105	75	56	14	4	16	2	44	150	147	75	96	20	4.6
25	115	85	65	14	4	16	3	44	160	147	80	96	20	5.4
32	140	100	76	19	4	18	3	44	180	157	90	96	20	8.5
40	150	110	84	19	4	18	3	44	200	167	100	96	20	10.5
50	165	125	99	19	4	20	3	44	230	182	115	96	20	13.0
65	185	145	118	19	4	20	3	44	290	192	145	96	20	18.3
80	200	160	132	19	8	22	3	44	310	212	155	96	20	24.1
100	220	180	156	19	8	24	3	44	350	247	175	116	40	33.8
125	250	210	184	19	8	26	3	44	400	272	200	116	40	49.3
150	285	240	211	23	8	26	3	44	480	297	240	116	40	69.3

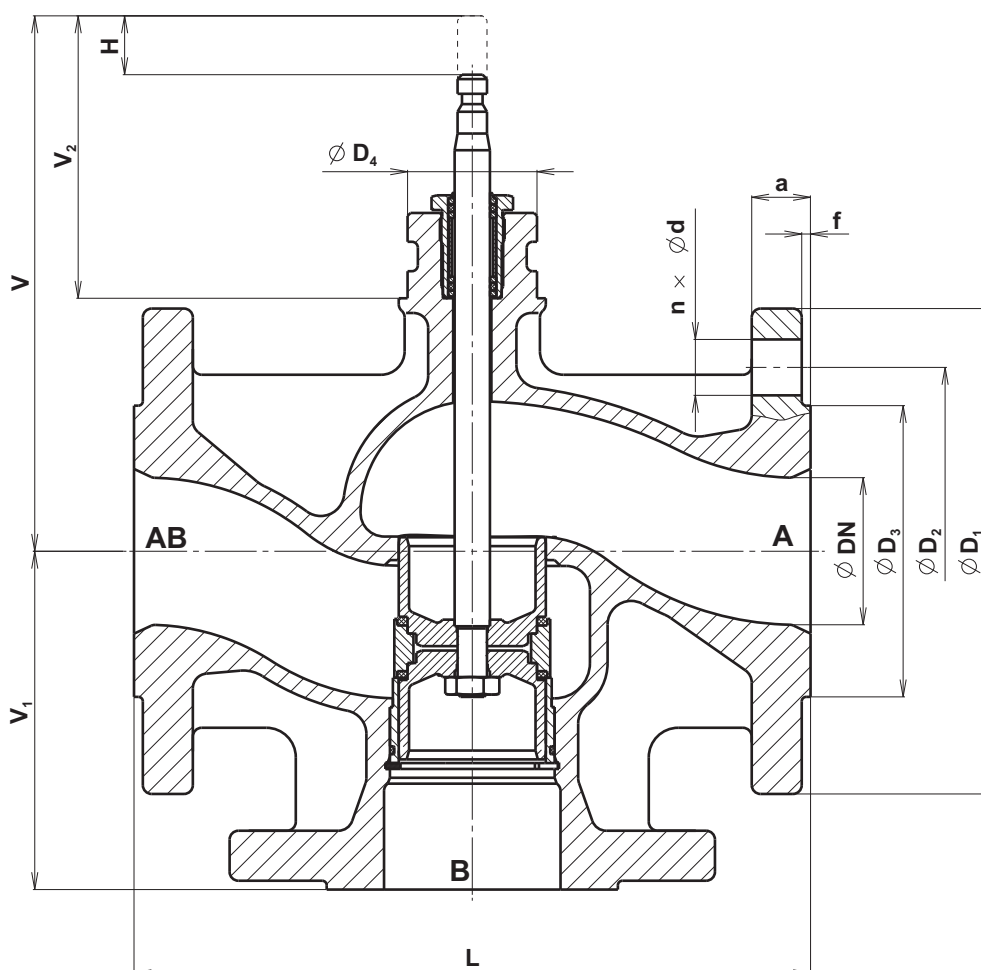

## RV 113 L



**Two-way control valves**  
**DN 15 - 150, PN 16**  
**DN 15 - 40, PN 6**

### Description

Control valves RV 113 L are flanged, 2-way valves with pressure balanced plug (except DN 15 - 25) and high tightness designed for regulation and closing of the medium flow. Its design enables the valve to be applicable at high differential pressures with low-linear-force actuators. Owing to unique flow characteristic LDMspline®, optimized for regulation of thermodynamic processes, the valves are ideal for applications in heating and air-conditioning.

Flow characteristics, Kvs values and leakage rates correspond to international standards.

The valves type RV 113 L have connection to the electrohydraulic actuators Siemens.

### Application

Control valves RV113 are designed for applications in heating and air-conditioning. Control valves type RV113 are also available in silicone free execution (marking in a specification number SF). The maximum permissible operating pressures are specified below on this page.

### Process media

The valves RV113 are suitable for media such as water, air and other media compatible with material of body and internal parts in range +2 to +150°C.

Sealing surfaces of trim are resistant to common dirt and impurities in medium. However, for abrasive impurities it is recommended to pipe a strainer before the valve to ensure reliable function.

The valve cannot work in cavitation conditions.

### Installation

The valve must be piped with the medium flow according to arrows indicated on the valve body.

The valve can be piped in any position except when the actuator is under the valve body.

### Technical data

Series	RV 113 L
Type of valve	Three-way control valve
Nominal size range	DN 15 to 150
Nominal pressure	DN 15 - 150, PN 16; DN 15 - 40, PN 6
Body material	Grey cast iron EN-JL 1040
Plug material	Stainless steel 1.4027 (1.4028)
Stem material	Stainless steel 1.4305
Seat sealing	EPDM
Packing	EPDM
Operating temperature range	+2 to +150°C
Connection	Flanges type B1 (raised-faced) Acc. to ČSN-EN 1092-2 (4/2002)
Face to face dimensions	Series 1 acc. to ČSN-EN 558 (9/2008)
Type of plug	V-ported with soft seat sealing
Flow characteristic	LDMspline®
Kvs values	1,6 to 360 m³/h
Leakage rate	Class IV. - S1 acc. to ČSN-EN 1349 (5/2001) (<0.0005 % Kvs)
Rangeability r	50 : 1

### Maximum permissible operating pressures [MPa]

Material	PN	Temperature [°C]										
		120	150	200	250	300	350	400	450	500	525	550
Grey cast iron EN-JL 1040 (EN-GJL-250)	16	1,60	1,44	---	---	---	---	---	---	---	---	---
	6	0,60	0,54	---	---	---	---	---	---	---	---	---

## Kvs values and differential pressures

The value  $\Delta p_{\max}$  is maximum differential pressure when reliable closing and opening is guaranteed.

Because of the seat and plug service life, it is recommended so that permanent differential pressure would not exceed 0.4 MPa.

For further info. on actuating see actuators' catalogue sheets		Actuating (actuator)			Siemens		
					SKD	SKB	SKC
		Linear force			1000 N	2800 N	2800 N
DN	H	Kvs [m <sup>3</sup> /h]			$\Delta p_{\max}$	$\Delta p_{\max}$	$\Delta p_{\max}$
		1	2	3	MPa	MPa	MPa
<b>PN 6</b>							
15	20	4	2.5	1.6	0.60	---	---
20		6.3	---	---	0.60	---	---
25		10	---	---	0.60	0.60	---
32		16	---	---	0.60	0.60	---
40		25	---	---	0.60	0.60	---
<b>PN 16</b>							
15	20	4	2.5	1.6	1.60	---	---
20		6.3	---	---	1.60	---	---
25		10	---	---	1.37	1.60	---
32		16	---	---	1.60	1.60	---
40		25	---	---	1.60	1.60	---
50		40.0	---	---	1.60	1.60	---
65		63.0	---	---	1.60	1.60	---
80	100.0	---	---	1.60	1.60	---	
100	40	160.0	---	---	---	---	1.60
125		250.0	---	---	---	---	1.60
150		360.0	---	---	---	---	1.60

## Supplied types of actuators

			stroke
Siemens	Electric actuator SKD 32.50	AC 230 V, 3-position control, 120 s	20 mm
	Electric actuator SKD 82.50	AC 24 V, 3-position control, 120 s	
	Electric actuator SKD 32.51	AC 230 V, 3-position control, 120 s, fail-safe fct.	
	Electric actuator SKD 32.21	AC 230 V, 3-position control, 30 s, fail-safe funct.	
	Electric actuator SKD 82.51	AC 24 V, 3-position control, fail-safe function	
	Electric actuator SKD 60	AC 24 V, control 0...10 V, 4...20 mA	
	Electric actuator SKD 62	AC 24 V, control 0...10 V, 4...20 mA, fail-safe fct.	
	Electric actuator SKD 62UA	AC 24 V, control 0...10 V, 4...20 mA, fail-safe fct.	
Siemens	Electric actuator SKB 32.50	AC 230 V, 3-position control, 120 s	20 mm
	Electric actuator SKB 82.50	AC 24 V, 3-position control, 120 s	
	Electric actuator SKB 32.51	AC 230 V, 3-position control, 120 s, fail-safe fct.	
	Electric actuator SKB 82.51	AC 24 V, 3-position control, 120 s, fail-safe fct.	
	Electric actuator SKB 60	AC 24 V, control 0...10 V, 4...20 mA	
	Electric actuator SKB 62	AC 24 V, control 0...10 V, 4...20 mA, fail-safe fct.	
		Electric actuator SKB 62UA	
Siemens	Electric actuator SKC 32.50	AC 230 V, 3-position control, 120 s	40 mm
	Electric actuator SKC 82.50	AC 24 V, 3-position control, 120 s	
	Electric actuator SKC 32.51	AC 230 V, 3-position control, 120 s, fail-safe fct.	
	Electric actuator SKC 82.51	AC 24 V, 3-position control, 120 s, fail-safe fct.	
	Electric actuator SKC 60	AC 24 V, control 0...10 V, 4...20 mA	
	Electric actuator SKC 62	AC 24 V, control 0...10 V, 4...20 mA, fail-safe fct.	
		Electric actuator SKC 62UA	

## Dimensions and weights for the type RV 113 L

PN 6														
DN	D <sub>1</sub>	D <sub>2</sub>	D <sub>3</sub>	d	n	a	f	D <sub>4</sub>	L	V	V <sub>1</sub>	V <sub>2</sub>	H	m
	mm	mm	mm	mm	mm	mm	mm	mm	mm	mm	mm	mm	mm	kg
15	80	55	38	11	4	12	2	44	130	147	65	96	20	2.6
20	90	65	48	11	4	14	2	44	150	147	75	96	20	3.5
25	100	75	58	11	4	14	3	44	160	147	80	96	20	4.1
32	120	90	69	14	4	16	3	44	180	157	90	96	20	6.3
40	130	100	78	14	4	16	3	44	200	167	100	96	20	7.9

PN 16														
DN	D <sub>1</sub>	D <sub>2</sub>	D <sub>3</sub>	d	n	a	f	D <sub>4</sub>	L	V	V <sub>1</sub>	V <sub>2</sub>	H	m
	mm	mm	mm	mm	mm	mm	mm	mm	mm	mm	mm	mm	mm	kg
15	95	65	46	14	4	14	2	44	130	147	65	96	20	3.5
20	105	75	56	14	4	16	2	44	150	147	75	96	20	4.6
25	115	85	65	14	4	16	3	44	160	147	80	96	20	5.4
32	140	100	76	19	4	18	3	44	180	157	90	96	20	8.5
40	150	110	84	19	4	18	3	44	200	167	100	96	20	10.5
50	165	125	99	19	4	20	3	44	230	182	155	96	20	16.7
65	185	145	118	19	4	20	3	44	290	192	185	96	20	23.0
80	200	160	132	19	8	22	3	44	310	212	193	96	20	29.5
100	220	180	156	19	8	24	3	44	350	247	216	116	40	40.5
125	250	210	184	19	8	26	3	44	400	272	239	116	40	58.8
150	285	240	211	23	8	26	3	44	480	297	284	116	40	80.7

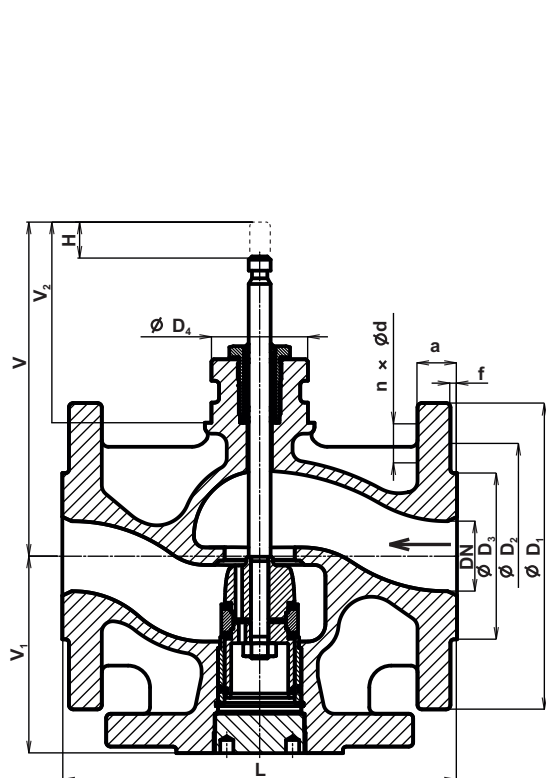

DN 15-40

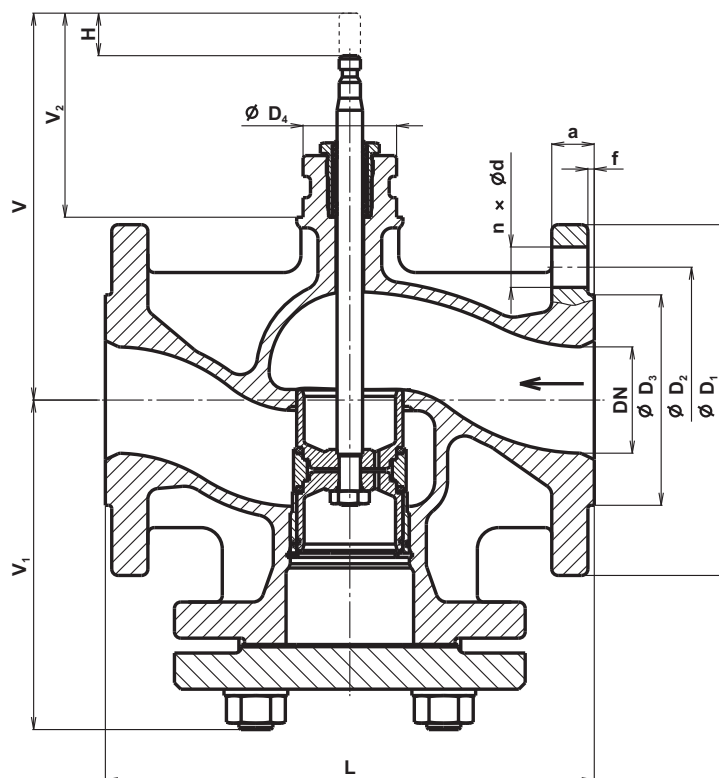

DN 50-150

## RV 113 S



**Three-way control valves**  
**DN 15 - 150, PN 16**  
**DN 15 - 40, PN 6**

### Description

Control valves RV 113 S are flanged, 3-way valves with mixing or diverting function with high tightness in a straight way designed for regulation. Owing to unique flow characteristic LDMspline®, optimized for regulation of thermodynamic processes, the valves are ideal for applications in heating and air-conditioning.

Flow characteristics, Kvs values and leakage rates correspond to international standards.

The valves type RV 113 S have connection to the Siemens electrohydraulic actuators.

### Application

Control valves RV113 are designed for applications in heating and air-conditioning. Control valves type RV113 are also available in silicone free execution (marking in a specification number SF). The maximum permissible operating pressures are specified below on this page.

### Process media

The valves RV113 are suitable for media such as water, air and other media compatible with material of body and internal parts in range +2 to +150°C.

Sealing surfaces of trim are resistant to common dirt and impurities in medium. However, for abrasive impurities it is recommended to pipe a strainer before the valve to ensure reliable function.

The valve cannot work in cavitation conditions.

### Installation

The valve in mixing function must be piped with the medium flow according to arrows indicated on the valve body (inlet ports A, B and outlet port AB). For diverting function the valve is to be piped vice versa (inlet port AB and outlet ports A, B).

The valve can be piped in any position except when the actuator is under the valve body.

### Technical data

Series	RV 113 S
Type of valve	Three-way control valve
Nominal size range	DN 15 to 150
Nominal pressure	DN 15 - 150, PN 16; DN 15 - 40, PN 6
Body material	Grey cast iron EN-JL 1040
Plug material	Stainless steel 1.4027
Stem material	Stainless steel 1.4305
Seat sealing	EPDM
Packing	EPDM
Operating temperature range	+2 to +150°C
Connection	Flanges type B1 (raised-faced) Acc. to ČSN-EN 1092-2 (4/2002)
Face to face dimensions	Series 1 acc. to ČSN-EN 558 (9/2008)
Type of plug	V-ported with soft seat sealing
Flow characteristic	LDMspline® in straight way, linear in angle way
Kvs values	1,6 to 360 m <sup>3</sup> /h
Leakage rate in direct way	Class IV. - S1 acc. to ČSN-EN 1349 (5/2001) (<0.0005 % Kvs)
Leakage rate in angle way	Not guaranteed (<2% Kvs)
Rangeability r	50 : 1

### Maximum permissible operating pressures [ MPa]

Material	PN	Temperature [°C]										
		120	150	200	250	300	350	400	450	500	525	550
Grey cast iron EN-JL 1040 (EN-GJL-250)	16	1,60	1,44	---	---	---	---	---	---	---	---	---
	6	0,60	0,54	---	---	---	---	---	---	---	---	---

## Kvs values and differential pressures

The value  $\Delta p_{\max}$  is maximum differential pressure when reliable closing and opening is guaranteed.

Because of the seat and plug service life, it is recommended so that permanent differential pressure would not exceed 0.4 MPa.

For further info. on actuating see actuators' catalogue sheets		Actuating (actuator)			Siemens		
					SKD	SKB	SKC
		Linear force			1000 N	2800 N	2800 N
DN	H	Kvs [m <sup>3</sup> /h]			$\Delta p_{\max}$	$\Delta p_{\max}$	$\Delta p_{\max}$
		1	2	3	MPa	MPa	MPa
<b>PN 6</b>							
15	20	4	2.5	1.6	0.60	---	---
20		6.3	---	---	0.60	---	---
25		10	---	---	0.60	0.60	---
32		16	---	---	0.60	0.60	---
40		25	---	---	0.60	0.60	---
<b>PN 16</b>							
15	20	4	2.5	1.6	1.60	---	---
20		6.3	---	---	1.60	---	---
25		10	---	---	1.37	1.60	---
32		16	---	---	1.60	1.60	---
40		25	---	---	1.60	1.60	---
50		40.0	---	---	1.60	1.60	---
65		63.0	---	---	1.60	1.60	---
80	100.0	---	---	1.60	1.60	---	
100	40	160.0	---	---	---	---	1.60
125		250.0	---	---	---	---	1.60
150		360.0	---	---	---	---	1.60

## Supplied types of actuators

			stroke
Siemens	Electric actuator SKD 32.50	AC 230 V, 3-position control, 120 s	20 mm
	Electric actuator SKD 82.50	AC 24 V, 3-position control, 120 s	
	Electric actuator SKD 32.51	AC 230 V, 3-position control, 120 s, fail-safe fct.	
	Electric actuator SKD 32.21	AC 230 V, 3-position control, 30 s, fail-safe funct.	
	Electric actuator SKD 82.51	AC 24 V, 3-position control, fail-safe function	
	Electric actuator SKD 60	AC 24 V, control 0...10 V, 4...20 mA	
	Electric actuator SKD 62	AC 24 V, control 0...10 V, 4...20 mA, fail-safe fct.	
	Electric actuator SKD 62UA	AC 24 V, control 0...10 V, 4...20 mA, fail-safe fct.	
Siemens	Electric actuator SKB 32.50	AC 230 V, 3-position control, 120 s	20 mm
	Electric actuator SKB 82.50	AC 24 V, 3-position control, 120 s	
	Electric actuator SKB 32.51	AC 230 V, 3-position control, 120 s, fail-safe fct.	
	Electric actuator SKB 82.51	AC 24 V, 3-position control, 120 s, fail-safe fct.	
	Electric actuator SKB 60	AC 24 V, control 0...10 V, 4...20 mA	
	Electric actuator SKB 62	AC 24 V, control 0...10 V, 4...20 mA, fail-safe fct.	
		Electric actuator SKB 62UA	
Siemens	Electric actuator SKC 32.50	AC 230 V, 3-position control, 120 s	40 mm
	Electric actuator SKC 82.50	AC 24 V, 3-position control, 120 s	
	Electric actuator SKC 32.51	AC 230 V, 3-position control, 120 s, fail-safe fct.	
	Electric actuator SKC 82.51	AC 24 V, 3-position control, 120 s, fail-safe fct.	
	Electric actuator SKC 60	AC 24 V, control 0...10 V, 4...20 mA	
	Electric actuator SKC 62	AC 24 V, control 0...10 V, 4...20 mA, fail-safe fct.	
		Electric actuator SKC 62UA	



## Dimensions and weights for the type RV 113 S

PN 6

DN	D <sub>1</sub>	D <sub>2</sub>	D <sub>3</sub>	d	n	a	f	D <sub>4</sub>	L	V	V <sub>1</sub>	V <sub>2</sub>	H	m
	mm	mm	mm	mm	mm	mm	mm	mm	mm	mm	mm	mm	mm	kg
15	80	55	38	11	4	12	2	44	130	147	65	96	20	2.6
20	90	65	48	11	4	14	2	44	150	147	75	96	20	3.5
25	100	75	58	11	4	14	3	44	160	147	80	96	20	4.1
32	120	90	69	14	4	16	3	44	180	157	90	96	20	6.3
40	130	100	78	14	4	16	3	44	200	167	100	96	20	7.9

PN 16

DN	D <sub>1</sub>	D <sub>2</sub>	D <sub>3</sub>	d	n	a	f	D <sub>4</sub>	L	V	V <sub>1</sub>	V <sub>2</sub>	H	m
	mm	mm	mm	mm	mm	mm	mm	mm	mm	mm	mm	mm	mm	kg
15	95	65	46	14	4	14	2	44	130	147	65	96	20	3.5
20	105	75	56	14	4	16	2	44	150	147	75	96	20	4.6
25	115	85	65	14	4	16	3	44	160	147	80	96	20	5.4
32	140	100	76	19	4	18	3	44	180	157	90	96	20	8.5
40	150	110	84	19	4	18	3	44	200	167	100	96	20	10.5
50	165	125	99	19	4	20	3	44	230	182	115	96	20	13.0
65	185	145	118	19	4	20	3	44	290	192	145	96	20	18.3
80	200	160	132	19	8	22	3	44	310	212	155	96	20	24.1
100	220	180	156	19	8	24	3	44	350	247	175	116	40	33.8
125	250	210	184	19	8	26	3	44	400	272	200	116	40	49.3
150	285	240	211	23	8	26	3	44	480	297	240	116	40	69.3

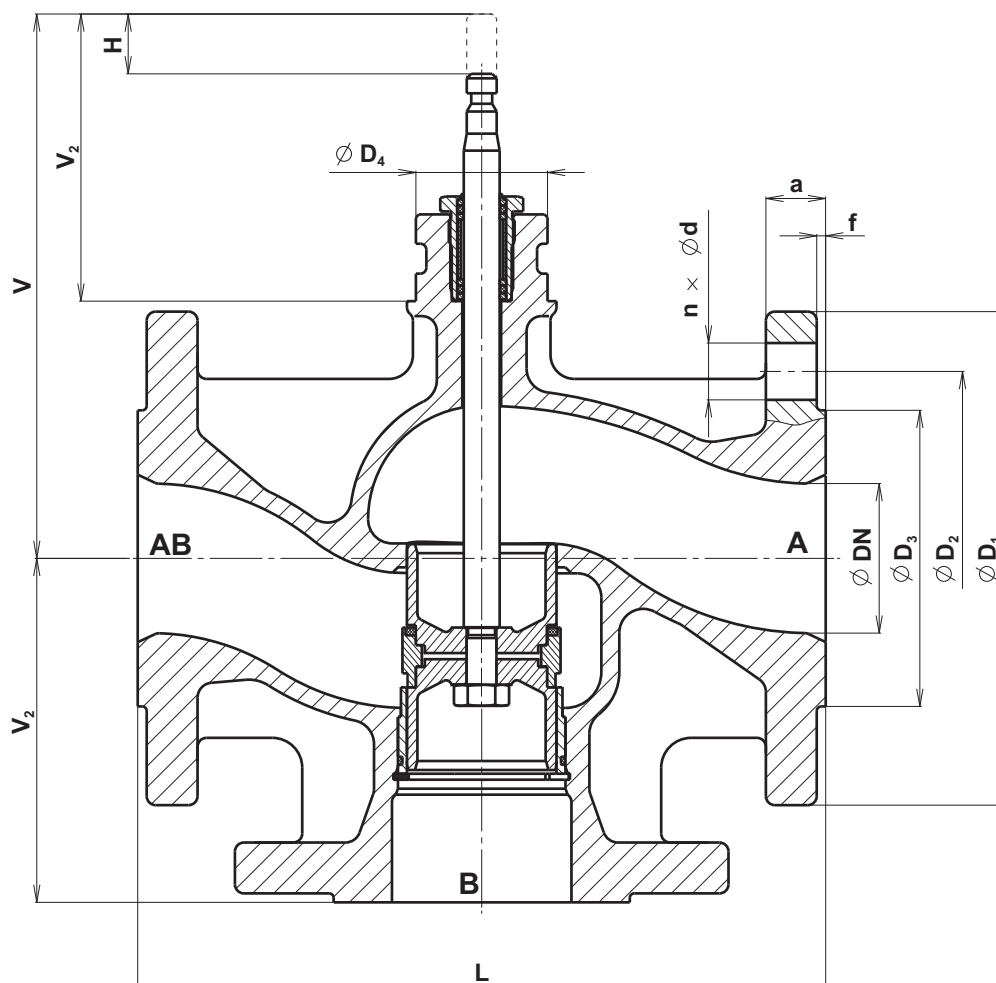

## The valve complete specification No. for ordering RV 113

		XX	XXX	X	XXXX	XX	/	XXX	-	XXX
1. Valve	Control valve	RV								
2. Series	Valves made of grey cast iron		113							
3. Type of valve	Two-way control valve			R						
	Three-way control valve			M						
	Two-way control valve for electrohydraulic actuators			L						
	Three-way control valve for electrohydraulic actuators			S						
4. Execution	Flanged, two-way				4					
	Flanged, three-way mixing (diverting)				6					
5. Body material	Grey cast iron				3					
6. Flow characteristic	LDMspline® / linear				3					
7. Kvs	Column No. acc. to Kvs value table				X					
8. Nominal pressure PN	PN 6					06				
	PN 16					16				
9. Max. temperature °C	150°C							150		
10. Nominal size DN	DN 15 to 150									XXX
11. Execution	Normal									
	Silicone free									SF

**Ordering example: RV113 R 4331 16/150-065**

The actuator must be specified separately.



## Electric actuators SQX 32..., SQX 82... Siemens (Landis & Staefa)

### Technical data

Type	SQX 32.00	SQX 32.03	SQX 82.00	SQX 82.03
Voltage	230 V		24 V	
Frequency	50...60 Hz			
Power consumption	3 VA	6,5 VA	3 VA	6,5 VA
Control	3 - position control			
Open-close running time	150 s	35 s	150 s	35 s
Nominal force	700 N			
Travel	20 mm			
Enclosure	IP 54			
Process medium max. t.	140°C			
Ambient temp. range	-15 to 50°C			
Ambient humidity limit	5 to 95 %			
Weight	1,5 kg			

### Accessories

1 potentiometer and 1 auxiliary switch ASZ7.4      0...1000 Ω

1 pair of auxiliary switches ASC9.4

1 auxiliary switch ASC9.5

*Note : 1 piece of accessory can be installed in actuator only. With nominal stroke of actuator of 20 mm, the real range of potentiometer can be lower by even 25 %.*

### Dimensions of actuator

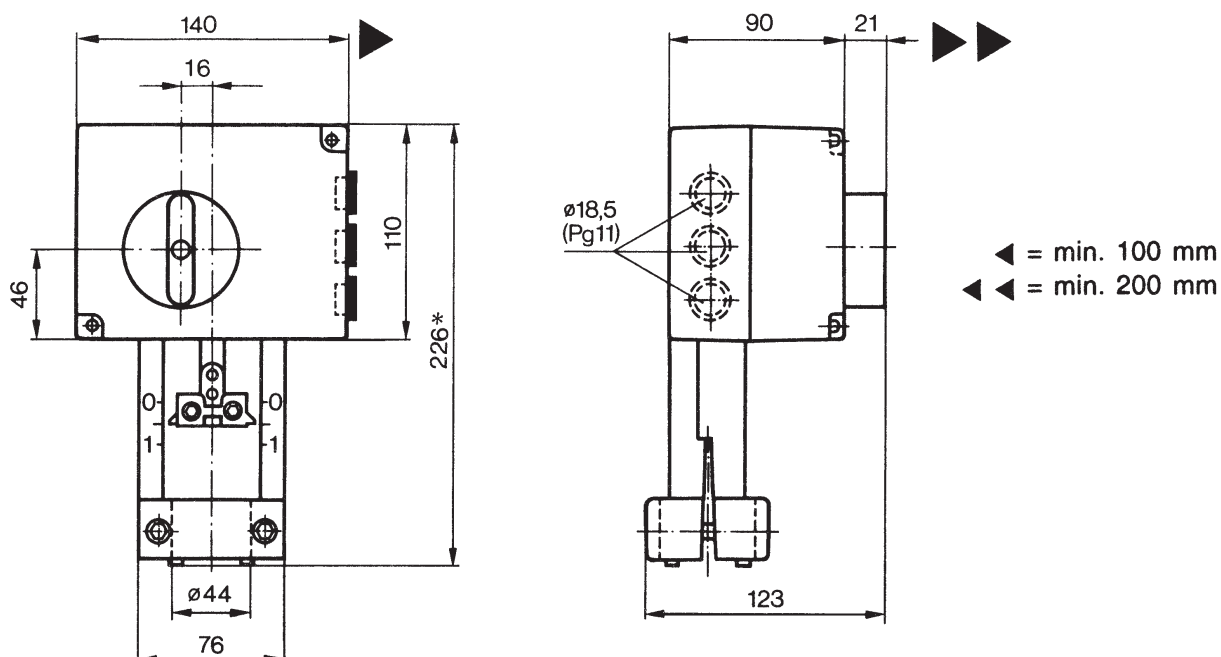

## Wiring diagrams of actuators

SQX 32...

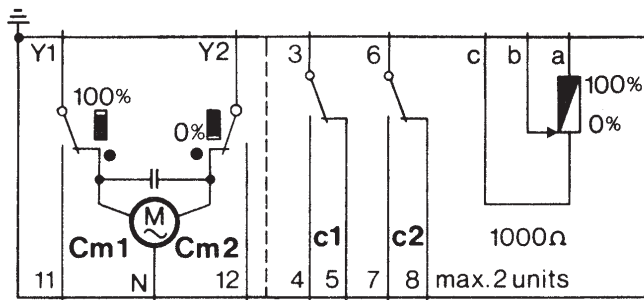

SQX 82...

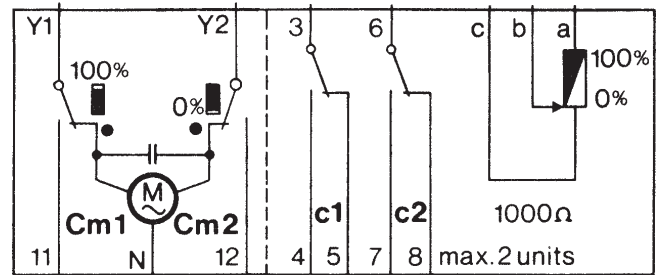

- Cm1            end switch
- Cm2            end switch
- c1              auxiliary switch ASC9.5
- c1,c2          pair of auxiliary switches ASC9.4
- c1,1000 Ω    auxiliary switch and potentiometer  
as a set ASZ7.4

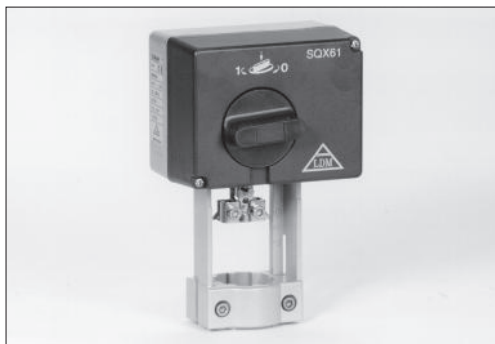

**Electric actuators  
SQX 62  
Siemens (Landis & Staefa)**

**Technical data**

Type	SQX 62
Voltage	24 V
Frequency	50...60 Hz
Power consumption	6,5 VA
Control	0...10 V; 4 - 20 mA
Open-close running time	35 s
Nominal force	700 N
Travel	20 mm
Enclosure	IP 54
Process medium max. temperature	140°C
Ambient temp. range	-15 to 50°C
Ambient humidity limit	0 to 95 % of relative humidity
Weight	1,6 kg

**Dimensions of actuator**

SQX 62

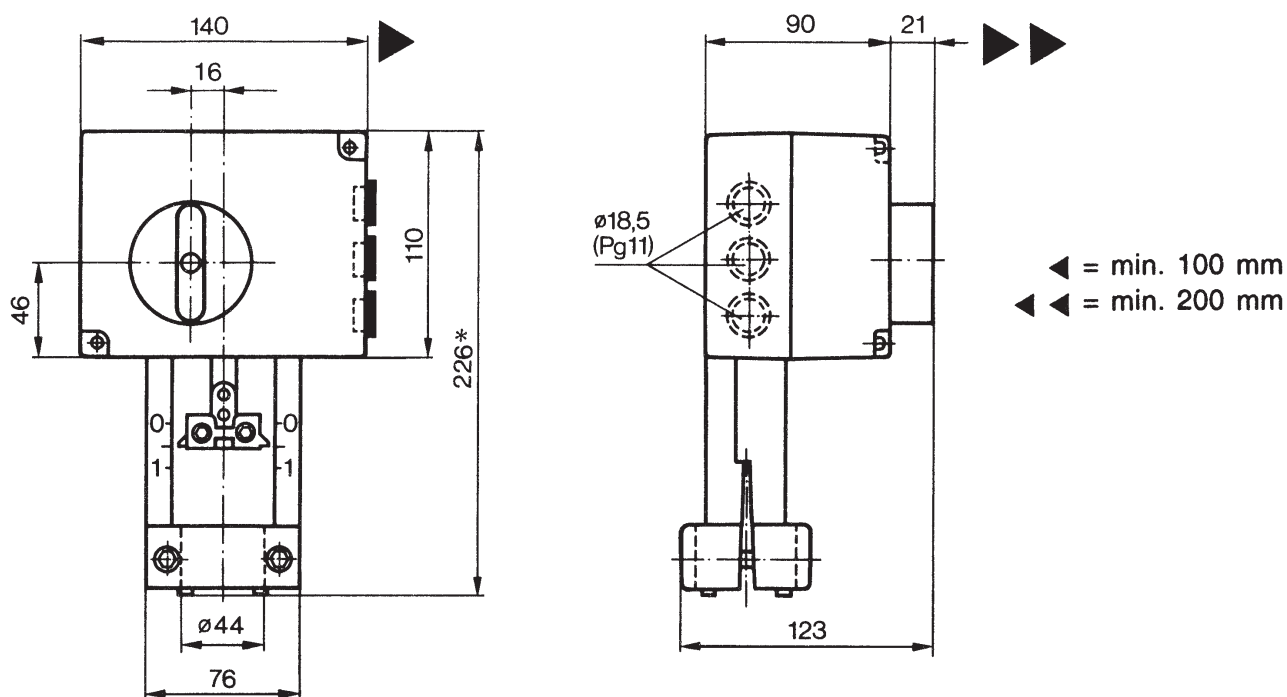

## Wiring diagram of actuator SQX 62

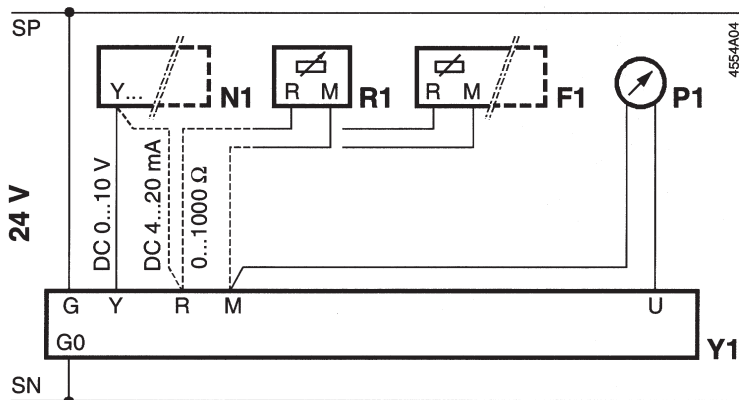

- Y1 actuator SQX62...
- N1 positioner
- F1 anti-frost thermostat with feedback of 0...1000Ω (switch DIL No.2 switched to "1000Ω" position)
- P1 position indicator
- R1 position transmitter with feedback of 0...1000Ω (switch DIL No.2 switched to "1000Ω" position)

Terminal on terminal board

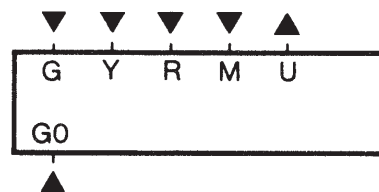

- G, G0 AC 24 V feeding voltage
- G - system potential (SP)
- G0 - system neutral (SN)
- Y control input signal DC 0...10 V
- R control input signal DC 4...20 mA or 0...1000 Ω (type of signal is selected by switch DIL No.2)
- M measuring neutral
- U feedback DC 0...10 V if there is DC 0...10 V or R = 0...1000Ω on Y terminal (maximum availability from both signals), or feedback DC 4...20 mA if there is DC 4...20 mA on R terminal



**HLA**  
**HLB**

**Electrohydraulic actuators**  
**SKD 32..., SKD 82...**  
**Siemens (Landis & Staefa)**

**Technical data**

Type	SKD 32.50	SKD 82.50	SKD 32.51	SKD 32.21	SKD 82.51
Mark in valve spec. No.	HLA		HLB		
Voltage	230 V	24 V	230 V		24 V
Frequency	50...60 Hz				
Power consumption	10 VA		15 VA		
Control	3 - position		3 - position		
Running time open	120 s		120 s	30 s	120 s
Running time closed	120 s		120 s	10 s	120 s
Fail-safe action time	---		8 s		
Nominal force	1000 N				
Travel	20 mm				
Enclosure	IP 54				
Process medium max. t.	140°C (180°C when bellows or cooler is used)				
Ambient and actuator's surface temp. limit	-15 to 50°C				
Ambient humidity limit	5 - 95 % of relative humidity				
Weight	3,6 kg				

**Accessories**

Pair of auxiliary switches ASC9.3

Potentiometer 1000 Ω ASZ7.3 \*)

Potentiometer 135 Ω ASZ7.31 \*)

Potentiometer 200 Ω ASZ7.32 \*)

\*) 1 potentiometer can be used for 1 actuator only

**Dimensions of actuator**

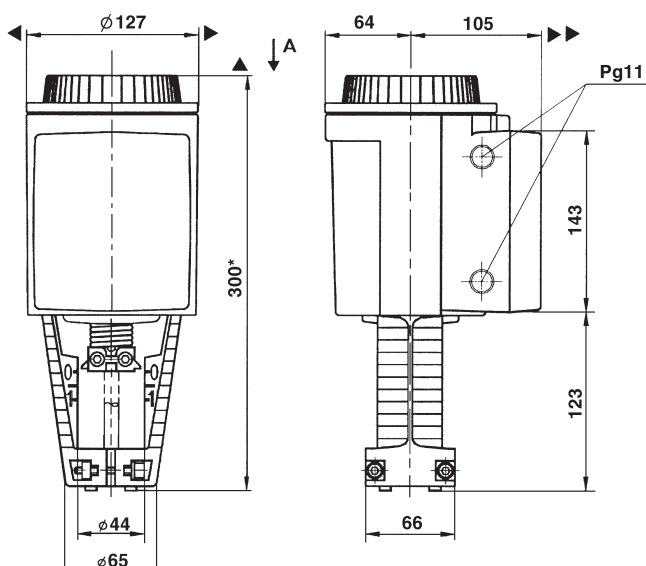



## Wiring diagram of actuator SKD 32...

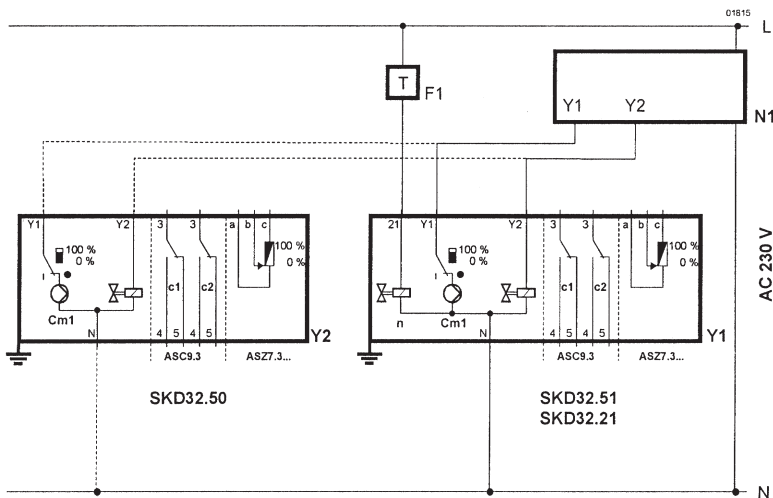

- F1 safety thermostat
- N1 regulator
- Y1/2 actuators
- C1/2 switches
- Cm1 end switch
- ASC9.3 double auxiliary switch
- ASZ7.3... potentiometer
- L phaseGsystem potential (SP)
- G0 system neutral (SN)
- N zero
- Y1 opening of control valve
- Y2 closing of control valve
- 21 fail-safe function

## Wiring diagram of actuator SKD 82...

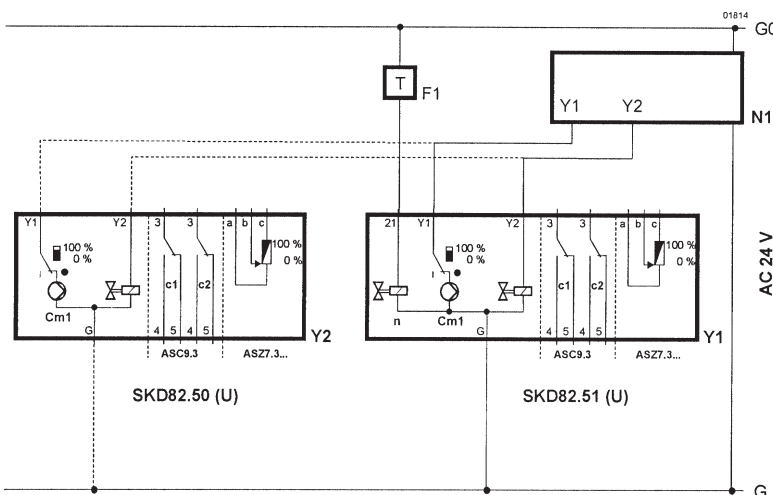

- F1 safety thermostat
- N1 regulator
- Y1/2 actuators
- C1/2 switches
- Cm1 end switch
- ASC9.3 double auxiliary switch
- ASZ7.3... potentiometer
- G system potential (SP)
- G0 system neutral (SN)
- N zero
- Y1 opening of control valve
- Y2 closing of control valve
- 21 fail-safe function



**HLA**  
**HLC**

**Electrohydraulic actuators  
SKD 60 and SKD 62...  
Siemens (Landis & Staefa)**

**Technical data**

Type	SKD 60	SKD 62	SKD 62UA <sup>*)</sup>
Mark in valve spec. No.	HLA	HLC	
Voltage	24 V		
Frequency	50...60 Hz		
Power consumption	17 VA / 12 VA		
Control	0 - 10 V, 4 - 20 mA, 0 - 1000Ω		
Running time open	30 s		
closed	15 s		
Fail-safe action time	---	15 s	
Nominal force	1000 N		
Travel	20 mm		
Enclosure	IP 54		
Process medium max. t.	140°C (180°C when bellows or cooler is used)		
	-15 to 50°C		
Weight	3,6 kg	3,85 kg	3,6 kg

\*) UA... version with improved electronics

**Accessories**

Auxiliary switch 24 V ASC1.6

**Description**

Each actuator with continuous control signal is equipped with ACT control technology enabling the following features as standard:

- stroke range calibration
- state indication via LED
- flow characteristic selection (log / lin)
- selection of control signal at Y terminal
- feedback signal at U terminal corresponding to control signal at Y terminal
- forced control at Z terminal

Version with improved electronics (UA) further enables:

- inversion of control signal
- sequence control
- stroke limiting

**Dimensions of actuator**

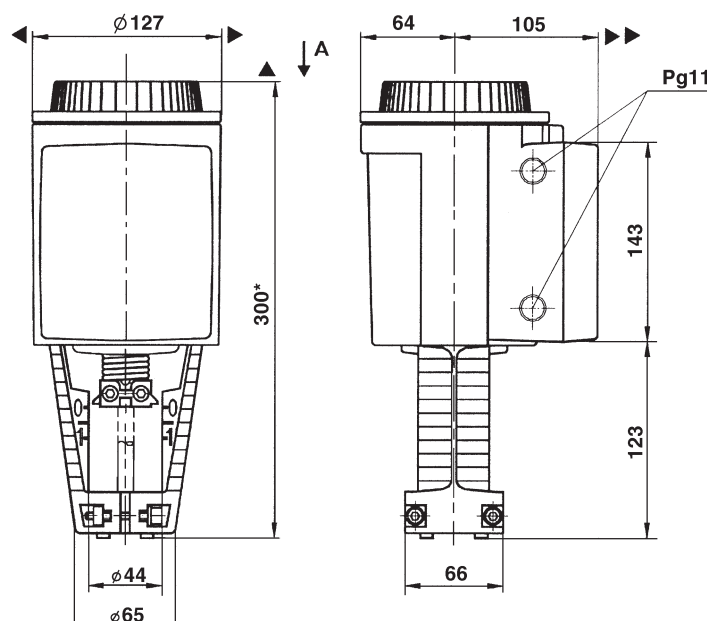

## Wiring diagram of actuators

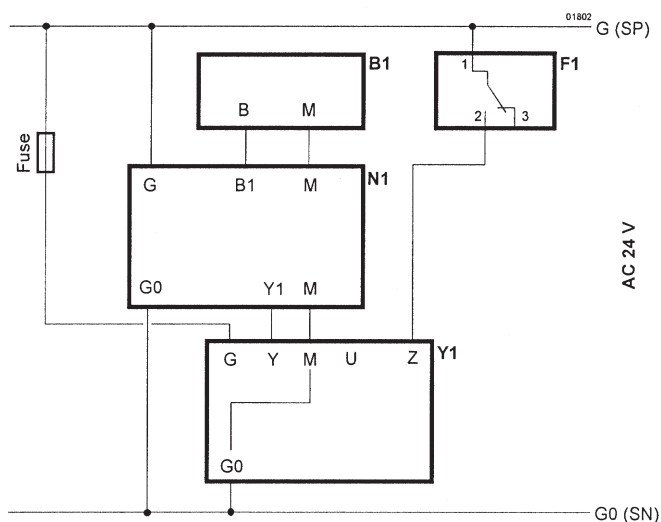

B1 sensor  
 F1 safety thermostat  
 N1 regulator  
 Y1 actuator

### Connection terminals

G0	Voltage AC 24 V: System neutral (SN)
G	Voltage AC 24 V: System potential (SP)
Y	Control input DC 0...10 (30) V or DC 4...20 mA
M	Measuring neutral (=G0)
U	Output for measuring voltage DC 0...10 V or DC 4...20 mA
Z	Input for forced control

### Auxiliary contact ASC1.6

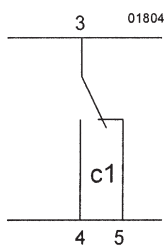

# HLD, HLE HLG, HLH



**Electrohydraulic actuators**  
**SKB 32..., SKB 82...**  
**SKC 32..., SKC 82...**  
**Siemens (Landis & Staefa)**

## Technical data

Type	SKB 32.50	SKB 82.50	SKB 32.51	SKB 82.51	SKC 32.60	SKC 82.60	SKC 32.61	SKC 82.61
Mark in valve spec. No.	HLD		HLE		HLG		HLH	
Voltage	230 V	24 V	230 V	24 V	230 V	24 V	230 V	24 V
Frequency	50...60 Hz							
Power consumption	10 VA		15 VA		19 VA		24 VA	
Control	3 - position							
Running time open	120 s		120 s		120 s		120 s	
Running time closed	120 s		120 s		120 s		120 s	
Fail-safe action time	---		10 s		---		18 s	
Nominal force	2800 N							
Travel	20 mm				40 mm			
Enclosure	IP 54							
Process medium max.t.	220°C (higher temperature with Bellows only)							
Ambient and actuator's surface temperature range	-15 to 50°C							
Ambient humidity range	0 - 95 % relative humidity							
Weight	8,4 kg		8,9 kg		10 kg		10,5 kg	

## Accessories

Pair of auxiliary switches ASC9.3

Potentiometer 1000 Ω ASZ7.3 \*)

Potentiometer 135 Ω ASZ7.31 \*)

Potentiometer 200 Ω ASZ7.32 \*)

\*) 1 potentiometer can be used for 1 actuator only

## Dimensions of actuator

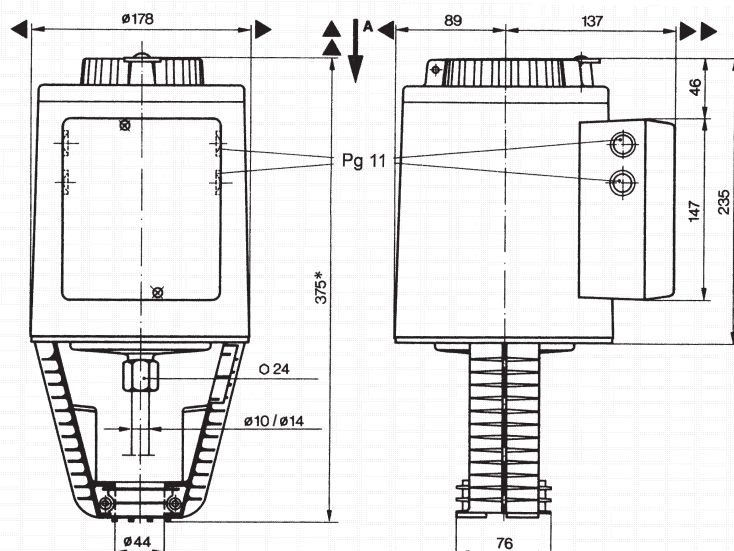

## Wiring diagram of actuators SKB 32..., SKC 32...

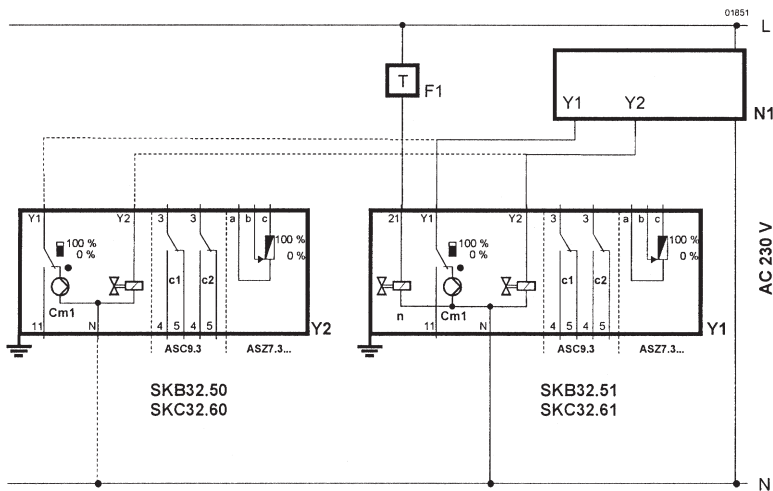

- F1 safety thermostat
- N1 regulator
- Y1/2 actuators
- C1/2 switches
- Cm1 end switch
- ASC9.3 double auxiliary switch
- ASZ7.3... potentiometer
- L phaseGsystem potential (SP)
- G0 system neutral (SN)
- N zero
- Y1 opening of control valve
- Y2 closing of control valve
- 11 control signal of sequence
- 21 fail-safe function

## Wiring diagram of actuators SKB 82..., SKC 82...

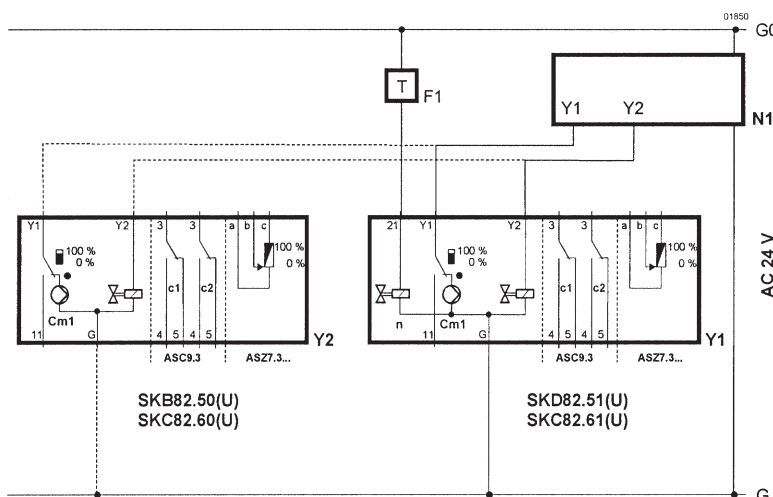

- F1 safety thermostat
- N1 regulator
- Y1/2 actuators
- C1/2 switches
- Cm1 end switch
- ASC9.3 double auxiliary switch
- ASZ7.3... potentiometer
- G system potential (SP)
- G0 system neutral (SN)
- N zero
- Y1 opening of control valve
- Y2 closing of control valve
- 11 control signal of sequence
- 21 fail-safe function

# HLD, HLF HLG, HLI



**Electrohydraulic actuators  
SKB 60 and SKB 62...  
SKC 60 and SKC 62...  
Siemens (Landis & Staefa)**

## Technical data

Type	SKB 60	SKB 62	SKB 62UA <sup>*)</sup>	SKC 60	SKC 62	SKC 62UA <sup>*)</sup>
Mark in valve spec. No.	HLD	HLF		HLG	HLI	
Voltage	24 V					
Frequency	50...60 Hz					
Power consumption	13 VA	17 VA		24 VA	28 VA	
Control	0 - 10 V, 4 - 20 mA, 0 - 1000Ω					
Running time open	120 s			120 s		
closed	15 s			20 s		
Fail-safe action time	---	15 s		---	20 s	
Nominal force	2800 N					
Travel	20 mm			40 mm		
Enclosure	IP 54					
Process medium max.t.	220°C (higher temperature with Bellows only)					
Ambient and actuator's surface temperature range	-15 to 55°C					
Ambient humidity range	0 - 95 % relative humidity					
Weight	8,6 kg			10 kg		

<sup>\*)</sup> UA ... version with improved electronics

## Accessories

Auxiliary switch 24 V ASC1.6

## Description

Each actuator with continuous control signal is equipped with ACT control technology enabling the following features as standard:

- stroke range calibration
- state indication via LED
- flow characteristic selection (log / lin)
- selection of control signal at Y terminal
- feedback signal at U terminal corresponding to control signal at Y terminal
- forced control at Z terminal

Version with improved electronics (UA) further enables:

- inversion of control signal
- sequence control
- stroke limiting

## Dimensions of actuator

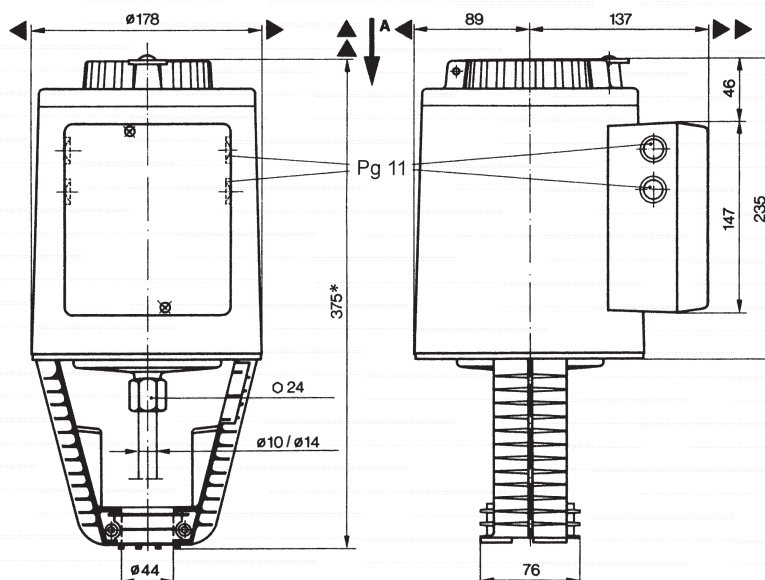

## Wiring diagram of actuators

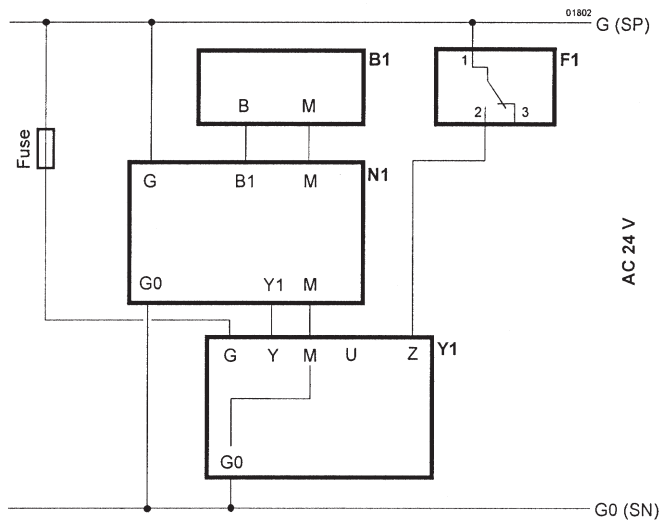

B1 sensor  
 F1 safety thermostat  
 N1 regulator  
 Y1 actuator

### Connection terminals

G0	Voltage AC 24 V: System neutral (SN)
G	Voltage AC 24 V: System potential (SP)
Y	Control input DC 0...10 (30) V or DC 4...20 mA
M	Measuring neutral (=G0)
U	Output for measuring voltage DC 0...10 V or DC 4...20 mA
Z	Input for forced control

### Auxiliary contact ASC1.6

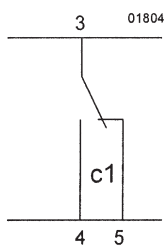





## Electric actuators NV... Belimo

### Technical data

Type	NV24-3	NV230-3	NV24-MFT	NVY24-MFT	NVF24-MFT	NVF24-MFT-E	NVG24-MFT
Voltage	AC/DC 24 V	AC 230 V	AC/DC 24 V				
Frequency	50...60 Hz						
Motor power / Sizing	3 W / 5 VA	6 W / 7 VA	3 W / 5 VA	3 W / 5 VA	5,5 W / 10 VA		3 W / 5 VA
Control	3 - position control		0 - 10 V (3 - position control, ON - OFF)				
Running time	150 s (90 s)		150 s (95 to 2000 s)				
Fail-safe mode	---			35 s	30 s		
Fail-safe function	---					indirect	direct
Nominal force	800 N						1600 N
Travel	2 to 20 mm						
Enclosure	IP 54						
Process medium max. temperature	+5 ... 150°C						
Ambient temperature range	0 to 50°C						
Ambient humidity limit	5 ... 95 %						
Weight	1,5 kg						

### Multi-functional technology MFT

Due to a built-in microprocessor, some of the actuator's parameters can be set by the user, e.g.: type of control signal, running time, tripping torque value, etc. The configuration is carried out with PC or a special programming device.

### Dimensions of actuator

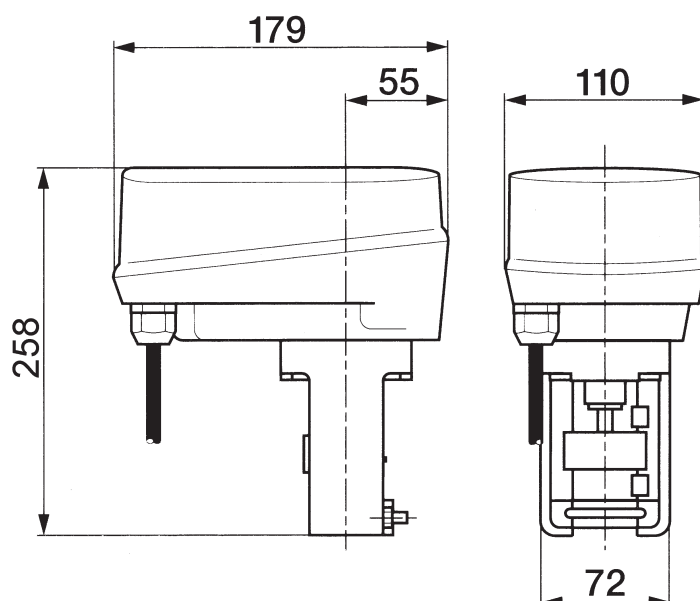

## Wiring diagram of actuators

NV24-3 a NV230-3

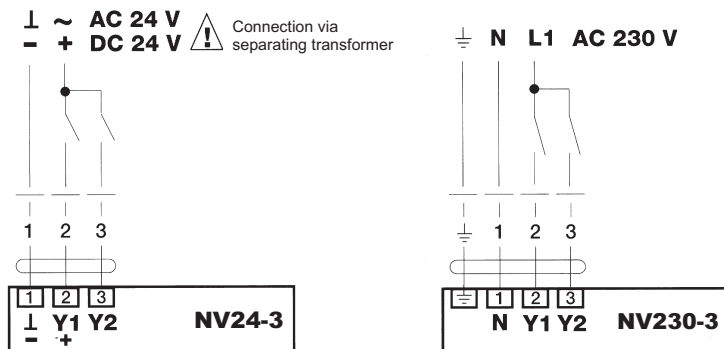

NV24-MFT a NVY24-MFT

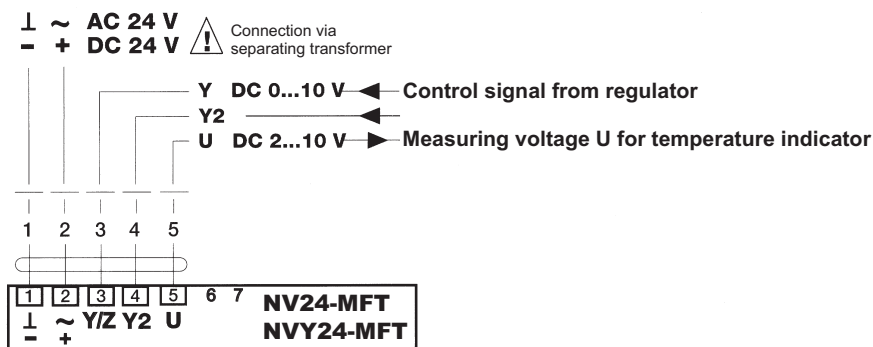

NVF24-MFT a NVF24-MFT-E

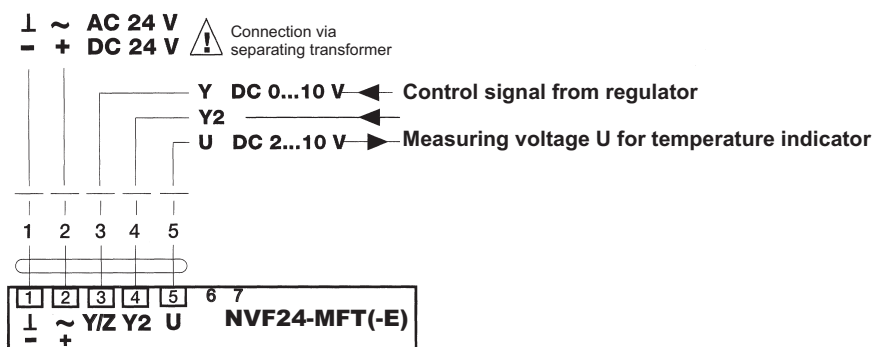

NVG24-MFT

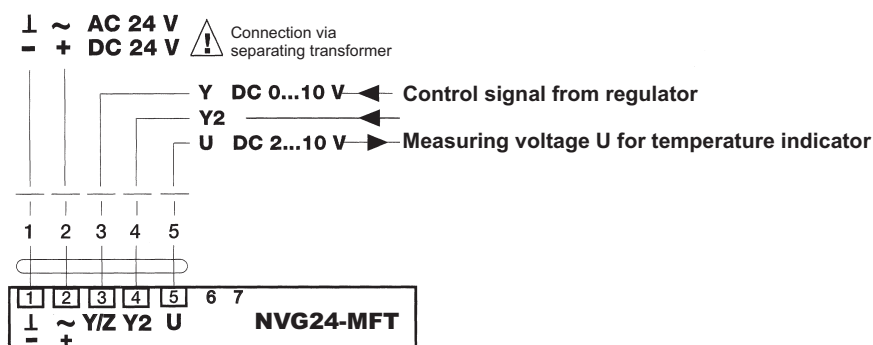



## Electric actuators AV... Belimo

### Technical data

Type	AV24-3-R	AV230-3-R	AV24-MFT-R	AVY24-MFT-R
Voltage	AC/DC 24 V	AC 230 V	AC/DC 24 V	
Frequency	50...60 Hz			
Motor power / Sizing	4 W / 5 VA	4 W / 5,5 VA	6 W / 10 VA	
Control	3 - position		0 - 10 V (3 - position, ON - OFF)	
Running time	300 s (150 s)		150 s	60 s
Nominal force	2000 N			
Travel	8 to 50 mm			
Enclosure	IP 54			
Process medium max. temperature	+5 ... 150°C			
Ambient temperature range	0 to 50°C			
Ambient humidity limit	5 ... 95 %			
Weight	3,5 kg			

### Multi-functional technology MFT

Due to a built-in microprocessor, some of the actuator's parameters can be set by the user, e.g.: type of control signal, running time, tripping torque value, etc. The configuration is carried out with PC or a special programming device.

### Dimensions of actuator

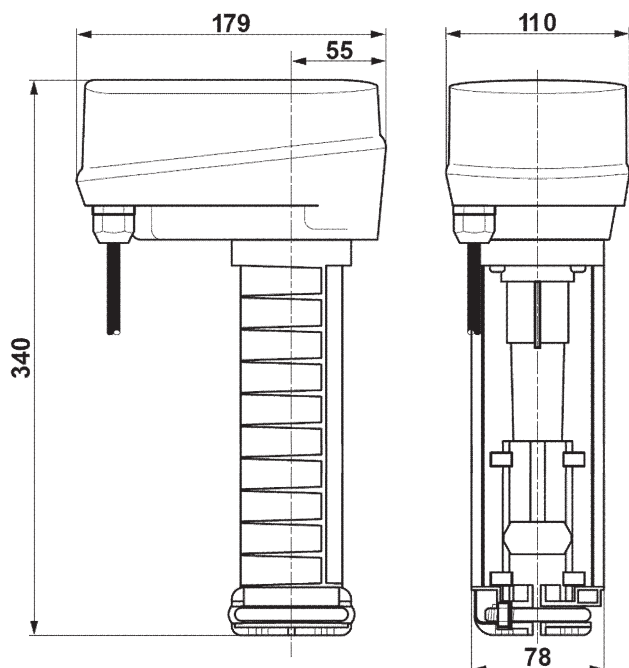

## Wiring diagram of actuators

AV24-3-R a AV230-3-R

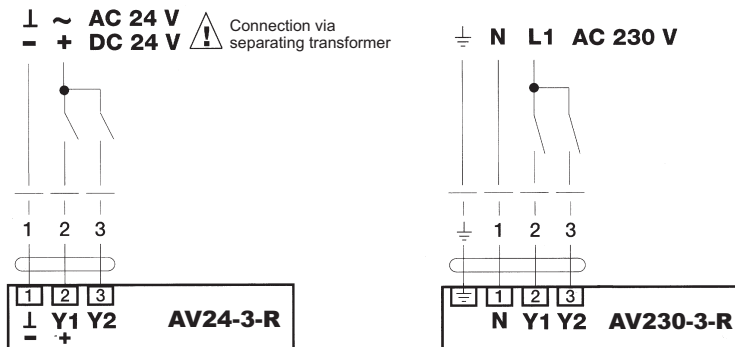

AV24-MFT-R a AVY24-MFT-R

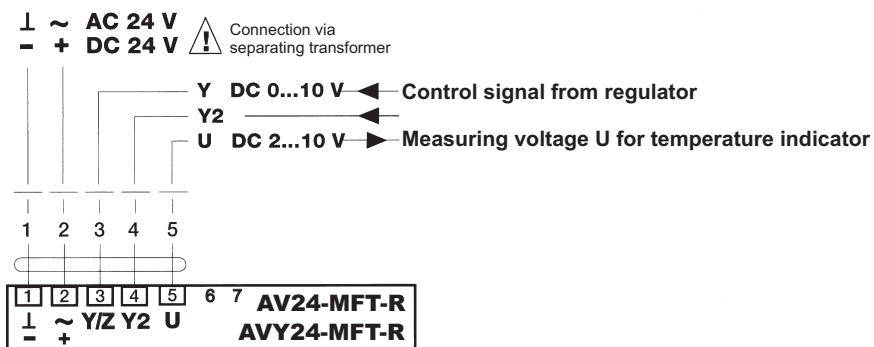



## Electric actuators PTN 2 Ekorex

### Technical data

Type	PTN 2.20	PTN 2.32	PTN 2.40
Voltage	230 V + 6 %, -12 % or 24 V + 10 %, -15 % AC		
Frequency	50 Hz		
Power consumption	Max. 19 VA		
Control	3 - position control, (0) 4 - 20 mA, 0 - 10 V		
Nominal force	2000 N	3200 N	4000 N
Travel	20 and 40 mm		
Enclosure	IP 65		
Process medium max. temperature	Acc. to used valve		
Ambient temperature range	-20 to 60°C		
Ambient humidity range	5 to 100 % with condensation		
Weight	4 kg		

### Wiring diagram of actuator

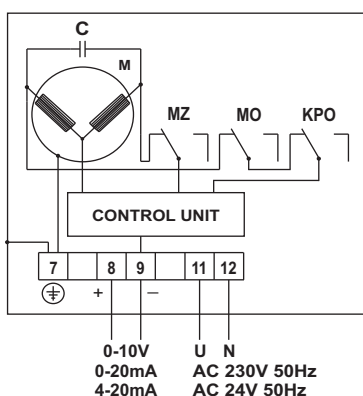
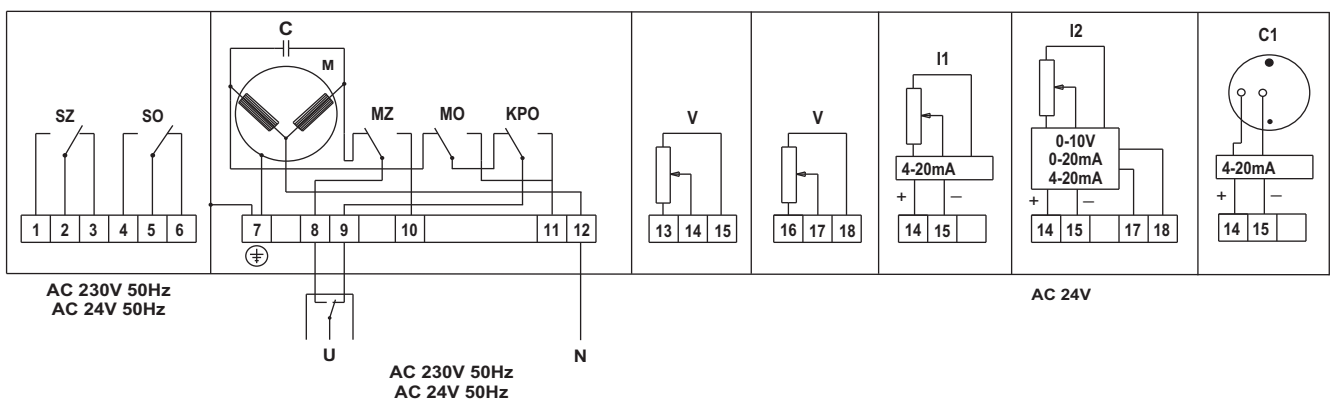

- MO - power switch for "OPEN" position
- MZ - power switch for "CLOSED" position
- SO - signalisation switch for "OPEN" position
- SZ - signalisation switch for "CLOSED" position
- KPO - terminal position switch for "OPEN" position
- M - motor
- C - capacitor
- V - resistance transmitter 100 Ω
- I1 - resistance transmitter with convertor 4-20 mA - 2-wire execution
- I2 - resistance transmitter with convertor - separate feeding 24V AC

## Specification of actuator PTN 2

PTN 2	X	X	X	X	X	X	X	X	Nominal force [kN]	Resetting speed [ mm/min <sup>-1</sup> ]
	2	0							2	10, 16, 25, 32
	3	2							3,2	10, 16, 25, 32
	4	0							4	10, 16, 25
			0						230 V, 50 Hz	Motor supply voltage
			2						24 V, 50 Hz	
				1					10	Resetting speed [mm.min <sup>-1</sup> ]
				2					16	
				3					25	
				4					32	
				0					Without equipment	Independent feeding 24 V
				1					Output 0 - 10 V	
				2					Output 0 - 20 mA	
				3					Output 4 - 20 mA	
				4					Output 4 - 20 mA	
				5					Output 0 - 100 Ω 1x	
				6					Output 0 - 100 Ω 2x	
				7					Feedback - Capacity transmitter 4 - 20 mA	2 - wire connection
				7				Flange D44	stem notch D7	
				8				Flange D44	stem notch D10	stroke 40 mm
				0					MO; MZ	Number of microswitches
				2					MO; MZ; SO; SZ	
				9					According to agreement	
				4				20	Draw bar stroke [mm]	
				7				40		

### NOTE:

The table applies to actuator with 3-position control.

It is possible to supply actuator with control signal of 0 - 10 V, 0 - 20 mA, 4 - 20 mA and with manual operating outside the housing.

(example of marking: PTN 2 - XX.XX.XX.XX / control signal 4 - 20 mA)

## Dimensions of actuator PTN 2

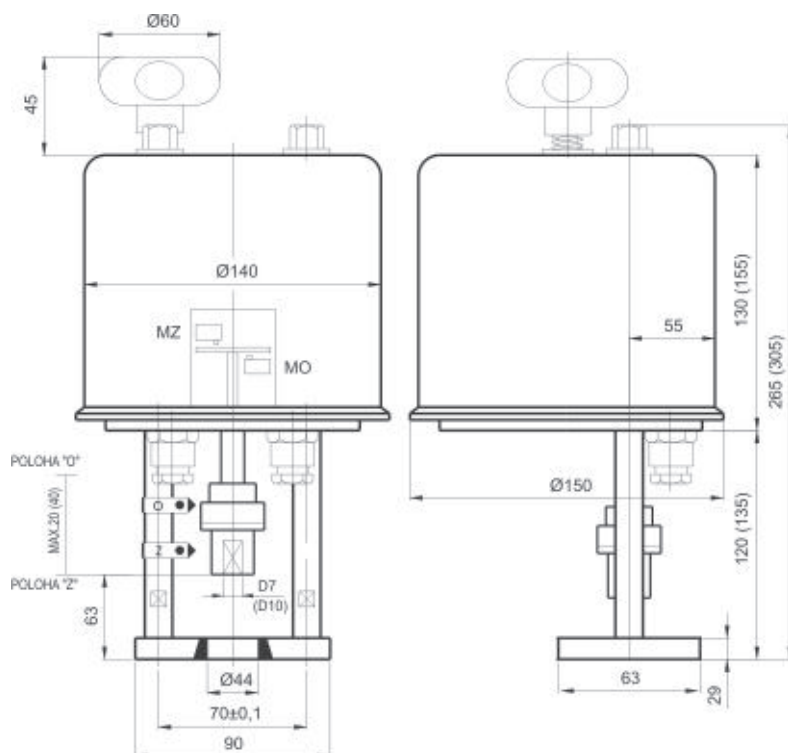



## Electric actuators ANT40.11 LDM

### Description

The actuators are designed for regulators with continuous or contact output. They are suitable to actuate two-way and three-way valves series RV 113 and RV 2xx. The actuator consists of cover made of self-extinguishing plastic housing a stepping motor, control unit with SUT technology, signalisation LEDs and no-maintenance gear made of sintered steel. The connection to its valve is provided by stainless steel columns and yoke made of light metal alloy. Electric connection (max. 2,5 mm<sup>2</sup>) is provided with the aid of screw clamps. There are three self-breaking openings for cable glands M20x1,5 (2x) and M16x1,5. One cable gland M20x1,5 is a part of standard delivery.

### Application

Based on a connection variant (see wiring diagram), the actuator can be used as floating (0...10 V or 4...20 mA), or 2-position (open-closed) or 3-position (open-stop-closed). Manual operating is available with outer handle. The motor is disconnected when the hand crank is folded back. When the handle is positioned back, the actuator resumes into required position (without initialization). If the hand crank remains folded out, the actuator keeps its set position.

### Technical data

Type	ANT40.11	
Specification code	EVH	
Execution	Electric actuator with SUT technology	
Voltage	24 V AC, 24 V DC	230 V AC
Frequency	50 Hz	
Power consumption	18 VA	
Control	0 - 10 V, 4 - 20 mA, 3-pos., 2-pos.	3-position
Open-close running time	Adjustable 2, 4, 6 s.mm <sup>-1</sup>	
Nominal force	2500 N	
Travel	20 a 40 mm	
Enclosure	IP 65	
Process medium max. temperature	200°C, with a mid piece up to 240°C	
Ambient temperature range	-10 to 55°C	
Ambient humidity range	< 95 % relative humidity	
Weight	4,5 kg	

### Installation position

Upright, vertical, max. horizontal.

### SUT Technology

The actuator can be controlled by regulators with continuous (0...10 V and/or 4...20 mA) or contact (2-position or 3-position) output. The actuator feeding is optional. The running speed and output characteristic is also optional.

### Features

- electronic switch off based on the running force registered by stops inside appliance or valve.
- automatic adapting to the valve stroke
- code switch for characteristic and running time selection
- hand crank for manual operating with swithing the motor off as a start for new initiation
- possibility of direction change of control signal (feeding voltage at terminal 2a or 2b)



## Accessories

0313529 001	Split range unit to set sequences
0372332 001	Module, plug-in type, for 230 V ± 15% voltage supply and 3-point activation, additional power 2 VA
0372333 001	2 auxiliary changeover switches, continuously adjustable, additional load 5(2) A, 12 - 250 V, 3(1) A, 12 - 250 V AC <sup>1)</sup>
0372333 002	2 auxiliary changeover contacts with gold-plated contacts for low currents from 1 mA, max. 30 V, 3(1) A, 12 - 250 V AC <sup>1)</sup>
0372334 001	Potentiometer 2000 Ω, 1 W, 24 V <sup>1)</sup>
0372334 002	Potentiometer 130 Ω, 1 W, 24 V <sup>1)</sup>
0372334 006	Potentiometer 1000 Ω, 1 W, 24 V <sup>1)</sup>
0372336 910	Mid piece (required for medium above 200 up to 240°C)
0386263 001	Screwed cable gland M16 x 1,5
0386263 002	Screwed cable gland M20 x 1,5 (1 piece of cable gland is standard part of actuator delivery)

<sup>1)</sup>one option of accessory can be used only

## Operation

### Initialisation and feedback signal

When used as a continuous drive, the device initialises itself automatically. As soon as voltage is applied to the drive for the first time, it moves to the lower limit stop on the valve, thus enabling automatic connection with the valve spindle. Then it moves to the upper limit stop and the value is recorded and saved with the help of a path measurement system. The control signal and the feedback signal are adjusted to this effective stroke. There is no re-initialisation if the voltage is interrupted or if the voltage supply is removed. The values remain saved.

To re-initialise, the drive must be connected to the voltage. To trigger an initialisation, fold the hand crank out and back in again twice within 4 seconds. Both the LEDs will then flash red. During initialisation, the feedback signal is inactive, or it corresponds to a value of "0". Initialisation uses the shortest run time. The re-initialisation is only valid once the entire procedure has been completed. Folding the hand crank out again will interrupt the procedure.

If the valve drive detects a blockage, it will report this by setting the feedback signal to 0 V after approx. 90 s. However, the drive will try to overcome the blockage during this time. If it is possible to overcome the blockage, the normal control function is activated again and the feedback signal is resumed.

No initialisation is performed with a 2-position or 3-position control. The feedback signal is inactive.

### Connection as a 2-position valve drive (24 V)

This activation (OPEN/CLOSED) can take place via two cables. The voltage is applied to terminals 1 and 2a. Applying the voltage (24 V) to terminal 2b opens the valve's control passage. After this voltage has been switched off, the drive moves to the opposite end position and closes the valve. The electronic motor switch-off responds in the end positions (valve limit stop, or when maximum stroke is reached) or in case of overload (no limit switches).

The coding switch can be used to set the run times. The characteristic curve cannot be selected in this case (resulting in the characteristic curve for the valve). Terminals 3i, 3u and 44 must not be connected.

### Connection as a 3-position valve drive (24 V)

Applying voltage to terminal 2a (or 2b) makes it possible to move the valve to any desired position. If voltage is applied to terminals 1 and 2b, the valve shaft moves out and opens the valve. It moves in and closes the valve when the electrical circuit is closed over terminals 1 and 2a.

In the end positions (at the valve stop, or when the maximum stroke is reached) or in case of an overload, the electronic motor switch-off responds (no limit switches). The direction of the stroke can be changed by transposing the connections.

The coding switch is used to set the run times. In this case, the characteristic curve cannot be selected (resulting in the characteristic curve for the valve). Terminals 3i, 3u and 44 must not be connected.

### Connection as a 3-position valve drive with 230 V

The accessory module is plugged on in the connection area and is then connected for 3-position mode. If this accessory is used, only control in 3-position mode is available. The coding switch on the baseboard can be used to select the run times. The characteristic curve cannot be selected; the characteristic curve for the valve is applicable.

The module has a built-in switch which is automatically moved into the correct position when the module is installed. On this drive (which has no spring return action) the switching lever is in the lower position.

The accessory module is not suitable for 2-position activation.

### Connection to a control voltage (0...10 V and/or 4...20 mA)

The built-in positioner controls the drive depending on the controller output signal y.

The control signal used is a voltage signal (0...10 V<sup>-</sup>) at terminal 3u, or a current signal at terminal 3i. If a control signal is present at both terminals (3u (0...10 V) and 3i (4...20 mA)) simultaneously, the input with the higher value takes priority.

**Mode of action 1** (mains voltage to internal connection 2a): as the output signal increases, the valve shaft moves out and opens the valve (control passage).

**Mode of action 2** (mains voltage to internal connection 2b): as the output signal increases, the valve shaft moves in and closes the valve (control passage).

The starting point and the control span are fixed. To set partial ranges (and only for voltage input 3u), a split range unit is available as an accessory (see the split range unit function); this unit is intended for installation in the drive.

After the voltage supply is applied and after initialisation, the drive moves to each valve stroke between 0% and 100%, depending on the control signal. The electronics and the path measurement system ensure that no stroke is lost, and the drive does not require re-initialisation at intervals. When the end positions are reached, the position is checked, corrected as necessary and stored again. This ensures parallel running of several drives of the same SUT type. Feedback signal y0 = 0...10 V corresponds to the effective valve stroke of 0 to 100%. If the 0...10 V control signal is interrupted in direction of action 1, the spindle retracts completely and the valve is closed. So that the valve can be opened (direction of action 1), a voltage

of 10 V must be connected between terminals 1 and 3u, or it is necessary to switch over to direction of action 2.  
The coding switch can be used to set the characteristic for the valve. Equal-percentage and square characteristics can only

be produced if the device is used as a continuous-action drive. Further switches can be used to select the run-times (can be used for the 2-position, 3-position or continuous functions).

## LED display

Both LEDs flashing red: initialisation procedure
Upper LED lit red: upper limit stop or "CLOSED" position reached
Lower LED lit red: lower limit stop or "OPEN" position reached
Upper LED flashing green: drive running, moving towards "CLOSED" position
Upper LED lit green: drive stationary, last direction of running "CLOSED"
Lower LED flashing green: drive running, moving towards "OPEN" position
Lower LED lit green: drive stationary, last direction of running "OPEN"
Both LEDs are lit green: waiting time after switching on, or after emergency function
No LED lit: no voltage supply (terminal 2a or 2b)
Both LEDs are flashing red and green: drive is in manual mode

## Accessories application

### Split range unit

This accessory can be built into the drive or can be accommodated externally in an electrical distribution box. The starting point  $U_0$  and the control span  $\Delta U$  can be set with the help of a potentiometer. This makes it possible to operate several regulating units in sequence or in a cascade with the control signal from the controller. The input signal (partial range) is converted into an output signal of 0...10 V.

### Auxiliary changeover switch

Auxiliary changeover switch double 0372333 001

- Switching capacity max. 250 V~, min. current 250 mA at 12 V (or 20 mA at 20 V)
- Switching capacity max. 12...30 V=, max. current 100 mA

Auxiliary changeover switch double gold 0372333 002

- Switching capacity max. 250 V~, min. current 1 mA at 5 V
- Switching capacity max. 0.1...30 V=, current 1...100 mA

Even if used only once above 10 mA or up to 50 V, the gold coating will be destroyed. The switch can then be used only for higher switching outputs.

## Engineering and installation notes

Penetration of condensate or dripping water, etc. along the valve spindle into the drive should be avoided.

The valve is plugged directly onto the drive and is fixed with screws (no further settings are needed). The drive is automatically connected to the valve spindle. When the device is delivered, the drive spindle is in the middle position.

The housing contains three breakthrough-type cable leadthroughs which are broken open automatically when the cable leadthrough is screwed in. The stepping motor/electronics concept guarantees parallel running of several valve drives of the same type. The cross-section of the connecting cable should be selected according to the line length and the number of drives. With five drives connected in parallel and a line length of 50 m, we recommend using a cable cross-section of 1.5 mm<sup>2</sup> (power consumption of the drive × 5). The drive can be assembled with a maximum of one 230 V module, one additional accessory component (auxiliary switch or potentiometer) and the split range unit.

### Warnings

If the temperature of the medium in the valve is high, the drive columns and the shaft may also reach high temperatures. It is necessary to ensure that the maximum ambient temperature be max. 55°C during operation. If the temperature exceeds this limit, it is recommended to insulate the valve (eg. IKA insulation, see catalogue sheet 01-09.6).

If a failure of the final control element could cause damage, additional protective precautions must be taken.

## CE - Conformity

EMV Directive 89/336/EWG	Machinery Directive 98/37/EWG/II/B	Low Voltage Directive 73/23/EWG
EN 61000-6-1	EN 1050	EN 60730 1
EN 61000-6-2		EN 60730-2-14
EN 61000-6-3		Over-voltage category III
EN 61000-6-4		Degree of pollution III

## Switch coding

**Actuator characteristic (switches 3 and 4)**  
- optional for actuators with floating control only

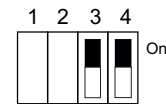
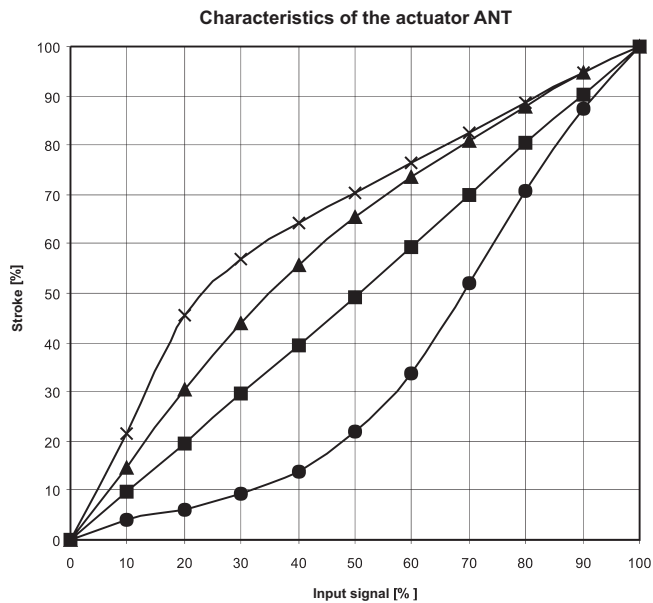

**A (Linear)**



**B (Quadratic)**



**C (Logarithmic)**



**D (Equal percentage)**

**Run time (switches 1 and 2)**  
- optional for all types of control of the actuator

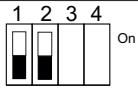
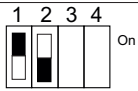
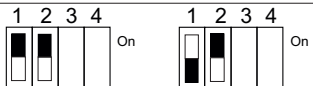
Run time per mm	Switch coding	Run time for 20 mm stroke	Run time for 40 mm stroke
2 s / mm		40 s ± 1	80 s ± 2
4 s / mm		80 s ± 2	160 s ± 4
<b>6 s / mm</b>		<b>120 s ± 4</b>	<b>240 s ± 8</b>

Note: Data in bold mean factory settings

## Dimensions of actuator and a mid piece for higher temperatures

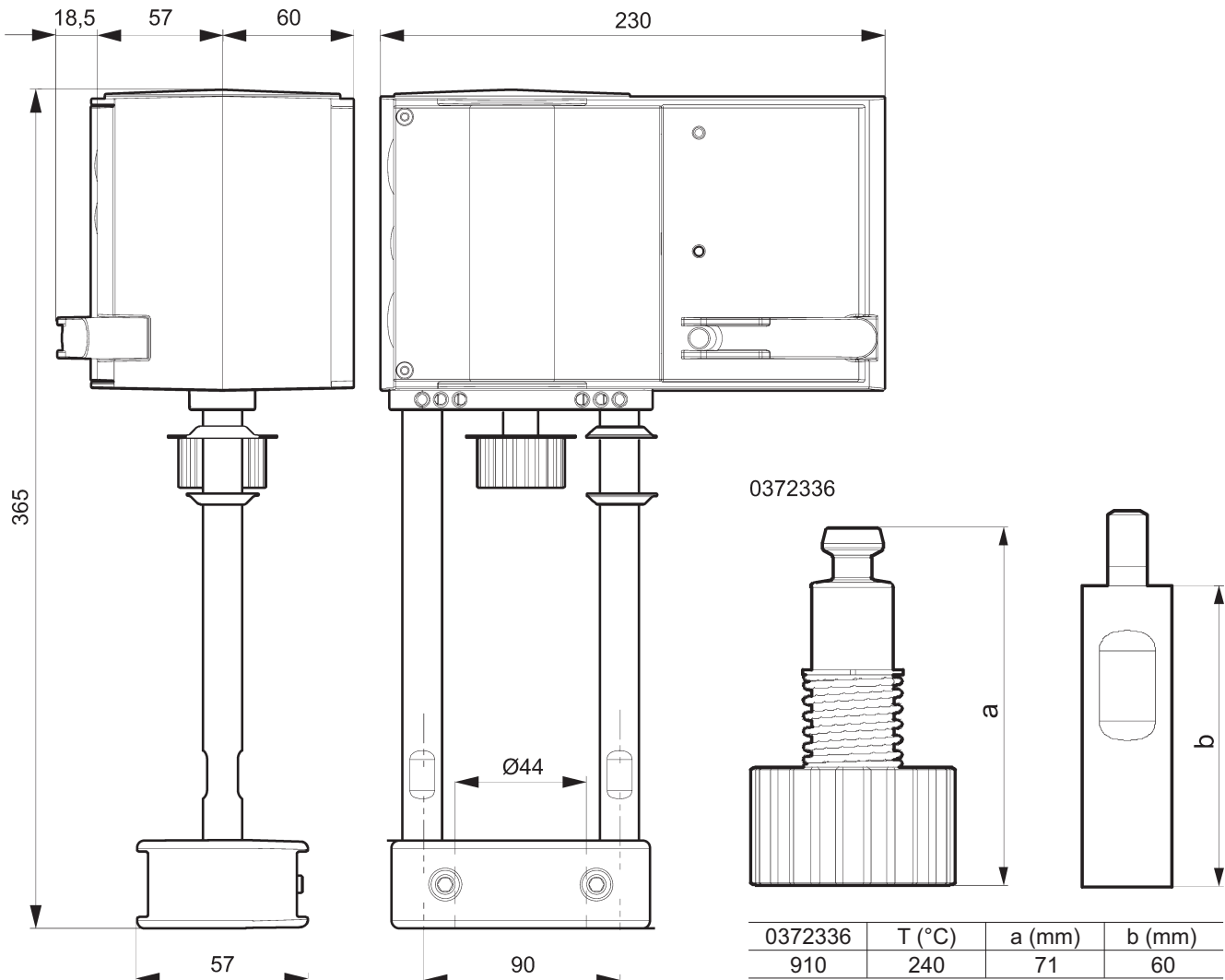

## Wiring diagram of actuators

ANT 40.11

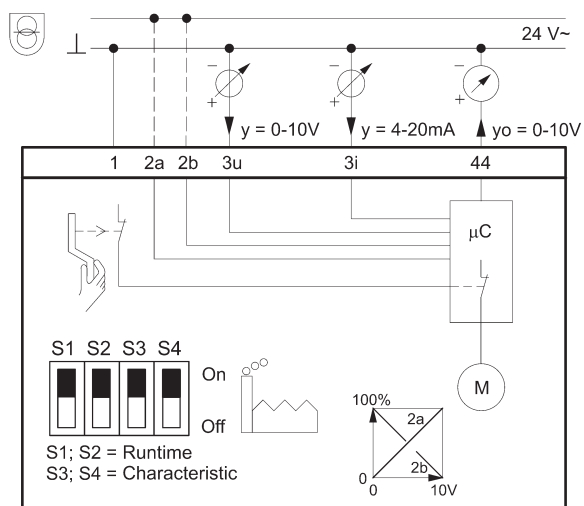

Variant 1 (3-pos. control)

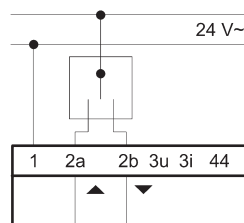

Variant 2 (2-pos. control)

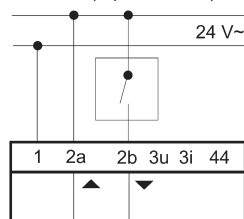

A10357

## Wiring diagram of accessories

313529

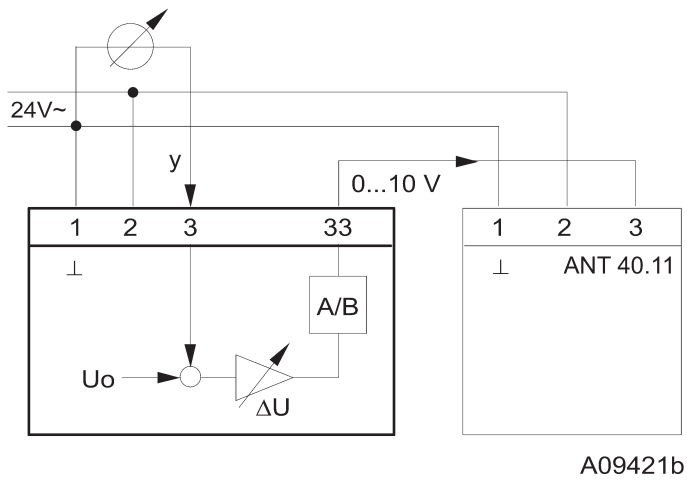

372332

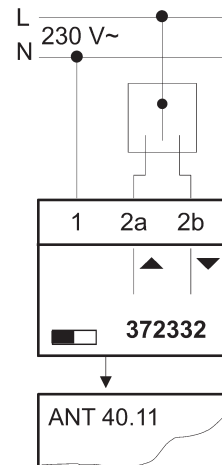

372333

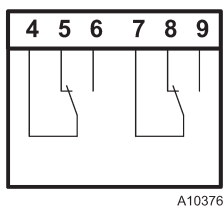

372334

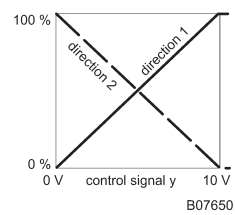
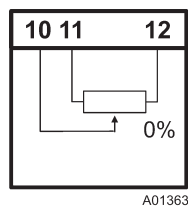



## Electric actuators ANT40.11S ANT40.11R LDM

### Description

The actuator is designed for regulators with continuous or contact output. They are suitable for actuating two-way or three way valves series RV 113 and RV 2xx. The actuator is equipped with a spring ensuring the actuator runs into its defined end position in case of power supply failure or when the sensor of limit value is activated. The actuator consists of a cover made of self-extinguishing plastic housing stepping motor, control unit with SUT technology, signalisation LEDs and no-maintenance gear made of sintered steel and spring roll. The connection to its valve is provided by stainless steel columns and yoke made of light metal alloy. Electric connection (max. 2,5 mm<sup>2</sup>) is provided with the aid of screw clamps. There are three self-breaking openings for cable glands M20x1,5 (2x) and M16x1,5. One cable gland M20x1,5 is a part of standard delivery.

### Application

Based on a connection variant (see wiring diagram), the actuator can be used as floating (0...10 V or 4...20 mA), or 2-position (open-closed) or 3-position (open-stop-closed). Manual operating is with outer hand crank. The motor is disconnected when the hand crank is folded out. When the hand crank is folded back, the actuator resumes into required position (without initialization). If the hand crank remains folded out, the actuator keeps its set position.

### Installation position

Upright, vertical, max. horizontal.

### Technical data

Type	ANT40.11S		ANT40.11R	
Specification code	EVI			
Execution	Electric actuator with spring return action and SUT technology			
Voltage	24 V AC, 24 V DC	230 V	24 V AC, 24 V DC	230 V
Frequency	50 Hz			
Power consumption	20 VA in operation mode, 7 VA out of operation			
Control	0-10 V, 4-20 mA, 3-pos., 2-pos.	3-position	0-10 V, 4-20 mA, 3-pos., 2-pos.	3-position
Open-close running time	Adjustable 2, 4, 6 s.mm <sup>-1</sup>			
Running time for fail-safe function	Acc. to stroke 15 - 30 s			
Fail-safe function	Indirect (NC)		Direct (NO)	
Nominal force	2000 N			
Stroke	20 a 40 mm			
Enclosure	IP 66			
Process medium max. temperature	200°C, with a mid piece up to 240°C			
Ambient temperature range	-10 to 55°C			
Ambient humidity range	< 95 % relative humidity			
Weight	6,1 kg			

### SUT Technology

The actuator can be controlled by regulators with continuous (0...10 V and/or 4...20 mA) or contact (2-position or 3-position) output. The actuator feeding is optional. The running speed and output characteristic is also optional.

### Features

- electronic switch off based on the running force registered by stops inside appliance or valve.
- automatic adapting to the valve stroke
- code switch for characteristic and running time selection
- hand crank for manual operating with swithing the motor off as a start for new initiation
- possibility of direction change of control signal (feeding voltage at terminal 2a or 2b)

### Direct and indirect function of actuator

Direct function ensures that actuator stem extends (the valve opens) upon power supply failure.

Indirect function ensures that actuator stem retracts (the valve closes) upon power supply failure.

## Accessories

0313529 001	Split range unit to set sequences
0372332 001	Module, plug-in type, for 230 V $\pm$ 15% voltage supply and 3-point activation, additional power 2 VA
0372333 001	2 auxiliary changeover switches, continuously adjustable, additional load 5(2) A, 12 - 250 V, 3(1) A, 12 - 250 V AC <sup>1)</sup>
0372333 002	2 auxiliary changeover contacts with gold-plated contacts for low currents from 1 mA, max. 30 V, 3(1) A, 12 - 250 V AC <sup>1)</sup>
0372334 001	Potentiometer 2000 $\Omega$ , 1 W, 24 V <sup>1)</sup>
0372334 002	Potentiometer 130 $\Omega$ , 1 W, 24 V <sup>1)</sup>
0372334 006	Potentiometer 1000 $\Omega$ , 1 W, 24 V <sup>1)</sup>
0372336 910	Intermediate piece (required for medium above 200 up to 240°C)
0386263 001	Screwed cable gland M16 x 1,5
0386263 002	Screwed cable gland M20 x 1,5 (1 piece of cable gland is standard part of actuator delivery)

<sup>1)</sup>one option of accessory can be used only

## Operation

After a new start, or after a start following activation of the reset (terminal 21), up to 45 s of waiting time will pass before the drive is available again. Depending on the type of connection (see the wiring dia-gram), the device can be used as a continuous-action drive (0...10 V and/or 4...20 mA), a 2-point drive (open-closed) or a 3-position drive (open-stop-closed).

### Initialisation and feedback signal

The drive initialises itself automatically, whether it is used in continuous-action, 2-position or 3-position mode. As soon as voltage is applied to the drive for the first time and the waiting period has elapsed, the drive moves to the lower limit stop on the valve, thus enabling automatic connection with the valve spindle. Then it moves to the upper limit stop, and the value is recorded and saved with the help of a path measurement system. The control signal and the feedback signal are adjusted to this effective stroke. After an interruption to the voltage or a spring return action, no re-initialisation is performed and the values are saved.

To re-initialise, the drive must be connected to the voltage. To trigger an initialisation, fold the hand crank out and back in again twice within 4 seconds. Both the LEDs will then flash red. During initialisation, the feedback signal is inactive, or it corresponds to a value of "0". Initialisation uses the shortest run time. The re-initialisation is only valid once the entire procedure has been completed. Folding the hand crank out again will interrupt the procedure.

If the valve drive detects a blockage, it will report this by setting the feedback signal to 0 V after approx. 90 s. However, the drive will try to overcome the blockage during this time. If it is possible to overcome the blockage, the normal control function is activated again and the feedback signal is resumed.

### Spring return

If the voltage supply fails or is switched off, or if a monitoring contact responds, the brushless DC mo-tor releases the gear and the drive is moved into the respective end position (depending on the design version) by the pre-tensioned spring. As this happens, the control function of the drive is disabled for 45 s (both LEDs flash green) so that the end position can be reached in every case. The reset speed is controlled with the help of the motor so that there are no pressure surges in the line. The brushless DC motor has three functions: as a magnet to hold the position, as a brake (by acting as a generator) and as a motor for the control function. After a spring return function, the drive does not re-initialise itself.

### Connection as a 2-position valve drive (24 V)

This activation (OPEN/CLOSED) can take place via two cables. The voltage is applied to terminals 1 2a and 21. Applying the voltage (24 V) to terminal 2b causes the coupling rod to extend and opens the valve. After this voltage has been switched off, the drive moves to the opposite end position and closes the valve. The electronic motor switch-off responds in the end positions (valve limit stop, or when maximum stroke is reached) or in case of overload (no limit switches).

The coding switch can be used to set the run times. The characteristic curve cannot be selected in this case (resulting in the characteristic curve for the valve). The feedback signal is active as long as the initialisation is performed and there is voltage present at terminal 21. Terminals 3i, 3u and 44 must not be connected.

### Connection as a 3-position valve drive (24 V)

Applying voltage to terminal 2a (or 2b) makes it possible to move the valve to any desired position. If voltage is applied to terminals 1 and 2b, the valve shaft moves out and opens the valve. It moves in and closes the valve when the electrical circuit is closed over terminals 1 and 2a.

In the end positions (at the valve stop, or when the maximum stroke is reached) or in case of an overload, the electronic motor switch-off responds (no limit switches). The direction of the stroke can be changed by transposing the connections.

The coding switch is used to set the run times. In this case, the characteristic curve cannot be selected (resulting in the characteristic curve for the valve). The feedback signal is active as long as the initialisation is performed and there is voltage present at terminal 21. Terminals 3i, 3u must not be connected

### Connection as a 3-position valve drive with 230 V

The accessory module is plugged on in the connection area and is then connected for 3-position mode. If this accessory is used, only control in 3-position mode is available. The coding switch on the baseboard can be used to select the run times. The characteristic curve cannot be selected; the characteristic curve for the valve is applicable.

The module has a built-in switch which is automatically moved into the correct position when the module is installed. With this application, the switching lever is in the upper position.

The accessory module is not suitable for 2-position activation.

### Connection to a control voltage (0...10 V and/or 4...20 mA)

The built-in positioner controls the drive depending on the controller output signal y.

The control signal used is a voltage signal (0...10 V-) at



is present at both terminals (3u (0...10 V) and 3i (4...20 mA)) simultaneously, the input with the higher value takes priority.

**Mode of action 1** (mains voltage to internal connection 2a): as the output signal increases, the valve shaft moves out and opens the valve (control passage).

**Mode of action 2** (mains voltage to internal connection 2b): as the output signal increases, the valve shaft moves in and closes the valve (control passage).

The starting point and the control span are fixed. To set partial ranges (and only for voltage input 3u), a split range unit is available as an accessory (see the split range unit function); this unit is intended for installation in the drive.

After the voltage supply is applied and after initialisation, the drive moves to each valve stroke between 0% and 100%, depending on the control signal. The electronics and the path

measurement system ensure that no stroke is lost, and the drive does not require re-initialisation at intervals. When the end positions are reached, the position is checked, corrected as necessary and stored again. This ensures parallel running of several drives of the same type. Feedback signal  $y_0 = 0...10$  V corresponds to the effective valve stroke of 0 to 100%.

If the control signal 0...10 V is interrupted in mode of action 1, the spindle moves in completely and the valve is closed. So that the valve can be opened (direction of action 1), a voltage of 10 V must be connected between terminals 1 and 3u, or it is necessary to switch over to direction of action 2.

The coding switch can be used to set the characteristic curve for the valve: linear, equal percentage or quadratic. This characteristic curve can only be generated if the drive is used as a continuous drive. Additional switches can be used to select the run times (applicable for 2-position, 3-position or continuous function).

## LED display

---

Both LEDs flashing red: initialisation procedure

---

Upper LED lit red: upper limit stop or "CLOSED" position reached

---

Lower LED lit red: lower limit stop or "OPEN" position reached

---

Upper LED flashing green: drive running, moving towards "CLOSED" position

---

Upper LED lit green: drive stationary, last direction of running "CLOSED"

---

Lower LED flashing green: drive running, moving towards "OPEN" position

---

Lower LED flashing green: drive stationary, last direction of running "OPEN"

---

Both LEDs are lit green: waiting time after switching on, or after emergency function

---

No LED lit: no voltage supply (terminal 2a or 2b)

---

Both LEDs are flashing red and green: drive is in manual mode

---

## Accessories application

### Split range unit

This accessory can be built into the drive or can be accommodated externally in an electrical distribution box. The starting point  $U_0$  and the control span  $\Delta U$  can be set with the help of a potentiometer. This makes it possible to operate several regulating units in sequence or in a cascade with the control signal from the controller. The input signal (partial range) is converted into an output signal of 0...10 V.

### Auxiliary changeover switch

Auxiliary changeover switch double 0372333 001

- Switching capacity max. 250 V~, min. current 250 mA at 12 V (or 20 mA at 20 V)
- Switching capacity max. 12...30 V=, max. current 100 mA

Auxiliary changeover switch double gold 0372333 002

- Switching capacity max. 250 V~, min. current 1 mA at 5 V
- Switching capacity max. 0.1...30 V=, current 1...100 mA

Even if used only once above 10 mA or up to 50 V, the gold coating will be destroyed. The switch can then be used only for higher switching outputs.

## Engineering and installation notes

Penetration of condensate or dripping water, etc. along the valve spindle into the drive should be avoided.

The valve is plugged directly onto the drive and is fixed with screws (no further settings are needed). The drive is automatically connected to the valve spindle. When the device is delivered, the drive spindle is in the middle position.

The housing contains three breakthrough-type cable leadthroughs which are broken open automatically when the cable leadthrough is screwed in. The stepping motor/electronics concept guarantees parallel running of several valve drives of the same type. The cross-section of the connecting cable should be selected according to the line length and the number of drives. With five drives connected in parallel and a line length of 50 m, we recommend using a cable cross-section of 1.5 mm<sup>2</sup> (power consumption of the drive × 5). The drive can be assembled with a maximum of one 230 V module, one additional accessory component (auxiliary switch or potentiometer) and the split range unit.

## Warnings

If the temperature of the medium in the valve is high, the drive columns and the shaft may also reach high temperatures. It is necessary to ensure that the maximum ambient temperature be max. 55°C during operation. If the temperature exceeds this limit, it is recommended to insulate the valve (e.g. IKA insulation, see catalogue sheet 01-09.6).

If a failure of the final control element could cause damage, additional protective precautions must be taken.



## CE - Conformity

EMV Directive 89/336/EWG	Machinery Directive 98/37/EWG/II/B	Low Voltage Directive 73/23/EWG
EN 61000-6-1	EN 1050	EN 60730 1
EN 61000-6-2		EN 60730-2-14
EN 61000-6-3		Over-voltage category III
EN 61000-6-4		Degree of pollution III

## Switch coding

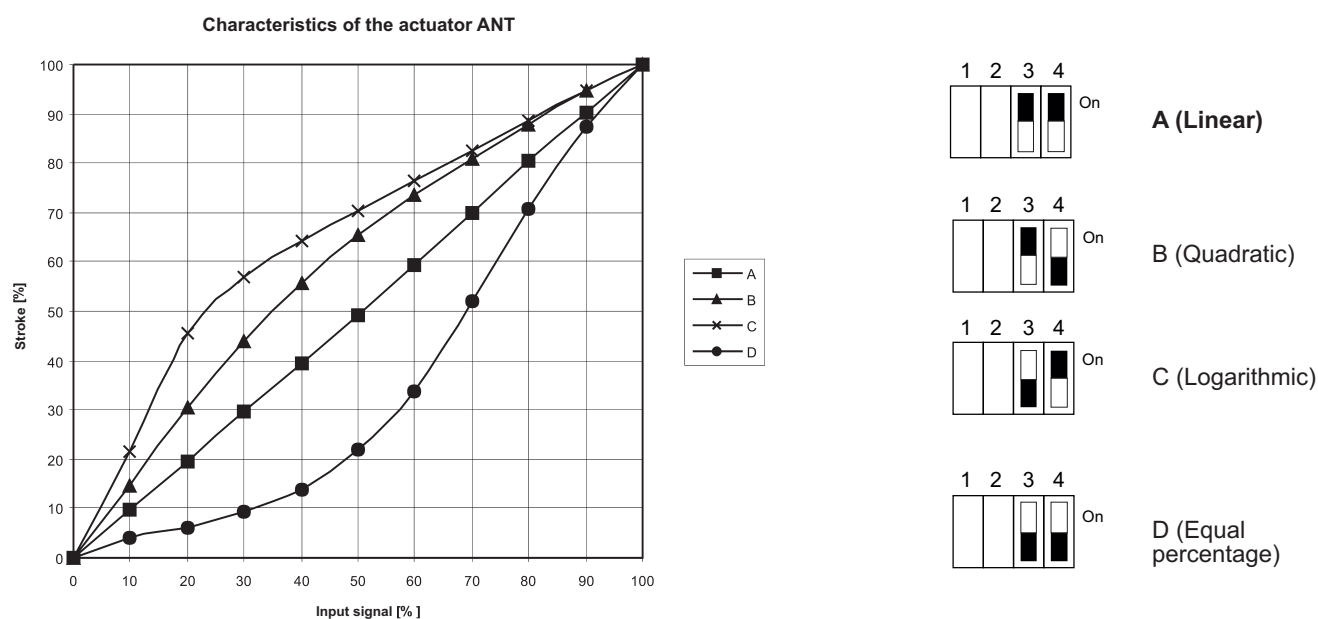

### Actuator characteristic (switches 3 and 4)

- optional for actuators with floating control only

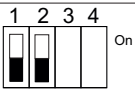
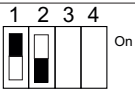

### Run time (switches 1 and 2)

- optional for all types of control of the actuator

Run time per mm	Switch coding	Run time for 20 mm stroke	Run time for 40 mm stroke
2 s / mm	<p>1 2 3 4</p> 	40 s ± 1	80 s ± 2
4 s / mm	<p>1 2 3 4</p> 	80 s ± 2	160 s ± 4
<b>6 s / mm</b>	<p>1 2 3 4</p>  <p>1 2 3 4</p> 	<b>120 s ± 4</b>	<b>240 s ± 8</b>

Note: Data in bold mean factory settings.

## Dimensions of actuator and a mid piece for higher temperatures

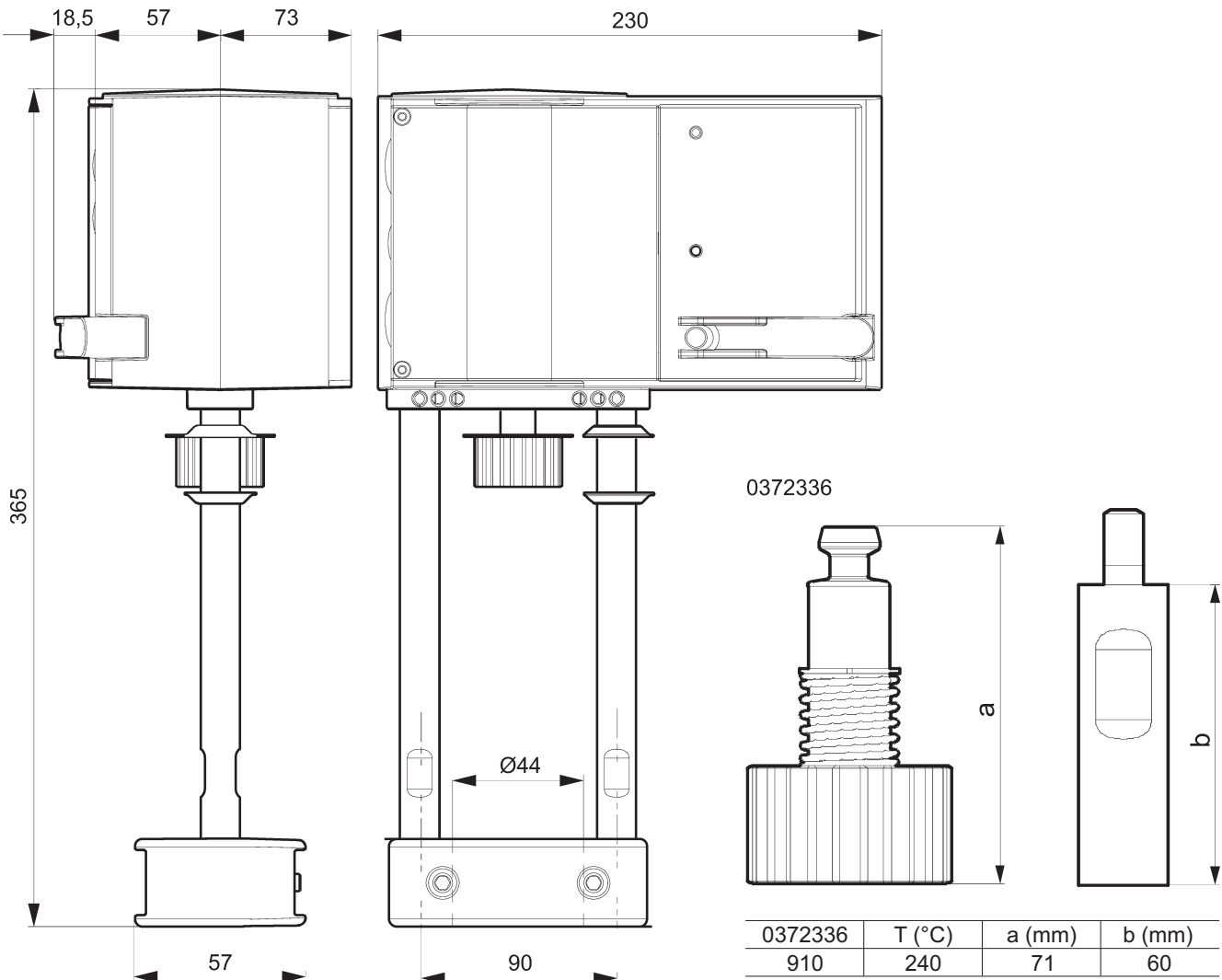

## Wiring diagram of actuators

ANT 40.11S  
ANT 40.11R

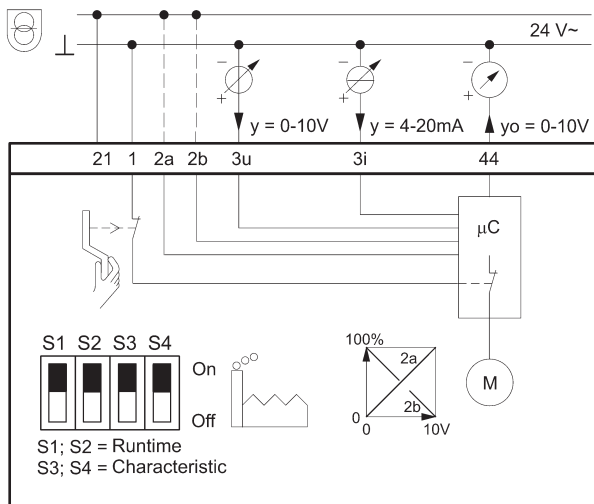

Variant 1 (3-pos. control)

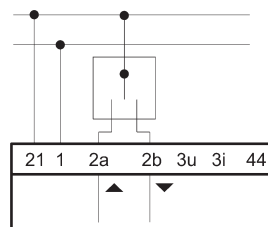

Variant 2 (2-pos. control)

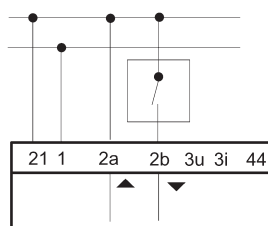

A10359

## Wiring diagram of accessories

313529

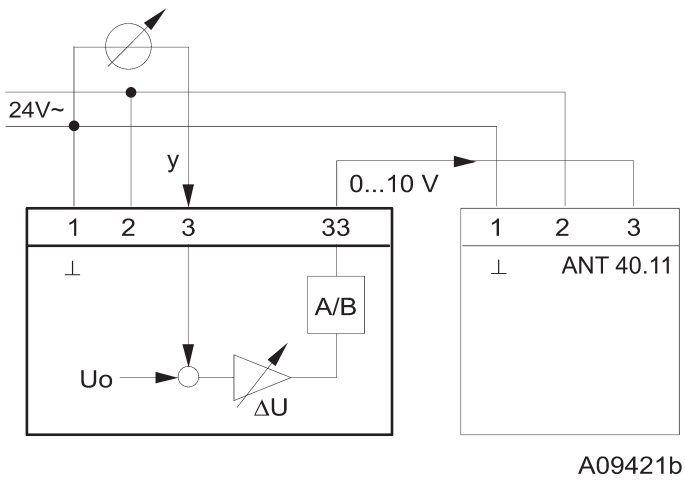

372332

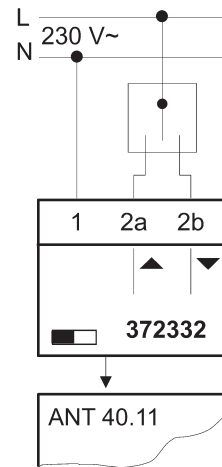

372333

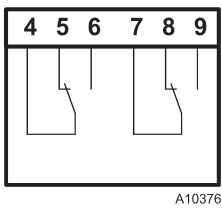

372334

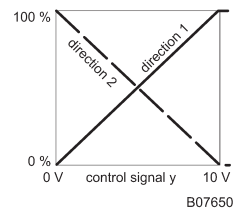
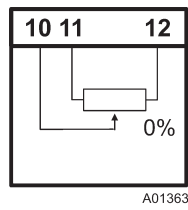



LDM, spol. s r.o.  
Litomyšlská 1378  
560 02 Česká Třebová  
Czech Republic

tel.: +420 465 502 511  
fax: +420 465 533 101  
E-mail: sale@ldm.cz  
<http://www.ldm.cz>

LDM, spol. s r.o.  
Office in Prague  
Podolská 50  
147 01 Praha 4  
Czech Republic

tel.: +420 241 087 360  
fax: +420 241 087 192

LDM, spol. s r.o.  
Office in Ústí nad Labem  
Mezní 4  
400 11 Ústí nad Labem  
Czech Republic

tel.: +420 475 650 260  
fax: +420 475 650 263

LDM servis, spol. s r.o.  
Litomyšlská 1378  
560 02 Česká Třebová  
Czech Republic

tel.: +420 465 502 411-3  
fax: +420 465 531 010  
E-mail: servis@ldm.cz

LDM, Polska Sp. z o.o.  
Modelarska 12  
40 142 Katowice  
Poland

tel.: +48 32 730 56 33  
fax: +48 32 730 52 33  
mobile: +48 601 354 999  
E-mail: ldmpolska@ldm.cz

LDM Bratislava s.r.o.  
Mierová 151  
821 05 Bratislava  
Slovakia

tel.: +421 2 43415027-8  
fax: +421 2 43415029  
E-mail: ldm@ldm.sk  
<http://www.ldm.sk>

LDM - Bulgaria - OOD  
z. k. Mladost 1  
bl. 42, floor 12, app. 57  
1784 Sofia  
Bulgaria

tel.: +359 2 9746311  
fax: +359 2 9746311  
GSM: +359 888 925 766  
E-mail: ldm.bg@ldmvalves.com

OOO "LDM Promarmatura"  
Moskovskaya street,  
h. 21, Office No. 520  
141400 Khimki  
Russian Federation

tel.: +7 495 777 22 38  
fax: +7 495 777 22 38  
E-mail: inforus@ldmvalves.com

TOO "LDM"  
Lobody 46/2  
Office No. 4  
100008 Karaganda  
Kazakhstan

tel.: +7 7212 566 936  
fax: +7 7212 566 936  
mobile: +7 701 738 36 79  
E-mail: sale@ldm.kz  
<http://www.ldm.kz>

LDM Armaturen GmbH  
Wupperweg 21  
D-51789 Lindlar  
Germany

tel.: +49 2266 440333  
fax: +49 2266 440372  
mobile: +49 177 2960469  
E-mail: ldmmaturen@ldmvalves.com  
<http://www.ldmvalves.com>

Your partner