

02 - 03.4
08.13.GB

Steam cooling unit CHP





Steam cooling unit DN 100 and higher, PN 16 - 400

Description

CHP is a body that is put directly into the steam pipeline and subsequently serves for connection with either mechanical injection head VH or drive-steam injection head VHP. According to dimensions of the pipeline and necessary intensity of cooling, the body can be equipped with more inlets for connection of VH or VHP.

CHP is supplied with flanges or with weld ends with connection flange 2 for connection of VH or VHP (max. temperature 350°C) or DN 80 (flange 1 DN 150 and higher) and dimensions according to customers requirements.

Application

CHP serves as an in-between link into the steam pipeline into which it is possible to install injection head VH, VHP. It is designed especially for industrial applications such as low-pressure steam production in heating or the steam production for technological processes.

Process media

Application of CHP for other process media than water, water vapour, should be selected in respect to the kind of process medium that is in touch with the material of CHP and should be consulted with the producer.

Installation

It is necessary to keep free space above connection flange (flange 2) for possible installation of injection head VH or VHP. CHP can be piped horizontally, vertically or inclined.

Technical data

Series	CHP	
Execution	Flanged or weld ends	
Nominal diameter range	Flange 1 - DN 100 and higher; flange 2 - DN 50 and 80 **)	
Nominal pressure	PN 16 - 400	
Material of pipe	Cast steel 1.0425	Alloy steel 1.7335
Material of flanges	Cast steel 1.0425 / 1.0426	Alloy steel 1.7335
Process medium temperature range	-20 to 400°C (350°C) *)	-20 to 550°C
Connection dimensions (flange 1 / weld ends)	Acc. to ČSN EN 1092-1 + A1 (7/2013) / ČSN EN 12627 (8/2000) **)	
Connection flange 2 dimensions	Acc. to ČSN EN 1092-1 + A1 (7/2013)	

*) Execution with connection flange 2 DN 50 up to 350°C maximum.

***) Dimensions and type of connection (flange / weld connection) acc. to customer requirements. It shall be specified in order.

Connection dimensions

Flange 1		Flange 2												V	L	
PN	DN	DN	PN 100, 160			PN 250			PN 320			PN 400				
			D ₁	D ₂	d	D ₁	D ₂	d	D ₁	D ₂	d	D ₁	D ₂	d	mm	mm
			mm	mm	mm	mm	mm	mm	mm	mm	mm	mm	mm	mm		
16 to 400	min. 100 ^{***})	50 [*])	195	145	26	200	150	26	210	160	26	235	180	30	***)	***)
		80 ^{**})	230	180	26	250	200	30	275	220	30	305	240	33		

- *) Execution with connection flange 2 DN 50 t_{max} 350 °C.
 **) Execution with connection flange 2 DN 80 only with flange 1 DN 150 and higher
 ***) Dimensions and type of connection (flange / weld connection) acc. to customer requirements. It shall be specified in order.

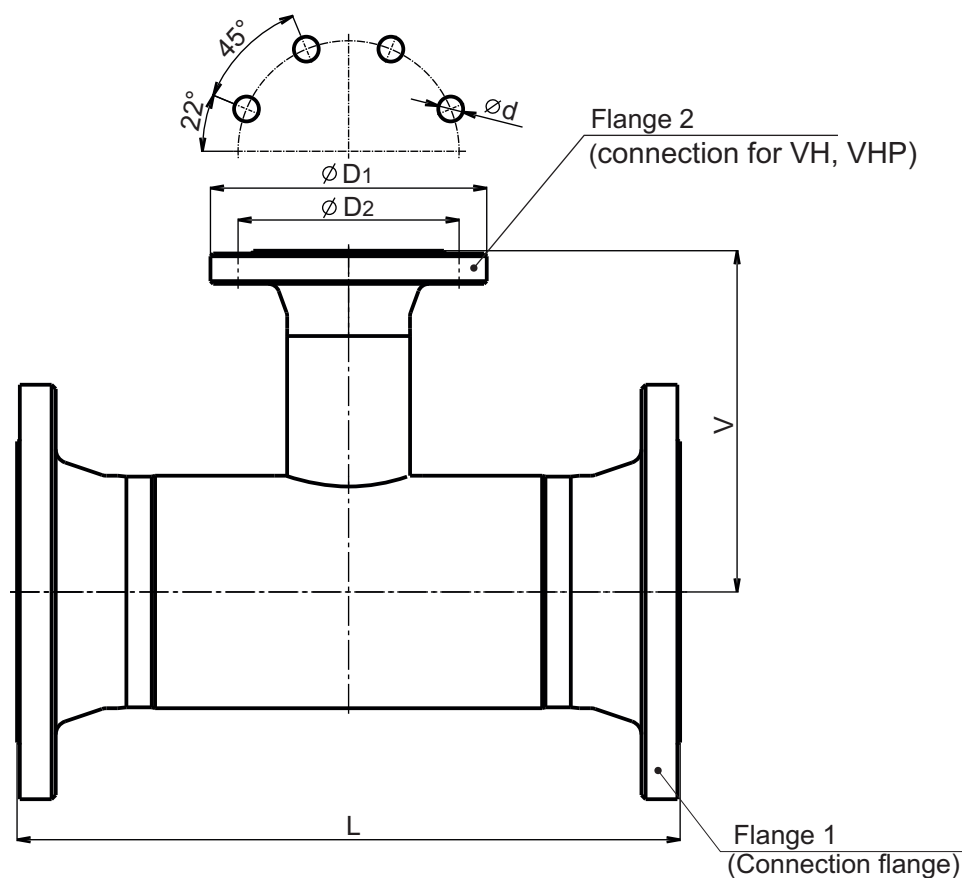

Valve complete specification No. for ordering CHP

		XXX	X	XXX	/	XXX	-	XXX	X
1. Series	Steam cooling unit	CHP							
2. No. of inlets	Acc. to intensity of cooling		X						
3. Nominal diameter	Flange 1 - steam pipeline			XXX					
	Flange 2 - connection of VH, VHP					050			
						080			
4. Nominal pressure	PN 25							XXX	
5. Body material	Cast steel 1.0425 (-20 to 400°C)								1
	Alloy steel 1.7335 (-20 to 550°C)								2
	Other material on request								9

Order example: Steam cooling unit, steam pipeline flange DN 150, PN 40, connection flange DN 80, PN 100, body material 1.0425 is marked as follows: **CHP1 150/080-040 1**

Maximal permissible pressures [MPa]

Material	PN	Temperature [°C]									
		100	150	200	250	300	350	400	450	500	550
Cast steel 1.0425	16	1.36	1.27	1.14	1.04	0.94	0.88	0.84	---	---	---
	25	2.13	1.98	1.78	1.62	1.47	1.37	1.32	---	---	---
	40	3.41	3.17	2.84	2.60	2.35	2.19	2.11	---	---	---
	63	5.37	4.99	4.48	4.09	3.71	3.45	3.33	---	---	---
	100	8.53	7.92	7.11	6.50	5.89	5.48	5.28	---	---	---
	160	13.6	12.7	11.4	10.4	9.40	8.80	8.40	---	---	---
	250	21.3	19.8	17.8	16.2	14.7	13.7	13.2	---	---	---
	320	27.2	25.4	22.8	20.8	18.8	17.6	16.8	---	---	---
	400	34.1	31.7	28.4	26.0	23.5	21.9	21.1	---	---	---
Alloy steel 1.7335	16	1.63	1.58	1.49	1.43	1.33	1.23	1.15	1.07	0.89	0.35
	25	2.54	2.48	2.33	2.23	2.08	1.93	1.80	1.67	1.39	0.55
	40	4.07	3.96	3.74	3.57	3.33	3.09	2.89	2.67	2.23	0.88
	63	6.41	6.24	5.88	5.63	5.24	4.86	4.55	4.20	3.51	1.39
	100	10.17	9.90	9.34	8.93	8.32	7.71	7.22	6.67	5.57	2.21
	160	16.3	15.8	14.9	14.3	13.3	12.3	11.5	10.7	8.90	3.50
	250	25.4	24.8	23.3	22.3	20.8	19.3	18.0	16.7	13.9	5.50
	320	32.6	31.6	29.8	28.6	26.6	24.6	23.0	21.4	17.8	7.00
	400	40.7	39.6	37.4	35.7	33.3	30.9	28.9	26.7	22.3	8.80



LDM, spol. s r.o.
Litomyšlská 1378
560 02 Česká Třebová
Czech Republic

tel.: +420 465 502 511
fax: +420 465 533 101
E-mail: sale@ldm.cz
<http://www.ldm.cz>

LDM, spol. s r.o.
Office in Prague
Podolská 50
147 01 Praha 4
Czech Republic

tel.: +420 241 087 360
fax: +420 241 087 192

LDM, spol. s r.o.
Office in Ústí nad Labem
Mezní 4.
400 11 Ústí nad Labem
Czech Republic

tel.: +420 475 650 260
fax: +420 475 650 263

LDM servis, spol. s r.o.
Litomyšlská 1378
560 02 Česká Třebová
Czech Republic

tel.: +420 465 502 411-3
fax: +420 465 531 010
E-mail: servis@ldm.cz

LDM Polska Sp. z o. o.
Modelarska 12
40 142 Katowice
Polska

tel.: +48 32 730 56 33
fax: +48 32 730 52 33
mobile: +48 601 354 999
E-mail: ldmpolska@ldm.cz
<http://www.ldmpolska.pl>

LDM Bratislava s.r.o.
Mierová 151
821 05 Bratislava
Slovakia

tel.: +421 2 43415027-8
fax: +421 2 43415029
E-mail: ldm@ldm.sk
<http://www.ldm.sk>

LDM - Bulgaria - OOD
z. k. Mladost 1
bl. 42, floor 12, app. 57
1784 Sofia
Bulgaria

tel.: +359 2 9746311
fax: +359 2 9746311
GSM: +359 888 925 766
E-mail: ldm.bg@stark-net.net

OOO "LDM"
Jubilejnyj prospekt,
dom.6a, of. 602
141407 Khimki
Moscow Region
Russian Federation

tel.: +7 495 7559372
fax: +7 495 7559372
E-mail: inforus@ldmvalves.com

TOO "LDM"
Lobody 46/2
Office No. 4
100008 Karaganda
Kazakhstan

tel.: +7 7212 566 936
fax: +7 7212 566 936
mobile: +7 701 738 36 79
E-mail: sale@ldm.kz
<http://www.ldm.kz>

LDM Armaturen GmbH
Wupperweg 21
D-51789 Lindlar
Germany

tel.: +49 2266 440333
fax: +49 2266 440372
mobile: +49 177 2960469
E-mail: ldmarmaturen@ldmvalves.com
<http://www.ldmvalves.com>

Your partner