

01 - 09.5

04.14.GB

**Strainers - flanged
FP 110, FP 210, FP 220, FP 230**



FP 110
FP 210
FP 220
FP 230



Strainers - flanged
DN 15 - 400, PN 16, 25, 40

Description

Flanged strainers FP 110, 210, 220, 230 are designed to clean process media from mechanical impurities. The strainers excel with a robust body construction made of stainless steel with possibility of draining without necessity of bonnet dismantling.

Application

The strainers are designed for applications in heating and other industries especially in hot-water, possibly steam circuits. The wide range of diametres enables using of these strainers in most of the common applications.

Process media

The strainers are suitable for water, steam, air and other neutral media compatible with material of body and screen.

Installation

Flow direction is determined by the arrows on the body. General mounting position of the strainer in a horizontal pipeline is by the bonnet downwards.

In a vertical pipeline is allowed top-down flow direction only. When used for water steam or gases, preferable mounting position is to avoid floatation (i. e. bonnet sideward).

Technical data

Series	FP 110	FP 210	FP 220	FP 230
Execution	Strainer - flanged			
Diameter nominal range	DN 15 to 400	DN 15 to 200	DN 15 to 200	
Nominal pressure	PN 16	PN 25	PN 16, 25, 40	
Material of body and bonnet	Grey cast iron EN-JL1040 (EN-GJL-250)	Spheroidal cast iron EN-JS1050 (EN-GJS-500-7)	Cast steel 1.0619 (GP240GH)	Stainless steel 1.4581 (GX5CrNiMonb19-11-2)
Mesh screen material	Stainless steel 1.4301			
Range of operating temp.	0 to +300°C	-10 to +350°C	-20 to +400°C	
Connection	Type B1 (raised-faced flange) acc. to ČSN EN 1092-2 (1/1999)		Type B1 (raised-faced flange) acc. to ČSN EN 1092-1+A1 (7/2013)	
Face to face dimensions	Face to face dimensions acc. to ČSN EN 558+A1, section 1 (5/2012)			

Kvs values and loss coefficient ζ (zeta)

	DN															
	15	20	25	32	40	50	65	80	100	125	150	200	250	300	350	400
Kvs [m³/h]	5.7	10.4	16.4	27.3	42	64.7	96	149	223	347	480	853	1104	1450	1800	2200
ζ	2.5	2.4	2.3	2.3	2.3	2.4	3.1	3.0	3.2	3.2	3.5	3.5	5.1	6.2	7.4	8.5

Mesh size table

Row "A" is a mesh screen standard execution		DN															
		15	20	25	32	40	50	65	80	100	125	150	200	250	300	350	400
A	Marking	FS45				FS28				FS15							
	Size	Ø 1,0 mm				Ø 1,25 mm				Ø 1,6 mm							
B	Marking	FS100															
	Size	Ø 0,6 mm															
C	Marking	FS200															
	Size	Ø 0,5 mm															
D	Marking	FS300															
	Size	Ø 0,4 mm															
E	Marking	FS400															
	Size	Ø 0,32 mm															
F	Marking	FS600															
	Size	Ø 0,25 mm															
G	Marking	FS1.0								FS1.6				FS3.1			
	Size	Ø 1,0 mm								Ø 1,6 mm				Ø 3,1 mm			

Specification code for ordering the strainers series FP

		XX	XXX	X	XX	XX	/	XXX	-	XXX
1. Strainer	Strainer - flanged	FP								
2. Series	Strainer made of grey cast iron EN-JL1040		110							
	Strainer made of spheroidal cast iron EN-JS1050		210							
	Strainer made of cast steel 1.0619		220							
	Strainer made of stainless steel 1.4581		230							
3. Execution	Stainless screen			S						
	Stainless screen with magnetic insertion			M						
4. Mesh size	A to G (according to the Mesh size table)				X					
5. Body material	Grey cast iron EN-JL1040					3				
	Spheroidal cast iron EN-JS1050					4				
	Cast steel 1.0619					1				
	Stainless steel 1.4581					8				
	Other material after agreement					9				
6. Nominal pressure	PN 16							16		
	PN 25							25		
	PN 40							40		
7. Max. operating temp. °C	300°C								300	
	350°C								350	
	400°C								400	
8. Nominal diameter	DN 15 to 400	DN								XXX

Order example : **FP210 SA4 25/250-065**

Dimensions and weights for the strainers series FP

DN	PN 16				PN 25				PN 40				PN 16, 25, 40				PN16,25	PN 40	PN 16	PN 25	PN 40												
	Dz	Dp	Do	n	d	g	Dz	Dp	Do	n	d	g	Dz	Dp	Do	n	d	g	L	B	C	H ₁	H	H	m	m	m						
	mm	mm	mm		mm	mm	mm	mm	mm		mm	mm	mm	mm	mm		mm	mm	mm	mm	mm	mm	mm	mm	kg	kg	kg						
15	95	46	65	4	14	14	95	46	65	4	14	14	95	45	65	4	14	16	130	56	23	135	90	70	2,6	2,6	2,7						
20	105	56	75			16	105	56	75			16	105	58	75			18	150	68	28	150	100	80	3	3	3,6						
25	115	65	85			16	115	65	85			16	115	68	85			18	160	82	36	180	115	88	4,3	4,3	4,5						
32	140	76	100			18	140	76	100			18	140	78	100			18	180	98	42	215	135	100	6,8	6,8	6,3						
40	150	84	110	8	19	18	150	84	110	8	23	19	150	88	110	8	22	18	200	114	50	240	150	125	8,8	9	8,7						
50	165	99	125			20	165	99	125			19	165	102	125			20	230	119	61,5	250	160	140	11	10,7	11						
65	185	118	145			20	185	118	145			19	185	122	145			22	290	134	78,5	285	180	170	16,8	16,1	15						
80	200	132	160			22	200	132	160			19	200	138	160			24	310	149	89,5	330	215	190	19,5	18,2	22						
100	220	156	180	12	23	24	235	156	190	12	28	19	235	162	190	12	30	24	350	169	109,5	365	235	225	34	32,5	31,5						
125	250	184	210			26	270	184	220			19	270	188	220			26	400	199	137,5	425	280	260	42,5	39,2	46						
150	285	211	240			26	300	211	250			20	300	218	250			28	480	224	160	480	320	320	56	52,2	71						
200	340	266	295			30	360	274	310			22	375	285	320			34	600	284	210	610	405	420	110	103	135						
250	405	319	355	16	31	32	---	---	---	16	38	---	---	---	---	16	34	---	730	434	258	915	540	---	165	---	---						
300	460	370	410			32	---	---	---			---	---	---	---			---	---	---	---	---	---	850	555	308	1110	680	---	285	---	---	
350	520	429	470			36	---	---	---			---	---	---	---			---	---	---	---	---	---	---	980	640	365	1200	755	---	373	---	---
400	580	480	525			38	---	---	---			---	---	---	---			---	---	---	---	---	---	---	---	---	---	---	---	---	---	---	---

Max. permissible pressure values [MPa]

Materiál	PN	Temperature [°C]						
		120	150	200	250	300	350	400
Grey cast iron EN-JL1040 (EN-GJL-250)	16	1,60	1,44	1,28	1,12	0,96	---	---
Spher. cast iron EN-JS1050 (EN-GJS-500-7)	25	2,50	2,38	2,25	2,00	1,75	1,38	---
Cast steel 1.0619 (GP240GH)	16	1,32	1,27	1,14	1,04	0,94	0,88	0,84
	25	2,07	1,98	1,78	1,62	1,47	1,37	1,32
	40	3,31	3,17	2,84	2,60	2,35	2,19	2,11
Stainless steel 1.4581 (GX5CrNiMoNb19-11-2)	16	1,39	1,33	1,25	1,17	1,10	1,06	1,02
	25	2,18	2,08	1,95	1,84	1,72	1,66	1,60
	40	3,49	3,33	3,13	2,94	2,75	2,65	2,56

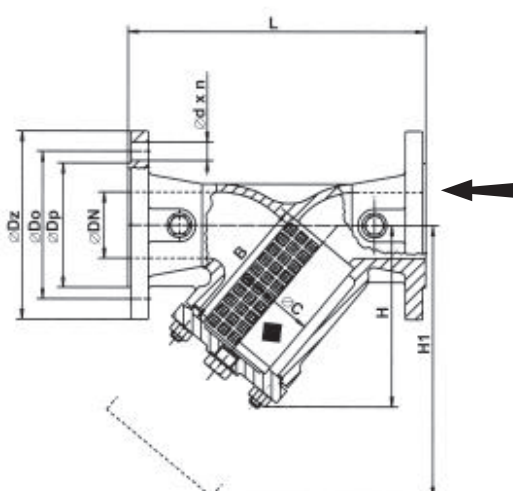



LDM, spol. s r.o.
Litomyšlská 1378
560 02 Česká Třebová
Czech Republic

tel.: +420 465 502 511
fax: +420 465 533 101
E-mail: sale@ldm.cz
<http://www.ldm.cz>

LDM, spol. s r.o.
Office in Prague
Podolská 50
147 01 Praha 4
Czech Republic

tel.: +420 241 087 360
fax: +420 241 087 192

LDM, spol. s r.o.
Office in Ústí nad Labem
Mezní 4
400 11 Ústí nad Labem
Czech Republic

tel.: +420 475 650 260
fax: +420 475 650 263

LDM servis, spol. s r.o.
Litomyšlská 1378
560 02 Česká Třebová
Czech Republic

tel.: +420 465 502 411-3
fax: +420 465 531 010
E-mail: servis@ldm.cz

LDM, Polska Sp. z o.o.
Modelarska 12
40 142 Katowice
Poland

tel.: +48 32 730 56 33
fax: +48 32 730 52 33
mobile: +48 601 354 999
E-mail: ldmpolska@ldm.cz

LDM Bratislava s.r.o.
Mierová 151
821 05 Bratislava
Slovakia

tel.: +421 2 43415027-8
fax: +421 2 43415029
E-mail: ldm@ldm.sk
<http://www.ldm.sk>

LDM - Bulgaria - OOD
z. k. Mladost 1
bl. 42, floor 12, app. 57
1784 Sofia
Bulgaria

tel.: +359 2 9746311
fax: +359 2 9746311
mobile: +359 888 925 766
E-mail: ldm.bg@ldmvalves.com

OOO "LDM Promarmatura"
Jubilejnyj prospekt,
dom.6a, of. 601
141400 Khimki Moscow Region
Russian Federation

tel.: +7 4957772238
fax: +7 4956662212
mobile: +7 9032254333
E-mail: inforus@ldmvalves.com

TOO "LDM"
Lobody 46/2
Office No. 4
100008 Karaganda
Kazakhstan

tel.: +7 7212 566 936
fax: +7 7212 566 936
mobile: +7 701 738 36 79
E-mail: sale@ldm.kz
<http://www.ldm.kz>

LDM Armaturen GmbH
Wupperweg 21
D-51789 Lindlar
Germany

tel.: +49 2266 440333
fax: +49 2266 440372
mobile: +49 177 2960469
E-mail: ldmarmaturen@ldmvalves.com
<http://www.ldmvalves.com>

Your partner